



# LIBRARIES

UNIVERSITY OF WISCONSIN-MADISON

## **Mineral land classification showing indications of iron formation in parts of Ashland County, Bayfield County, Washburn County, Sawyer County, Price County, Oneida County, Forest County, Rusk County, ...**

Hotchkiss, William Otis, 1878-1954.; Bean, E. F. (Ernest F.), 1882-; Wheelwright, Orville W.  
Madison, Wis.: The State, 1915

<https://digital.library.wisc.edu/1711.dl/LCZG2K3CDKQEC9D>

<https://creativecommons.org/publicdomain/mark/1.0/>

For information on re-use see:

<http://digital.library.wisc.edu/1711.dl/Copyright>

The libraries provide public access to a wide range of material, including online exhibits, digitized collections, archival finding aids, our catalog, online articles, and a growing range of materials in many media.

When possible, we provide rights information in catalog records, finding aids, and other metadata that accompanies collections or items. However, it is always the user's obligation to evaluate copyright and rights issues in light of their own use.

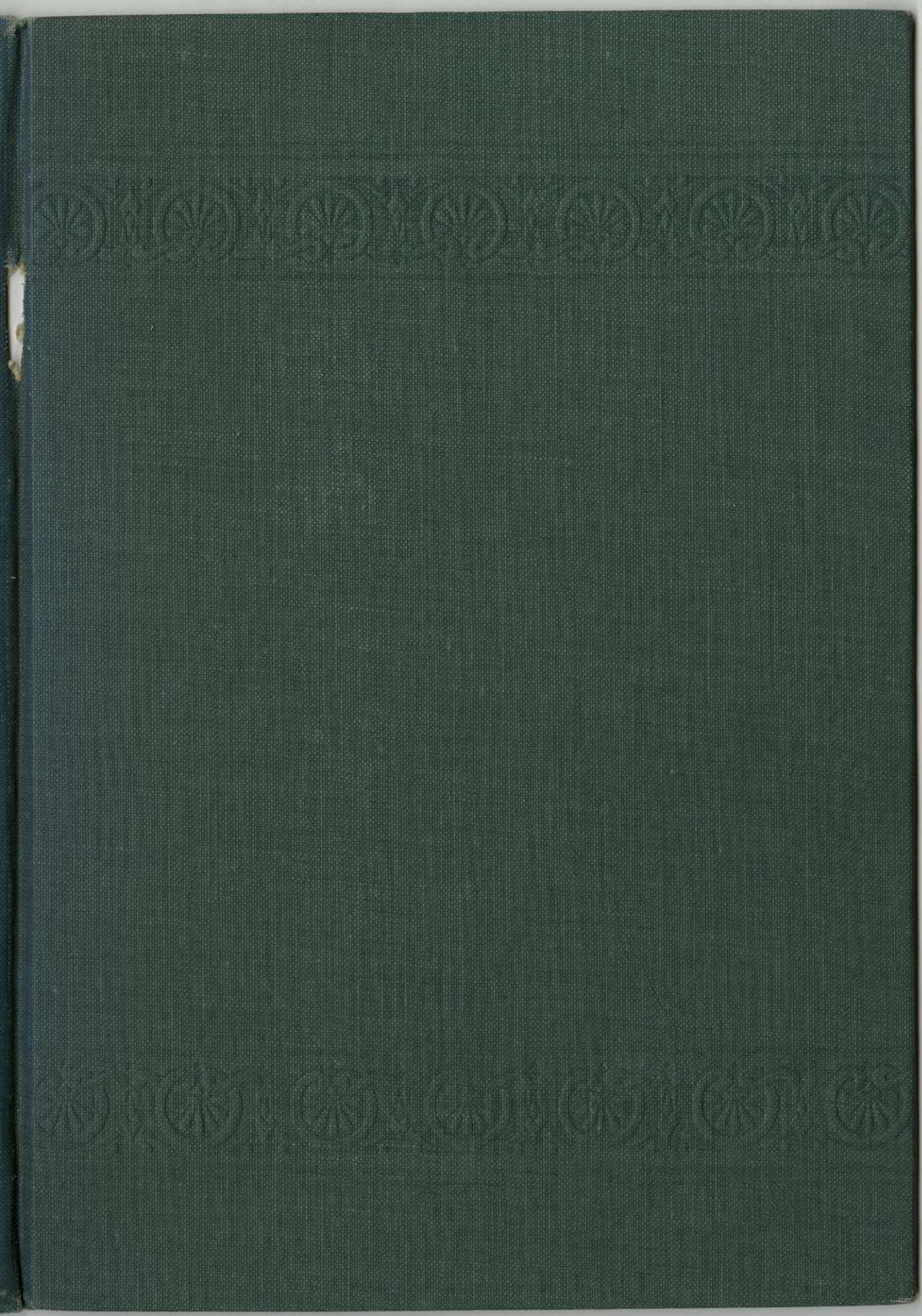

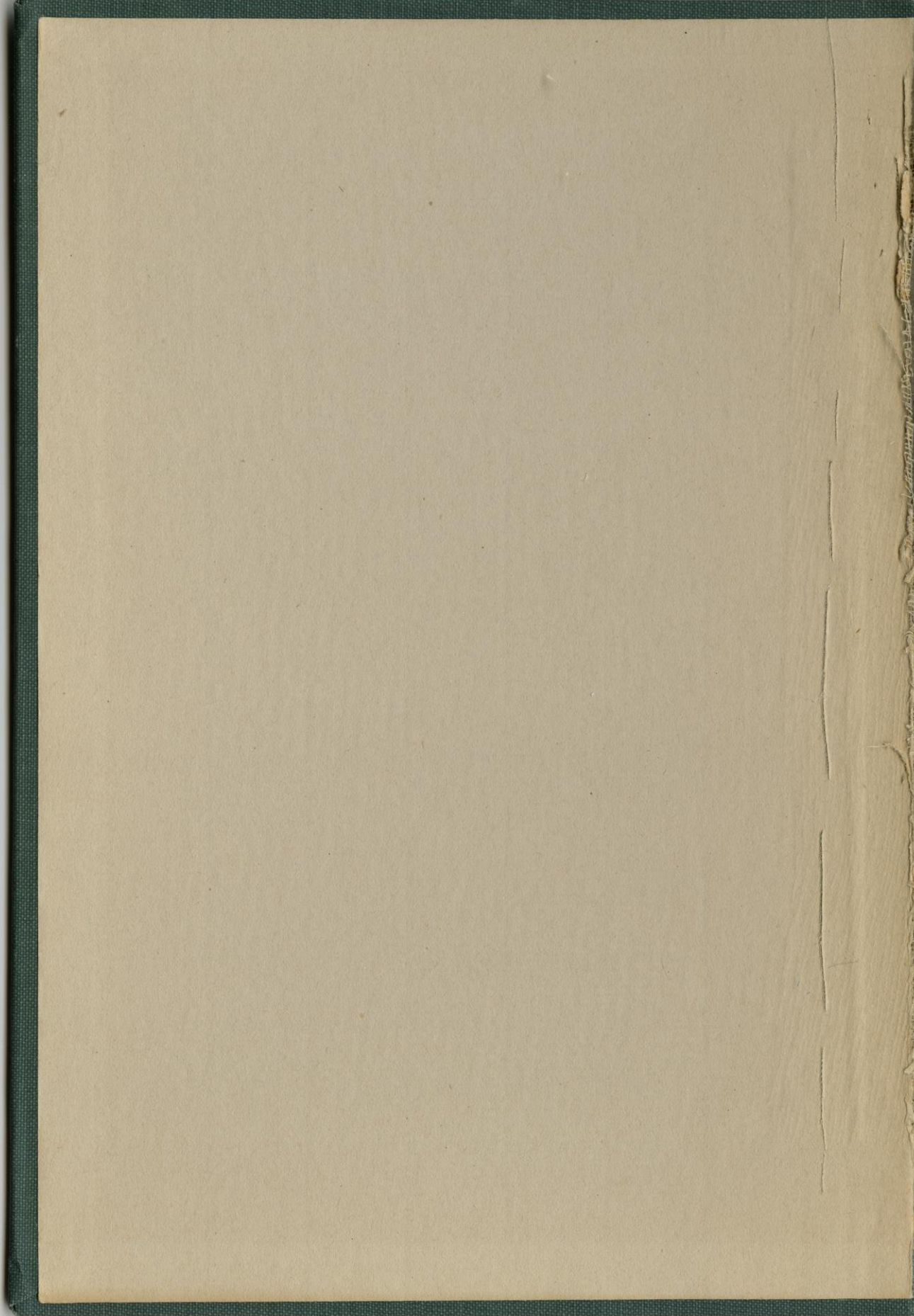

PK Series 1976



**WISCONSIN GEOLOGICAL AND NATURAL HISTORY SURVEY**

EDW. A. BIRGE, Director

WM. O. HOTCHKISS, State Geologist

---

Bulletin No. XLIV

Economic Series No. 19

---

**MINERAL LAND CLASSIFICATION**

Showing Indications of Iron Formation  
in parts of

ASHLAND, BAYFIELD, WASHBURN,  
SAWYER, PRICE, ONEIDA, FOREST, RUSK,  
BARRON AND CHIPPEWA COUNTIES

BY

W. O. HOTCHKISS

ASSISTED BY

E. F. BEAN and O. W. WHEELWRIGHT

MADISON WIS.  
PUBLISHED BY THE STATE  
1915

# Wisconsin Geological and Natural History Survey

## BOARD OF COMMISSIONERS

EMANUEL L. PHILIPP

*Governor of the State.*

CHARLES R. VAN HISE, *President*

*President of the University of Wisconsin.*

CHARLES P. CARY, *Vice-President*

*State Superintendent of Public Instruction.*

JABE ALFORD

*President of the Commissioners of Fisheries.*

HENRY L. WARD, *Secretary*

*President of the Wisconsin Academy of Sciences, Arts, and Letters.*

## STAFF OF THE SURVEY

### ADMINISTRATION:

EDWARD A. BIRGE, Director and Superintendent. In immediate charge of Natural History Division.

WILLIAM O. HOTCHKISS, State Geologist. In immediate charge of Geology Division.

LILLIAN M. VEERHUSEN, Clerk.

### GEOLOGY DIVISION:

WILLIAM O. HOTCHKISS, In charge.

T. C. CHAMBERLIN, Consulting Geologist, Pleistocene Geology.

SAMUEL WEIDMAN, Geologist, Areal Geology.

E. F. BEAN, Geologist, Chief of Field Parties.

O. W. WHEELWRIGHT, Geologist, Chief of Field Parties.

R. H. WHITBECK, Geologist, Geography of Lower Fox Valley.

LAWRENCE MARTIN, Geologist, Physical Geography.

E. STEIDTMANN, Geologist, Limestones.

F. E. WILLIAMS, Geologist, Geography and History.

### NATURAL HISTORY DIVISION:

EDWARD A. BIRGE, In charge.

CHANCEY JUDAY, Lake Survey.

H. A. SCHUETTE, Chemist.

### DIVISION OF SOILS:

A. R. WHITSON, In charge.

W. J. GEIB,\* Inspector and Editor.

GUY CONREY, Analyst.

T. J. DUNNEWALD, Field Assistant and Analyst.

CARL THOMPSON, Field Assistant and Analyst.

C. B. POST, Field Assistant and Analyst.

W. C. BOARDMAN, Field Assistant and Analyst.

\* Scientist in Soil Survey, Bureau of Soils, U. S. Department of Agriculture.

# TABLE OF CONTENTS

	Page.
ILLUSTRATIONS.....	vii
OUTLINE OF REPORT.....	ix
CHAPTER I. GENERAL INTRODUCTION.....	1
Authorization.....	1
Previous geologic work.....	1
Location.....	2
Reasons for lack of exploration for iron in Northern Wisconsin.....	2
Purpose of present work.....	4
Area covered and cost of work.....	6
Acknowledgments.....	7
CHAPTER II. METHODS OF DOING FIELD WORK.....	9
Work of geologist and compassman.....	9
Locations.....	9
Organization of field work.....	11
Instructions for field parties.....	11
General instructions.....	11
Relations to the public.....	11
Field observations.....	12
Primary purpose of survey.....	12
Note book.....	13
Topography.....	13
Culture.....	13
Magnetism.....	14
Glacial geology.....	14
General.....	14
Glacial deposits.....	14
Petrology.....	15
General.....	15
Igneous rocks.....	15
Sedimentary rocks.....	15
Soil.....	16
Timber.....	16
Symbols.....	17
Abbreviations.....	18
Special directions.....	18



CHAPTER II—continued.	Page.
Directions to Chief of Party.....	18
Notes.....	18
Tenure of jobs.....	19
Care of equipment.....	19
Accidents.....	19
Planning work.....	19
Weekly reports.....	20
Township reports.....	20
Township maps.....	21
Directions for Geological and Topographic Observations.....	22
Observations on Exposures of Glacial Drift.....	23
Observations on Topography.....	24
Hand Level Lines.....	25
Special Cautions for magnetic observations.....	25
Miscellaneous Directions and Cautions.....	26
Blazing.....	26
Photographs.....	26
Forest fires.....	26
Fire arms.....	27
 CHAPTER III. GENERAL GEOLOGY.....	 28
Introductory Statements.....	28
Geologic Formations.....	29
Sandstone.....	32
Outcrops.....	32
Topography.....	32
Character.....	33
Structure.....	34
Relations to other formations.....	35
Barron quartzite.....	35
Outcrops.....	36
Topography.....	36
Character.....	37
Structure.....	42
Thickness.....	43
Relations to other formations.....	43
Huronian formations.....	45
Distribution.....	45
Character, structure, and relations to other formations.....	49
Flambeau quartzite.....	50
Outcrops.....	50
Topography.....	50
Character.....	51
Structure.....	52
Thickness.....	52
Relations to other formations.....	52
Igneous and metamorphic rocks.....	53

TABLE OF CONTENTS.

v

CHAPTER III. GENERAL GEOLOGY—continued.	Page.
Facts which indicate the presence of an iron formation.....	54
Topography and Drainage.....	58
Analysis of Glacial Drift.....	62
CHAPTER IV. MAGNETIC OBSERVATIONS.....	75
Section I. General Principles.....	75
Local magnetic attractions.....	75
Brief general discussion of magnetic fields.....	75
A method of using components.....	80
Variations in the magnetic field of the earth.....	81
Section II. Instruments and their uses.....	85
The dial compass.....	86
Principles of the instrument.....	86
Time correction.....	86
Sources of error.....	89
Establishing the meridian.....	90
Method No. 1.....	91
Method No. 2.....	93
Compass correction table.....	94
General accuracy.....	97
The dip needle.....	97
General description.....	97
Principles of the dip needle.....	98
Determination of the relative strengths of magnetic needles...	105
Sources of error.....	105
Repairing dip needles.....	106
Method of using.....	107
Significance of magnetic observations.....	107
Character.....	110
Strike.....	110
Intensity.....	110
Dip.....	112
General conclusions.....	124
Section III. Determination of the direction and intensity of the magnetic field over magnetic formations.....	125
Instruments used and principles involved.....	126
The magnetometer.....	126
The dip circle.....	128
Standardization of instruments.....	129
The magnetometer.....	129
The dip circle.....	131
Method of taking observations.....	132
Results.....	133

	Page.
CHAPTER V. LAND CLASSIFICATION.....	137
Land classification necessarily a public function.....	137
Purposes of land classification.....	138
Principles of iron land classification.....	140
System of classification adopted.....	142
CHAPTER VI. ENPLORATION FOR IRON ORE.....	145
Definition.....	145
Elimination of barren areas.....	145
The occurrence of iron ore as related to geologic structure.....	148
Mesabi range.....	150
Gogebic range.....	151
Vermilion range.....	152
Menominee range.....	152
Marquette district.....	153
Iron river district.....	153
The Cuyuna district.....	154
The detailed examination before drilling.....	156
Methods of underground exploration.....	159
Drilling.....	159
Lands to explore in this area.....	160

## PART II.

Maps and Detailed Descriptions of Townships.....	163
Arranged with southernmost township first, and succeeding townships to the north in order with easternmost first.	

# ILLUSTRATIONS

		Facing page.
Plate	I. General map.....	10
	II. A. Compassman making traverse..... B. Reading dip needle and dial compass.....	10 10
	III. A. Geologist crossing a stream..... B. Compassman taking a sight.....	12 12
	IV. A. Railroad-cut in Barron quartzite..... B. Typical talus slope of the Barron quartzite.....	38 38
	V. A. Cliff of Barron quartzite—sandstone phase..... B. Cliff of Barron quartzite—vitreous quartzite phase.....	41 41
	Plate VI. A. Looking east over the valley of the Chippewa river..... B. Village of Morse.....	58 58
	VII. A. Pitted outwash plain..... B. Terminal moraine north-east of Glidden.....	60 60
	VIII. A. Looking south toward Flambeau Ridge..... B. A fine farm developed on outwash plain.....	62 62

## FIGURES

	Page.
Fig. 1. Areas covered by geologic surveys in the Lake Superior iron district.....	3
Fig. 2. Sketch showing the usual way in which a township was divided among the geologists.....	10
Fig. 3. Hypothetical cross-section showing the relations of the various rock formations and the reason why the outcrops are mostly granite and gneiss.....	47
Fig. 4. Lines of equal declination and equal annual change.....	76
Fig. 5. Inclination of the magnetic field to the earth's surface.....	77
Fig. 6. The effect of a magnetic substance on the field of a larger magnet.....	78
Fig. 7. A magnetic field due to the combination of the local field of a magnetic formation and the earth's field.....	79
Fig. 8. Finding the depth and position of a magnetic formation.....	81
Fig. 9. Curve showing equation of time for 1914.....	88

	Page.
Fig. 10. Diagrams illustrating methods of getting a true north-south line	92
Fig. 11. Compass correction curves showing how different compasses varied on different dates.....	96
Fig. 12. Enlarged sections showing the action of the dip needle and the effect of dust in the jewels.....	98
Fig. 13. Old and new methods of operating the clamps that hold the dip needle from swinging.....	99
Fig. 14. The two forms of dip needle.....	100
Fig. 15. Curves showing position assumed by two dip needles with different counterweights for various intensities and inclinations of the magnetic field.....	101
Fig. 16. Showing the effect upon the dip needle of changing the inclination	103
Fig. 17. The positions which the dip needle takes in going over a strongly magnetic formation.....	104
Fig. 18. Small lathe for repairing dip needle pivots.....	106
Fig. 19. Showing the effect of a magnetic formation on a dial compass needle.....	109
Fig. 20. The components of the earth's magnetic field.....	109
Fig. 21. Showing the effect of the strike of a magnetic formation on the dial compass needle.....	111
Fig. 22. Map of a magnetic line in Florence county.....	113
Fig. 23. Apparatus used in testing effect of dip and strike on the dial compass needle.....	114
Fig. 24. Dial compass curves for N-S strike with various dips and depths of burial.....	117
Fig. 25. Dial compass curves for strike N. 30° W. with various dips and depths of burial.....	118
Fig. 26. Dial compass curves for strike N. 60° W. with various dips and depths of burial.....	119
Fig. 27. Curves showing dial compass and dip needle readings for various positions of the iron sheet representing a magnetic formation	121
Fig. 28. Magnetometer diagram.....	127
Fig. 29. Illustrating relations of constants in the earth's magnetic field.....	132
Fig. 30. Magnetic observation stations on Dunkle's farm.....	133
Fig. 31. Curves showing magnetic observations on Dunkle's farm.....	135
Fig. 32. Equilibrium of dip needle.....	135
Fig. 33. Cross-section showing relation of ore, iron formation (taconite) and other rocks on the Mesabi range.....	151
Fig. 34. Gogebic range. Cross-section showing relation of ore, dikes and footwall quartzite.....	151
Fig. 35. Vermilion range. Cross-section showing occurrence of ore in various mines.....	152
Fig. 36. Menominee range. Cross-sections showing occurrence of ore.....	153
Fig. 37. Marquette range. Ideal cross-section showing various ways in which ore occurs.....	153
Fig. 38. Cuyuna range. Plan showing relation of ore bodies and iron formation to the magnetic line.....	155
Fig. 39. Block diagram showing the meaning of curves in a magnetic line....	157

## OUTLINE OF REPORT

This report covers an area in which, heretofore, no detailed geological work had been done and very little even of reconnaissance work. The area is of importance because much of it is rapidly being settled, and there is consequently demand for information as to its geologic resources. Sporadic exploration for iron ore has gone on since the seventies and the attention of persons interested in the discovery of iron ore has recently been turned with renewed force toward this great area of Pre-Cambrian rocks in northern Wisconsin.

The purpose of the report is to give as fully as possible the facts ascertainable about the area, to promote the exploration of the promising localities and to prevent the waste of money and energy in exploring in unpromising places.

Chapter I is introductory in nature and gives a general discussion of the purposes of the work, field plans, and a statement of the area covered and the expense. In Chapter II are discussed in detail the field methods and organization of the work. Chapter III takes up the general geology and gives a generalized statement of the rock formations found and their structure and relations, the details of which are discussed more fully in Part II—the township maps and descriptions. This chapter discusses in a connected manner the indications of iron formations which are given separately for each township in Part II. The general physiography of the area is also described in this chapter.

The details of magnetic surveys of the kind made in this area are given in Chapter IV with a rather full explanation of the instruments used, the interpretation of observations made with them, and their capabilities and limitations.

Chapter V outlines the basis upon which the lands were divided into classes and gives the reasons for believing that ore may be discovered here. Methods of exploration are described in Chapter VI and recommendations made as to exploration that may be carried on in this district.

Part II consists of the detailed township maps and the accompanying descriptions. Each township is fully described under the following heads:

*Surface Features.*—Topography, profiles, roads, timber and other resources.

*Glacial Drift.*—Character and thickness.

*General Géology.*—Location and character of outcrops, petrologic descriptions, probable character of bed rock under the drift cover.

*Magnetic Observations.*

*Land Classification.*

*Recommendations for Exploration.*

The township maps are arranged in successive order from south to north. The first taken is the southernmost. Then follows the tier of townships to the north beginning with the easternmost and taking in succession those to the west. The succeeding tiers are taken in the same order from east to west. It is believed that this is the most convenient order for reference, as the magnetic lines usually run somewhat north of east and the continuation of the lines in any township is most likely to be in the townships east or west rather than in those north or south.

## CHAPTER I

### GENERAL INTRODUCTION

*Authorization.*—The Wisconsin legislature of 1913 passed an act directing the Geological Survey “to examine the lands of the northern part of the state and classify them in accordance with their mineral content and geological and other evidences of the presence of mineral,” and appropriated funds for the carrying on of the work in the two succeeding fiscal years. This volume constitutes the report on the classification of the lands of that part of northern Wisconsin which was examined in the two field seasons of 1913 and 1914.

*Previous Geologic Work.*—Before the field work begun in 1913 by this Survey, very little geologic work had been done in the area covered by this report. At a very early date attention was attracted to the Gogebic Iron Range and much detailed work was done in locating its extent and determining the stratigraphic succession. This early work is outlined in Monograph XIX of the U. S. Geological Survey and to this the student is referred who desires to know the early history of geologic work on this range. The former Geological Survey of Wisconsin carried on the first detailed work and mapped the range from the Montreal river to Lake Namakagon. This work was done by Professor R. D. Irving, then head of the geological department of the University of Wisconsin, and C. E. Wright, a mining engineer. Their reports occupy pages 1 to 301 of Vol. III, Geology of Wisconsin. The next detailed work was undertaken by R. D. Irving and C. R. Van Hise for the U. S. Geological Survey and appeared as Monograph XIX above mentioned. This covered both the Michigan and Wisconsin parts of the Gogebic range. These reports referred rather briefly to the “granitic and gneissic complex” of ancient igneous rocks which was believed to occupy the area to the south as far as the Cambrian sandstones at Chippewa Falls and Grand Rapids, and as far west as the Barron quartzite.

The former Geological Survey of Wisconsin made rapid reconnaissance surveys of the Barron quartzite area, and of the Upper Flambeau valley. These were made by E. T. Sweet and by F. H.



King, respectively. Their reports comprise pages 575 to 621 of Vol. IV, Geology of Wisconsin. Good descriptions are given of the physiography and of the outcrops seen, but no attempt was made to cover the area in detail.

In 1903, Mr. Wm. Flint, of Duluth, examined the Barron quartzite for private parties and prepared a map showing the location of the many new outcrops he found. This map and the work described in the following paragraph were of assistance in helping to locate some of the outcrops.

In 1905, L. D. Burling studied the Barron quartzite for about two weeks and wrote on this subject for his bachelor's thesis.\* Mr. Burling's report summarizes the previous observations and gives an outcrop map and a structure section. Owing to the small amount of time which he could spend in the field he was not able to visit all the known outcrops and his report is consequently incomplete.

*Location.*—The area surveyed is irregular and comprises parts of Ashland, Bayfield, Washburn, Barron, Chippewa, Rusk, Sawyer, Price and Oneida counties. Its position in relation to the various productive iron districts is given on the general map, figure 1. This shows the districts mapped by the U. S. Geological Survey, by the Michigan Geological Survey, and a large area along the northern boundary of Wisconsin recently surveyed by private interests. It also shows the general area of Pre-Cambrian rocks which is not covered by the younger horizontal sandstones of Cambrian age.

*Reasons for Lack of Exploration for Iron in Northern Wisconsin.*—There are three chief reasons why only a very moderate amount of exploration for iron has been done in northern Wisconsin. The most important of these is the relatively great thickness of glacial drift and the consequent lack of rock exposures. With the exception of the Cuyuna range—the most recently developed—the productive iron ranges of the Lake Superior district center closely about localities where the ore was found outcropping by the early explorers, or by the government land surveyors, or where ore was exposed by overturned trees—found “at the grass roots.” In contrast to this most of northern Wisconsin lies close to the great terminal moraine of the latest ice invasion where the glacial deposits cover the country deeply, and in but few places do the rocks appear at the surface. Thus little could be determined as to the kind of rocks present without expensive drilling and test-pitting, oftentimes through a hundred feet or more of glacial drift.

\* Preliminary Report on the Geology of the Quartzite Formation of Barron, Gates, Rusk, and Chippewa Counties, 1905. Unpublished Thesis. University of Wisconsin.

A second reason for the small amount of exploration is that mining men for many years had comparatively little confidence in the value of magnetic attraction as a guide for exploration. This was undoubtedly due to the idea that strong magnetic attractions were considered to be the only important ones. Years of unsuccessful

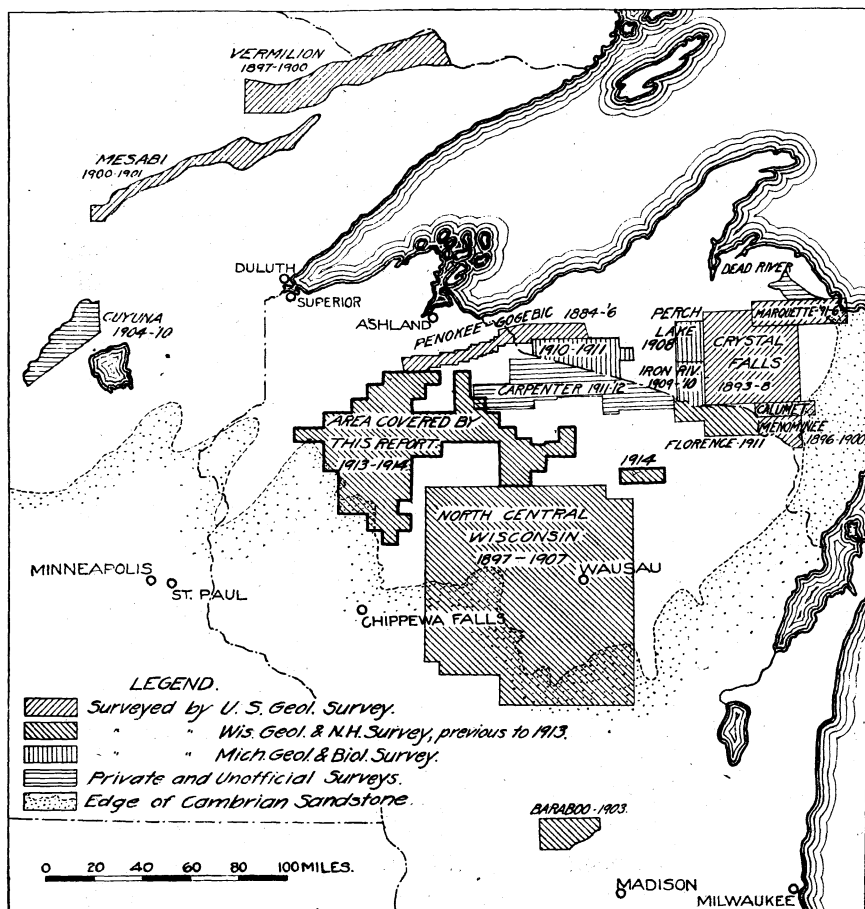

Fig. 1. Areas covered by geologic surveys in the Lake Superior Iron District.

experience in prospecting strongly magnetic areas had resulted in prejudice against all magnetic attractions. It is only since the discovery of the Cuyuna range that the real importance of magnetic data has been at all adequately appreciated. The very creditable work of Adams in developing this great range, with magnetic data

as his only guide, has decidedly altered the general opinion of the mining men. It has given respectable standing to what must be one of the most important lines of evidence to be used in the future in extending the iron-producing area of the Lake Superior region. The appreciation of the value of careful detailed surveys to get all the geologic and magnetic evidence that can be found is decidedly greater than it was ten years ago and is bound to increase in the future. If these facts had been appreciated at the time the Gogebic range was opened up this whole great pre-Cambrian area would have been gone over most carefully.

The third reason for the failure of this area to attract many explorers was the fact that in all the old ranges the ore was associated with quartzite, and the possibility of great iron ore deposits at great distances from quartzite was not appreciated. Almost all the quartzite areas in the Lake Superior region were explored to a greater or less extent before 1895. Only since the development of the Iron River and Cuyuna districts has it come to be generally accepted that a quartzite range is not a necessary accompaniment to an iron formation.

Furthermore, most of the few outcrops in northern Wisconsin were granite and other igneous rocks which were all supposed to be of an earlier geologic age than the iron-bearing formations. Consequently the crude reconnaissance maps of the early reports showed this as a great area of ancient igneous rocks in which there was no likelihood of the younger ore-bearing rocks being found. That these maps were based on a very small number of observations, and that no detailed surveys had ever been made here was not appreciated by the men interested in iron mining, and so the idea grew in their minds that it was a waste of money to search for iron south of the Gogebic range.

Fortunately this general belief is changing rapidly, and recent discoveries of ore in outlying districts, previously supposed to be barren, have convinced many that no large area should be condemned without a careful magnetic and geologic survey. The success of such surveys in leading to the discovery of several large deposits of ore in the last few years has engendered confidence, and capital is willing to follow up such surveys and to spend money in a search for ore in the favorable localities.

*Purpose of Present Work.*—The condition of affairs being as outlined in the preceding paragraphs, it was apparent that it was of the greatest importance to get the facts, so far as they could be secured,

if any intelligent search for iron ore in northern Wisconsin were to be made possible. It was known that northern Wisconsin is underlain by Pre-Cambrian rocks. Along its whole northern and north-eastern border this region is continuous with the Pre-Cambrian rocks of northern Michigan in which the iron-bearing rocks are common. It seemed quite illogical, therefore, to accept the opinion of some of the mining men that the "ore stops when it gets to the Wisconsin line," since the principal geological difference between the areas is in the thickness of drift cover, so that while exposures of rocks are comparatively numerous in the mining districts of Michigan, there are few in northern Wisconsin. Therefore, the main object of the survey was *to discover the evidence that exists as to the presence or absence of iron-bearing rocks, and as to the geologic structure of the region.*

There were three subsidiary objects to be served by the accomplishment of the main object. One was the prevention of waste of money and effort, to as large an extent as possible, by pointing out the most favorable places for exploration, and thus concentrating the attention of explorers upon places where they were most likely to be successful. Another object was to provide the assessors (who are obliged by law to value those mineral rights which are held separately from the surface rights) with as much information as could be given on the relative value of the mineral possibilities of the various parcels of land. The third object was to reduce the present practice, followed by most of the holders of large tracts of cut-over lands, of reserving the mineral rights when land is disposed of to settlers. It was known in a general way that northern Wisconsin had mineral possibilities, and so long as there was no classification of the land into "non-mineral" and "possibly mineral" the safest policy was to withhold all mineral rights. This worked a hardship both upon the settlers—as the mineral reservation acted as a cloud upon the title—and upon the holders, as they were obliged to pay taxes on a large amount of mineral rights, most of which could have no value. A careful classification of the lands will discourage the holding of mineral reservations in areas where the possibility of the presence of mineral is nil and will aid settlers in securing unclouded titles. It will also indicate to the land owners what lands offer a reasonable chance of reward for exploration and so encourage the development of an iron mining industry, if one is possible.

It must be borne in mind that the conclusions of the geologist are

but logical inferences based upon experience and study in his special field and are drawn from such facts of observation as are available. The geologist's report on a matter of this kind is of value in so far as he is thoroughly familiar with the occurrence of ore and is able to draw conclusions and see relations which are not apparent to the untrained man. If observable facts are few a fair report must so state, in order that those who rely upon his advice may be able to judge of the reliability of his conclusions. If observable facts are so limited as to permit of no conclusions this must be conscientiously brought out.

In this report it has been the purpose to give the facts as completely as possible, so that others can build upon them by closer work and more detailed observation, and to separate the facts carefully from the inferences based upon them. For this purpose a classification of lands has been adopted, as outlined in Chapter V, which gives at a glance the degree of certainty with which the conclusions were drawn. Owing to the scarcity of observable facts in many townships much of the land is thrown into Class C, which includes all the lands where the evidence for more definite conclusion is lacking.

*Area Covered and Cost of Work.*—The area covered in the field season of 1913 was nine whole townships and parts of six townships, the equivalent of  $11\frac{2}{3}$  whole townships. In 1914 there were 76 whole townships covered, making a total area equal to  $87\frac{2}{3}$  townships for the two years. This equals 3156 square miles, or 2,019,840 acres. This area is equal to nearly 50% of the area heretofore mapped by the state and national geologic surveys in the iron regions of northern Michigan and Minnesota in all the work done since the first detailed surveys were started. The total length of the regular traverses made by the geologists employed on the work was 7,100 miles.

The cost averaged about 1.95 cents per acre. This includes the total expenditure for camp equipment, instruments, supplies and salaries for the field work; the office work in preparing the maps and report for publication; and the expense of engraving and printing the maps and report. Of this 1.95 cents per acre the office work and expense of publication make up about 0.18 cents, leaving 1.77 cents per acre as the cost of the field work.

This exceedingly low cost was made possible only by very careful management and by the fact that a large area of contiguous townships were covered. Work of similar nature, but on a smaller scale

and covering non-contiguous lands, has cost private land owners from 6 cents to 12 cents per acre. Much of the credit for the low cost of this work is due to E. F. Bean and O. W. Wheelwright, who were in direct charge of the field parties.

The irregular shape of the area covered is due to a number of facts. In 1913 the work was planned to cover a strip from Prentice northward to connect with the area previously covered by private surveys, and also to see if the magnetic attractions found by these private surveys did not continue to the westward. Two parties were started from Prentice and worked northward, and one started from Butternut and worked northward. Near Prentice magnetic attractions were found which it seemed wise to trace out toward the northeast. The rapidly approaching end of the field season made it necessary to take only those parts of the towns through which the attraction could be followed. This is the reason for the long projection at the east side of the area.

The 1914 work was planned to take in the Flambeau quartzite ridge in T. 32 N., R. 7 W. and cover the area north and west to the line where the older rocks are buried by the Cambrian sandstones and the Keweenawan trap rocks, extending east to connect with the previous season's work. Three townships in the east side of Oneida and the west side of Forest counties were also surveyed in the latter part of the season to follow up some magnetic attractions which were known to exist there. These were ranges 10, 11 and 12 E., of township 36 N.

While it would have been desirable to complete a regularly shaped area before publishing a map and report, the demand for the information from land owners and others interested in knowing the possibilities for iron ore in this area makes it imperative to make the results known as quickly as possible. It is hoped that the work may be continued until a survey has been made of all that part of northern Wisconsin in which there are possibilities for the discovery of iron ore.

*Acknowledgments.*—In making a survey of this character, in two field seasons, covering over two million acres, or about 5¼% of the total area of the state, a large number of men were necessarily employed for the 3½ months of the field season. The faithful, diligent service of these men, their enthusiasm in the face of difficulties, their interest in the work which led them cheerfully to put in long hours during the day wading swamps to their waists, or hunting for outcrops in the rain, and then to spend long hours in the evening

plotting their notes on the field maps, are deserving of special commendation. Field work of this character is a strenuous combination of hard physical labor and mental activity; and when this is continued for twelve or fourteen hours per day, seven days a week, oftentimes for weeks at a stretch, until the field geologist's Sunday—a rainy day—gives a brief respite, it takes excellent qualities to measure up to the work. The names of the geologists employed are given on the maps of the townships they helped survey.

Many of the lumber and land companies and private citizens showed special courtesies to the field parties and furthered the work in a way deserving of special acknowledgment. Among these are the management of the Arpin Hardwood Lumber Co., Atlanta; the Kneeland-McClurg Lumber Co., Phillips; the Rice Lake Lumber Co., Rice Lake; the Hines Lumber Co., Winter and Park Falls; the American Immigration Co., Hayward; Mr. Wade Ackley, Winter; Mr. B. J. Nutter, Phillips; Mr. John Bronsky, Bruce; Mr. Oliver L. Olson, Weyerhauser; Mr. George Chaurette, Winter; Mr. John Owen, Prentice; Mr. Henry Johnson, County Surveyor, Hayward, and Dr. Nelson, Winter. Postmasters, bankers, railroad employees, merchants and settlers, too numerous to mention by name, all extended many courtesies and were willing to aid the parties by giving information and other favors. To all these grateful acknowledgment is made for their assistance.

Excellent work in drafting the township maps for the engraver was done by H. N. Eidemiller, G. S. Nishihara, W. L. Dobie and L. P. McGilvary. The general map, the text figures and part of the township maps were prepared by Fred W. Gillis, whose careful work deserves especial credit.

Railway profiles were furnished by the engineering departments of the respective railroads and highway profiles were supplied by the State Highway Commission. These gave much valuable data and the courtesy of the engineers is much appreciated.

## CHAPTER II

## METHODS OF DOING FIELD WORK

*Work of Geologist and Compassman.*—The field work was done by men working in pairs—a geologist and a compassman. The geologist made the observations with the dip needle, recorded them and the dial compass observations and the notes on the geology, timber and soil. He sketched a map showing as well as possible the country for a quarter of a mile on each side of the line traversed, with lakes, streams, swamps, cleared lands, houses, well data, roads, railroads, rock outcrops and all features that go to make up a complete map. In the evening the geologist inked in his notes, made a general summary of his observations of the day and plotted his results on the outline township map. On days when it was too wet to work in the brush for fear of injuring the instruments the geologist either searched for outcrops and exposures of glacial drift in the area between his traverses, or along stream courses; ran hand level lines along the roads crossing the township, to obtain data for the profiles; or worked on his notes and maps.

The duties of the compassman consisted in making a pacing traverse, finding corners (assisted by the geologist as time permitted), and making observations with the dial compass. On rainy days he assisted the geologist in his search for outcrops and exposures of drift, in running the hand level lines and in drafting the field maps and reports. By means of the pacing traverse the geologist was enabled to locate the features he was mapping in relation to the last found government land corner.

*Locations.*—The government land corners—section corners and quarter corners—were the basis of all locations. In some parts of the area the land survey was conscientiously done and most of the corners could be found, but in many townships the work was very poorly done and much difficulty was experienced in finding them. The corner stakes were never set in large parts of some townships, although the field notes are recorded in due form as though the work had been done. Lumbering operations and forest fires have also contributed to the difficulty of finding corners.



Due to the conditions described, and to the errors of the compassman in pacing, it is evident that locations must be somewhat wrong in many cases. If difficulty is met in relocating the mag-

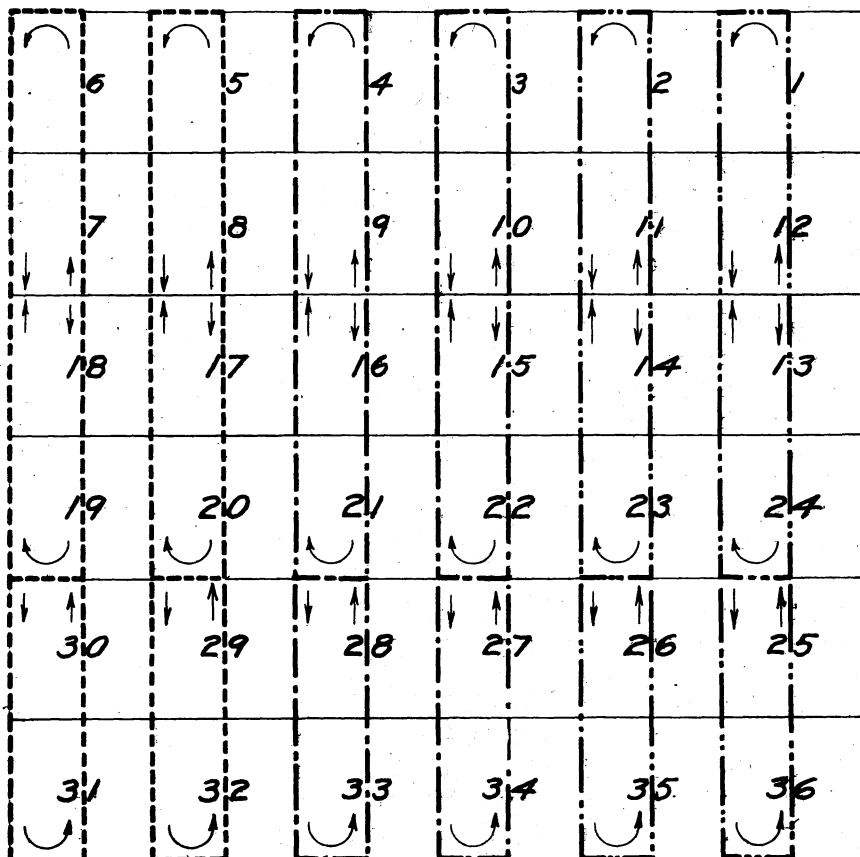

*Traverses of different geologists: - - - - , - - - - , - - - - .*

Fig. 2. This shows the usual way in which a township was divided among the geologists.

netic attractions, outcrops, or other features shown on the maps, it will probably be of assistance if some nearby feature, such as a stream crossing, the edge of a marsh, or some other easily identified place is taken as a starting point. The work was checked, so far as



A. COMPASSMAN MAKING TRAVERSE THROUGH COUNTRY FROM WHICH PINE HAS BEEN CUT.  
 Fallen logs, and the dense growth of poplar and sweet fern add much to the difficulty of the work.

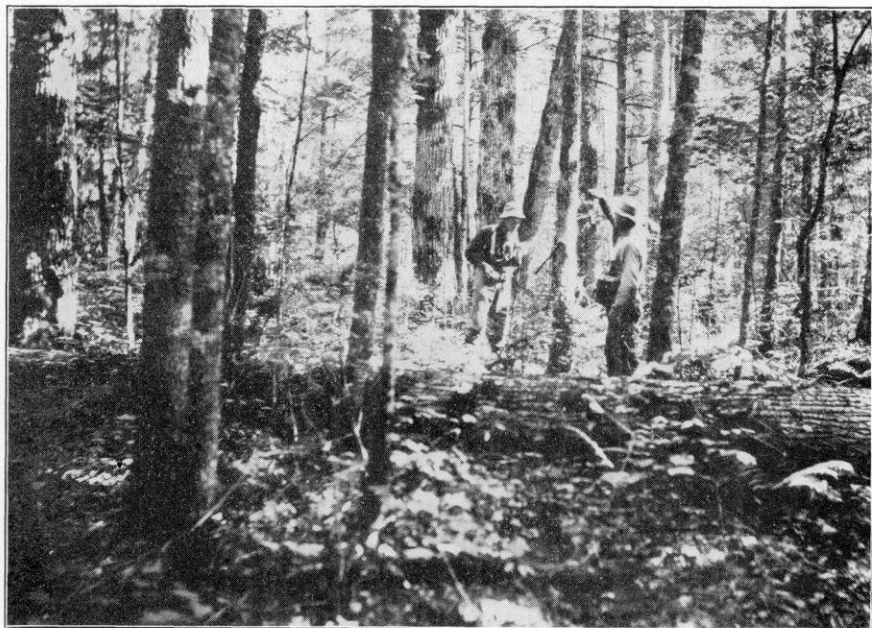

B. GEOLOGIST (ON RIGHT) READING THE DIP NEEDLE, AND COMPASSMAN (ON LEFT) READING THE DIAL COMPASS.  
 Open hardwood and hemlock forest.



it was feasible to do so, and it is believed that the locations given on the map will usually be found to be reasonably accurate.

*Organization of Field Work.*—Each party consisted of three geologists—a chief and two assistants—three compassmen, and a cook. Owing to the necessity of giving close supervision to the work, and to aid in correlating the work of the different parties, a thoroughly experienced man was put in charge of a number of parties. Mr. E. F. Bean had charge of the three parties in the field in 1913 and he and Mr. O. W. Wheelwright each had charge of five parties in 1914. These men visited the different camps as often as possible, checking up the notes and maps, going out over the work to see that the geology was being properly interpreted and keeping the parties up to a maximum of efficiency.

Each chief of party was responsible for the work of the men in his charge, assigned to them their traverses and kept the work balanced so as to have each geologist complete his share of the township at the same time as the others.

As a rule traverses were made north and south on the section lines and quarter lines. If magnetic attractions were found short traverses were sometimes made across the belt of attraction at closer spaced intervals. A fair sample of the way in which the work was done is shown in figure 2, which shows the runs made by the various men.

*Instructions for Field Parties.*—Detailed instructions were given for the conduct of the work both in the notebooks and in manuscript so that each geologist would have them available for frequent reference. The following are those given in the notebook.

## GENERAL INSTRUCTIONS

### RELATIONS TO THE PUBLIC

Every employee of the Survey is expected to conduct himself with politeness and propriety in all his relations with the public. When persons make inquiry concerning the nature of the work being done, courteous information should be given. Giving out any specific information regarding the results arrived at in the course of the work is forbidden.

## FIELD OBSERVATIONS

*Primary Purpose of Survey*

It should be constantly in mind that the primary purpose of this work is to classify the lands with regard to their mineral possibilities. The classification of each 40-acre tract seen in the day's run should be made in tentative fashion during the day or that same night. When the township map is made up the final classification should be put on every 40. A list of all 40's in classes A and B should accompany the township map and should state all evidence from geologic relations, magnetic readings, outcrops, glacial drift, and other sources, upon which the classification is based. In stating this evidence both facts and inferences should be given with a most careful distinction drawn between the two, for it should be remembered that the evidence will be scrutinized very carefully by many persons, and while the geologist's inferences can be proven wrong without serious harm, his observations of fact must be complete and above criticism.

The classes into which the land will be divided are:

*Class A*—Known to contain iron formation, shown by

1. Outcrops.
2. Tracing magnetic line from known outcrops.
3. Exploration records.
4. By contiguity or relation to known iron formation.

*Class B*—Probably containing iron formation, shown by

1. Abundant local angular iron formation drift with or without magnetic line.
2. Moderate local drift of iron formation with a good magnetic line.
3. Magnetic lines known to be associated with slates or other Huronian sediments.
4. Geological relationships showing a succession which elsewhere contains iron formation but shows no magnetic line or other evidence.

*Class C1*—Probably underlaid by Huronian rocks and crossed by magnetic lines having continuity and a fair degree of uniformity.

*Class C2*—Possibly underlaid by Huronian rocks but having either no magnetic lines, or very irregular magnetic lines, and no other indications of iron formation.

*Class D*—Containing no iron formation.

1. Includes areas of rocks not associated with iron formation, such as granites, etc.

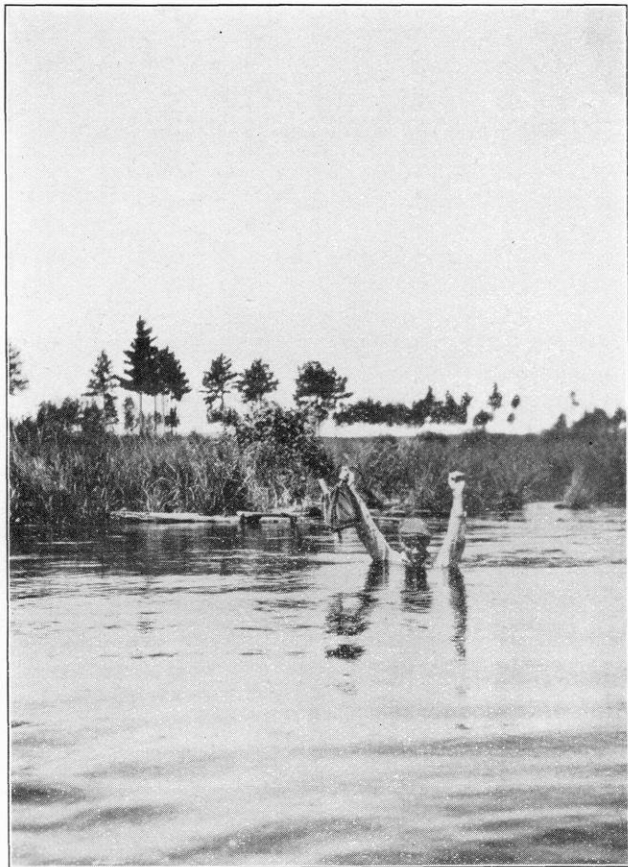

A. GEOLOGIST CROSSING A STREAM.

In making traverses it is frequently necessary to wade or swim.



B. COMPASSMAN TAKING A SIGHT THROUGH POPULAR BRUSH, WHICH FORMS A THICK COVERING AFTER THE PINE IS REMOVED.

Short sights are necessary and progress is slow in country of this character.



## NOTE BOOK

As a rule the center line of the right-hand page should be used for the east line of the section, and the center line of the left-hand page for the center line of the section. This permits all information pertaining to forties on either side of the traverse to be recorded on a single page. Be sure to indicate clearly the section corners, whether "found" or "not found," how they are marked, and your pacing distances between them, and to fill in all blank spaces at top and bottom of page.

*Notes on Geology.*—On the ruled pages following the map pages should be recorded all observations that apply to the forties on the map pages.

The work should be so arranged that the notes on a single township are in one set of notebooks, so that they, together with the township report, may be turned over to the chief of field parties, and new notebooks used for the next township.

Be sure to put on the field map everything desired for the final map, so that the draftsman can copy your map and have it correct without asking questions. The best time to write up your observations is when you are making them. "The field geologist should always bear in mind the fact that he will probably never again see the particular locality he is studying, and should therefore aim to make his observations so thorough that he will never again need to see it." Use sketches freely in your notes.

## TOPOGRAPHY

In this area the glacial symbols will be used to indicate the nature of the topography. Streams, swamps and lakes should be indicated by proper symbols. (See list of symbols and abbreviations.) Use solid lines to show streams, swamp boundaries, etc., as far each side of the traverse as you know their locations, and show their probable extensions for  $\frac{1}{4}$  mile to the right and left by dotted lines. Be careful to show correctly on your map the width of the larger streams. Always indicate your estimate of the height of hills, depths of valleys, etc.

## CULTURE

Show clearings, houses, roads, railroads, old explorations, test pits, etc. (See list of symbols and abbreviations.) Always get depth to water in wells and inquire of owner for changes in level, dates, etc.



## MAGNETISM

In general a careful reading of the dip needle should be made at least every fifty paces. The horizontal deflection should be read at least every 100 paces. When a magnetic line is crossed, indicate in the notes your opinion as to the strike and dip of the formation, if you are able to form any from the readings. These deductions should be correlated with structure whenever outcrops are present. The magnetic line should always be sketched in the field. This line should be crossed at frequent intervals so as to determine its location and characteristics in detail. Readings of the dip and dial should here be made at closer intervals. Record magnetic variations at the right or upper side of line of traverse, always indicating amount and direction of deflections, as 4E, 8W. Ink these in your note book with black. Dip readings should be recorded at the left or below the line of traverse. Ink these in your note book with red.

## GLACIAL GEOLOGY

*General*

All exposures of glacial drift in cuts and elsewhere, where the vegetation permits, should be carefully examined for evidence of the character of the local bed rock. Slate fragments are seldom carried far, and angular fragments of dolomite, iron formation, or quartzite, are not usually found in abundance at a great distance from their source. Abundance of any kind of boulders is worthy of record. There should be at least one note recording the nature of the drift for every 40-acre tract.

1. *Direction of Glacial Movement.*—Observe striae, stoss and lee slopes, trend of drumlins and eskers, and transportation of erratics.

2. *Erosion Features.*—Observe glaciated surfaces—polishing, gouging, striation, plucking, etc.

3. *Pre-Glacial Topography.*—Note carefully any evidence, such as pre-glacial channels, as this may have a bearing on structure.

*Glacial Deposits*

1. *Ground Moraine*—Indicate relief by the proper symbol, and by figures giving range in elevation in feet. Get all the evidence you can from wells, road and stream cuts, etc., as to character, thickness and age of drift, soil beds, vegetable or animal remains found below drift, etc.

2. *Terminal or Recessional Moraine.*—Show on your map the width and general trend of the terminal moraine belt. Be sure to indicate in your notes any facts which could be used in interpretation of the glacial geology.

3. *Outwash and Lake Deposits.*—Indicate extent. If there are abandoned stream channels, indicate their direction. If there are pits, describe them. The trend of boulder trains and their relations to rock outcrops should be recorded.

4. *Drumlins, Eskers, Kames.*—Observe height, general direction and length. Note distribution relative to terminal moraines, to other drift features or to pre-glacial topography.

5. *Loess.*—Observe thickness, relations to glacial drift, topography and drainage lines.

## PETROLOGY

### *General*

Record location of outcrops with reference to a government corner. The area and trend of the outcrop should be plotted on the map. Standard sized samples should be taken from each outcrop to show the various phases, such as weathered, unweathered, gradations, metamorphism, etc. Be sure to sketch in the field all formation boundaries indicated by contacts, topography, or other evidence. If field determination of the rock is doubtful, give best judgment as "probable." Give all possible hypotheses of structure. *Remember that in the field you are in a far better position to describe an outcrop adequately than you will be at any later time.*

### *Igneous Rocks*

Origin and petrographic character. Structure and relations to other rocks, including jointing, schistosity and general metamorphism.

### *Sedimentary Rocks*

Petrographic character, constituent minerals; size, shape and color of grain; cement, gradations.

1. *Bedding.*—Ripple marks, cross-bedding, conglomerate, top and bottom of beds, etc. Note predominant direction of currents causing cross-bedding.

2. *Structure*.—Dip and strike of beds; pitch, length and direction of folds; relation of drag folds; faults, joints, cleavage-dip and strike, in zone of flow or fracture; secondary minerals, etc.

3. *Fossils*.—Presence and abundance.

## SOIL

Always mark the soil classification of every 40 the day the work is done. Preferably, this should be done at the end of every one-fourth mile. The classification of soil which will be used is:

1. *Clay Soil*—25 to 50 per cent of clay and the remainder silt, sand or gravel.

2. *Loam*—10 to 25 per cent of clay, a large proportion of silt, and the remainder fine to coarse sand and gravel.

3. *Sand Soil*—Generally less than 10 per cent of clay, a small amount of silt, and a large amount of fine to coarse sand.

4. *Stony or Gravelly Soil*.

5. *Muck and Peat Soils*.







In addition to the above classes there are intermediate phases, such as, sandy loams, loamy sands, sandy clays, etc.

## TIMBER



















There should be at least one note giving the kind of vegetation on each 40-acre tract, such as cultivated, hardwood, pine, slash, brule, sweet fern, etc.

## Symbols













### Exposures

	drift
	boulders and talus
	sediments without dip and strike
	sediments with dip and strike
	igneous rocks
	gneiss and schist with dip and strike
	dip and strike of secondary structures

### Cultural and Economic

	building
	church
	school
	town hall
	quarry
	shaft
	pit
	opening in drift
	well, non-flowing
	flowing well in drift
	flowing well in rock
	exploration drill hole
	roads
	little used roads
	trail
	railroad
	dump of excavated material
	dam

### Topography

	gently undulating
	roughly undulating
	gentle slope showing direction
	steep slope showing direction
	cliff
	gentle sags and knobs
	pronounced sags and knobs
	flat
	flat with sags
	wet land
	spring
	dunes

## ABBREVIATIONS

## Surficial Geology

A	Alluvial wash
B	boulders
Cl	clay
D	drift
G	gravel
L	loess
M	marl
P	pebbles
Pt	peat, etc.
S	sand
T	till

## Igneous Rocks, etc.

Br	breccia
Bt	basalt
Db	diabase
Dr	diorite
Ga	gabbro
Gn	gneiss
Gr	granite
Gs	greenstone
Po	porphyry
Ry	rhyolite
St	schist
Sy	syenite
Tr	trap

## Characters

arg	argillaceous
brk	broken
cal	calcareous
crb	carbonaceous
crs	coarse
cty	cherty
fer	ferruginous
frg	fragments
fri	friable
hrd	hard
sft	soft
sid	sideritic
sil	siliceous
stk	sticky
wth	weathered

## Sedimentary Rocks

ak	arkose
cg	conglomerate
ct	chert
dl	dolomite
gd	greensand
gw	graywacke
if	iron formation
ls	limestone
qt	quartz
qz	quartzite
rk	rock
sh	shale
sl	slate
ss	sandstone
tv	travertine

## Soils

cl-l	clay loam
sdyl	sandy loam
lt cl-l	light clay loam

## Textures and Structures

amg	amygdaloidal
gns	gneissic
por	porphyritic
sch	schistose
str	stratified
tkb	thick bedded
tnb	thin bedded
xb	cross bedded
xln	crystalline
xln-c	coarsely crystalline
xln-f	finely crystalline

## Colors

bf	buff
bk	black
br	brown
bu	blue
dk	dark
dr	drab
gn	green
gy	gray
lt	light
rd	red
wh	white
yl	yellow

In addition to the general instructions printed in each notebook, manuscript instructions in greater detail were given to each party as follows:

## SPECIAL DIRECTIONS

*Directions to Chief of Party*

Much of the success of the party depends upon the ability, enthusiasm and leadership of the chief. In addition to planning and supervising the work of the party he will have the responsibility of selecting well-drained camp sites, seeing to it that sanitary conditions are maintained, that proper care of equipment is taken, that his men keep clean and as neat appearing as possible, that all men are courteous in their dealings with the public, and that the party is properly fed at moderate cost.

It is absolutely necessary that the chief have a watch that keeps nearly perfect time. For that reason he should have his watch cleaned and carefully regulated before going into the field.

*Notes.*—Inspect the notebooks daily to see that the geologists are making the best possible notes and maps, and that these notes are kept inked in. See to it that the men are thoroughly familiar with the general instructions, symbols and abbreviations found in the first pages of the notebook.

Read carefully the instructions on magnetics and the general directions. See to it that all the men become thoroughly familiar with them. In addition to the daily discussion of field work you will find it very profitable to hold an occasional conference in which you quiz the men concerning these instructions.

*Tenure of Jobs.*—No man can hold his job if he does not make good. If a man's work is not up to standard, warn him, aid him in every way you can and try to improve his work. Consult with your chief or field parties, so that he may be prepared to replace undesirables with new men.

*Care of Equipment.*—You will be held responsible for the equipment furnished you. Itemized lists of Survey property accompany each camp outfit. Check over these lists and report any shortage. You will be checked out at the close of the season.

*Accidents.*—As soon as you get in camp, secure from each member of your party the name and address of the person to be notified in case of accident. All precautions will of course be taken to avoid accidents, but your men should have in mind just what to do in case an accident occurs. In your camp chest is a small book, describing first aid to the injured. All men should be familiar with this. There is also a small emergency medical outfit. Be familiar with its contents and insist that it be kept for emergencies.

*Planning Work.*—Plan the work from each camp so that each geologist has a block of sections. In this way he can be held responsible for the geology and physiography of his area. If the camp were located at the corner of 21, 22, 27 and 28, one geologist might be assigned sections 13, 14, 23, 24, 25, 26, 35 and 36; another, 15, 16, 21, 22, 27, 28, 33 and 34, and a third, 17, 18, 19, 20, 29, 30, 31 and 32. Care should be taken, so that the geologist who has a difficult area in one camp, will be given an easier one in the next camp.

Except when working in a region known to have magnetic attractions, the work will be continued daily unless rain prevents. If clouds prevent taking dial readings, the traverse may be continued, using the normal variation of the needle, and taking dip needle readings as usual. In case of known or suspected magnetic attraction, the traverse should be stopped, if the day is too cloudy to take dial compass readings, and completed when they can be taken. If necessary to stop the traverse because of cloudy or rainy weather the time can be used to advantage in running hand level lines or in examination of drift exposures and outcrops.

*Weekly Reports.*—On the paper township plats furnished make two weekly reports, each showing (a) magnetic lines and outcrops, (b) daily work of each member of the party, (c) mileage of each geologist for week, and (d) total mileage for season. Mail one report to the Survey office at Madison, and the other to your chief of field parties.

*Township Reports.*—You are responsible for the report on each township your party surveys. The preparation of this should be divided between yourself and assistants and written during the progress of the work while the facts are fresh in mind. Discuss fully with the members of your party all facts entering into the report. Free discussion of the facts observed will stimulate the interest of both your assistants and yourself and will lead to greater interest in the work and keener observation. Writing the report while you are still camped in the township permits checking up of doubtful or disputed points while you are right on the ground.

It should be borne in mind that failure to mention a subject in your report can only mean a failure in observation. You must carefully guard against the common failing of thinking that such treatment means that the subject is "the same as described in the last township." Failure to mention outcrops means only that you do not mention them. If there are no outcrops or exposures of glacial drift in the township omitting reference to them is not equivalent to stating their absence. *It is important to forcibly impress upon your own mind and upon your assistants' that positive statements are necessary.* When finished the report should be sent to your chief of field parties.

The township report should be an accurate, concise, but complete report upon the following outline:

1. *Magnetics.*—Trend of lines and all deductions you are able to make regarding structure of underlying rocks and cause of attraction.

2. *Rock Outcrops.*—Careful description, giving location and size of outcrops, structure and a good petrologic description of each.

3. *Land Classification.*—In this be careful to state carefully the evidence upon which you base your classification. See instructions in notebook.

4. *Glacial Geology.* (a) Ground Moraine.

Topography.

Character of drift, mechanical analysis.

Drainage.

- (b) Terminal Moraine.
  - Trend and extent.
  - Elevation above ground moraine or outwash.
  - Topography.
  - Nature of material, mechanical analysis.
- (c) Outwash.
  - Extent.
  - Topography.

### 5. Soil and Timber.

*Township Maps.*—Accompanying the township report must be three field maps made on the blank township plats furnished. Each traverse should be plotted upon the township plats as quickly as possible after it is completed. The purpose of this is (a) to enable you to plan your work more intelligently and (b) to enable you to finish the maps in a very short time after the completion of the survey. This work may be done evenings, on rainy days, or when compasses are corrected. The three maps should show the features named below.

1. Map showing Geology and Magnetics. Study specimen map furnished you. (Scale 2 in.=1 mile.)

- (a) Drainage and culture.
- (b) Magnetic readings and lines.
- (c) Geology—Rock outcrops, with dip and strike, formation boundaries, predominant varieties of rocks represented, boulders of iron formation or ore, shafts, drill holes, pits, etc.
- (d) Explanatory statements as on sample map.
- (e) Classification of lands. Put this on in pencil only. (See instructions in notebook on the classification to be made.)

Note: In making this classification it is desirable to represent the gradation between classes which the geologist will have in mind, e. g. is a certain 40-acre tract B+ or A—. These should be recorded only in the notebook and the unmodified letters used on the township map.

2. Map of Surficial Geology. Study specimen map. (Scale 2 in.=1 mile.)

- (a) Topography and culture.
  - Use topographic symbols to represent surface features.
  - Use figures to indicate height or depth with relation to surroundings. Map should give a good, general idea



of the surface of the township and the more important single topographic features. Rough contours should be used, when possible.

- (b) Glacial Geology. Sketch the outlines of terminal moraines, show extent of ground moraine, outwash, etc. Location and trend of drumlins and eskers, trend of striae, boulder trains, etc.
3. Soil and Timber Map. (Scale  $1\frac{1}{4}$  inch to mile.)
- (a) Soil. Make a general subdivision of the township into soil belts or areas.
  - (b) Timber. Make a general classification of the timber. Put a small x in center of all isolated cut-over 40's, and outline large cut-over areas. Indicate cleared 40's by a small circle in center of 40.
  - (c) Culture.

Note: Large areas of any particular classification should be outlined and the classification shown in large letters. Scattered or isolated parts of any classification should have the classification shown on each 40.

#### DIRECTIONS FOR GEOLOGICAL AND TOPOGRAPHIC OBSERVATIONS

*Exposures of Rock or Glacial Drift.*—These are likely to be found along streams, road or railroad cuts. Odd time should be utilized in the search for these, such as the last few clear hours of a rainy day, or cloudy weather when working where it is necessary to have sun for dial compass readings. A rough pacing traverse should be made so as to give an approximately correct location for such features as are found. Every rock outcrop should be visited and inquiry should be made of the local people to see if they know of any that you have not seen.

*Specimens.*—Standard sized specimens (about 4" x 3" x 1"). should be taken from each outcrop to show the various phases, such as weathered, unweathered, gradations, metamorphism, and such other features as should be shown.

Each geologist will carry a number of paper bags in which to wrap specimens. Put the specimen number on the bag with blue pencil in several places, so that identification may be certain. Put this number on the map and in the margin of the notes descriptive of the specimen. Ink these notebook numbers in black. *Be sure*

to make the rock descriptions as complete as possible, so that even if the specimen is lost your identification may be used. Make your petrologic descriptions quantitative rather than qualitative. When you say "coarse grained" you are comparing the size of grain with some standard in your mind, which no one else can know definitely. Instead of "coarse grained" use dimensions, as "crystals average  $\frac{1}{4}$  inch in diameter." Endeavor in every way to make your observations definite in this way so that they convey clean cut ideas to one who has not seen the thing described. This is the secret of good notes, and of good observation as well, for to express a thing definitely you must first see it definitely. The act of writing some obvious things will often suggest other less obvious things.

The description of the locations should be such that the outcrops may readily be found by anyone making a later study.

#### OBSERVATIONS ON EXPOSURES OF GLACIAL DRIFT

1. *Nature of Exposure.*—Railroad, stream or road cut. Depth of cut. New or old. In the latter case it is well to dig through the surface covering to determine the structure and materials.

2. *Composition of Drift.*

(a) Materials—clay, boulder clay, gravel, sand, loess, etc. Estimate percentages of the total volume made up by the boulders, pebbles, and fine material, sand or clay.

3. *Structure of Drift.*

Stratified:

Outwash or terminal material.

Thickness of strata.

Direction and velocity of currents.

Unstratified. Loose or compact.

4. *Weathering.*—Color of weathered and unweathered drift. If there is a weathered zone, examine the weathered pebbles, noting varieties of rock to see if the type of rock does not determine the amount of weathering, and thus give an older appearance to drift which is in reality no older than fresher appearing drift made up of more resistant rock. Note depth to which leaching is evident. Is the drift unconsolidated, well cemented or poorly cemented?

5. *Rock Represented in Boulders and Pebbles.*—

(a) Mechanical analysis of drift. One good method is to lay off an area two or three feet square, and pick pebbles

under three inches in diameter from this. Care must be taken to make this count a truly representative one. If too large pebbles are selected, slate and other soft rock fragments will be overlooked. Pick 100 pebbles at random over this area and classify them, as: granite 87%, quartzite 11%, porphyry 2%. Such a count is valuable because it may show what the dominant local rock is. A number of counts taken in the same locality when studied in relation to known outcrops, may indicate the general direction of glacial movement.

- (b) **Erratics.** Care should be taken not only to note the common types of erratics, but also to note the occurrence of a distinctive type of rock which may be traced to a definite locality and thus give evidence regarding direction of ice movement. If the observer recognizes the rock, he should give its probable source; if probable source is not known, describe rock carefully or take sample.

#### 6. *Difference in Age Indicated By*

- (a) Forest beds.
- (b) Remains of land animals.
- (c) Inorganic products formed during a time of ice recession, as bog ore.
- (d) Beds of lacustrine origin.
- (e) Beds of sub-aerial gravel, sand and silt.
- (f) Differential sub-aerial weathering.
- (g) Superposition of beds of till of different physical constitution.

*Observations on Topography.*—Be on the alert for any evidence of pre-glacial topography, as this may have a bearing on structure. The course of a pre-glacial valley, especially if wide, was probably determined by less resistant formations, such as slate or iron formation. Present drainage may or may not follow pre-glacial drainage lines, but a valley, now occupied by lakes, streams and swamps or by one or more of those, with the peneplain surface rising above it, may mean a pre-glacial valley. If such a valley has rock outcrops on one side and the strike coincides with the trend of the valley, you have some evidence as to the structure in the valley, even though no magnetic lines are found there. Again, if there are no outcrops in the upland, but a magnetic line is found which has the same general strike as the valley, you may feel quite certain that the valley

is pre-glacial, and that the underlying rocks are non-resistant. If there is a magnetic line in the valley, you have evidence that possibly indicates iron formation. A broad lowland surrounded by higher land with resistant rocks outcropping, may be safely assumed to be underlain by non-resistant rocks, such as schist, slate, soft iron formation, etc. You should endeavor in every way to correlate magnetics, geology, glacial geology and topography.

The topography should be studied for evidence of the age and thickness of the drift. Well data should be secured wherever possible. *Data for wells which do not go to rock show that the drift is at least of a certain minimum thickness.* If the drift is thin, the pre-glacial topography is slightly modified, while a thick sheet quite often obliterates the former topography.

The amount of post-glacial modification gives evidence of the age of the drift. If young, lakes and swamps are abundant, drainage channels are very shallow, and there is very little gulying on the hill slopes. In older drift lakes are fewer in number, and their shore features and swampy borders bear evidence of former greater extent. The depth of stream channels also is greater and drainage is in general better defined.

*Hand Level Lines.*—In spare time, such as compass correction days, or days not suitable for magnetic work, hand level lines should be run along the roads of the township, preferably so as to give an E-W and N-S profile across the township and connect with similar profiles in adjoining townships. In doing this it is most convenient to use a ten-foot pole as a rod, on which the height of the instrument man's eye is taken as the zero.

#### SPECIAL CAUTIONS FOR MAGNETIC OBSERVATIONS

*Manner of Holding Dip.*—The geologist must hold the side engraved "W. & L. E. Gurley" to face the east and should himself always face the west when taking readings. Each man must be thoroughly familiar with Chapter IV.

*Setting of Declination.*—When the meridian has been established, determine the declination of each instrument and move the circle around until  $0^\circ$  coincides with magnetic north, and **fasten** the circle securely.

*Precautions to Secure Uniform Conditions.*—Be sure that the compassman always stands in a constant position when reading the dial, that his axe, knife and knapsack are always carried in the same

place. The geologist should take the same precautions with his load. Water bottles should be stripped of their metallic covers, if they have such, and a canvas cover substituted. These precautions are absolutely necessary.

*Time.*—Take the utmost care with time. Before starting in the morning all watches should be compared with the best time keeper, and set accordingly. The table of corrections should be changed from day to day to keep step with the equation of time. To avoid losing a valuable watch, each man should have his watch on a thong, rather than on a chain or fob. If water gets in a watch, put it in kerosene until it can be sent to a jeweller. Compassmen must provide themselves with reliable time-keepers.

#### MISCELLANEOUS DIRECTIONS AND CAUTIONS

*Blazing.*—When an original or re-established corner is found, blaze section lines 100 paces each way from the corner. Make a fresh blaze at corner and print W. G. S., date, and the proper description of the corner as,

Cor.  $\frac{2}{11} \mid \frac{1}{12}$  T. 42 N., R. 14 E. or  $\frac{1}{12}$  S.  $\frac{1}{12}$  T. 42 N., R. 4 W.

When the original or re-established corner is not found, blaze lines in the same manner from the point where the pacing would indicate the corner should be. Do not mark this as a corner but mark it as "1000 paces N. of E $\frac{1}{2}$ S, section 21," etc., so that others who find the blazes later will not be misled by them.

*Photographs.*—The Survey desires a moderate number of photographs in each town—say six to ten—showing both the *usual* features that are characteristic of the topography, timber, etc., and the more striking *unusual* features that exist. If you have a camera the Survey will pay for films and developing. Exposed films should be mailed to Madison for development. As many prints as desired may be had by the camera owner at the cost of prints. Take time exposures with small aperture wherever possible, as these give best results.

*Forest Fires.*—The greatest care must be taken to prevent forest fires. No matches should be dropped without seeing that all fire is out. If a fire is built for any purpose, be sure that it is extinguished when left. Cigarette smokers must make sure that butts are thoroughly extinguished before being thrown away.

*Fire Arms.*—These are **not at all** necessary in camp. If any are brought to camp, **great care** should be taken in their use, so that no accidents occur. It shall be **distinctly** understood that as employes of the state you must **obey not only** the spirit but the letter of the game laws.

### CHAPTER III.

#### GENERAL GEOLOGY

*Introductory Statements.* The rocks of the earth's crust are so largely concealed by soil, glacial drift or other unconsolidated material that in few regions of great extent is any large proportion of the surface occupied by rock exposures. In mapping the geology of a district it is almost always necessary to extend an inference drawn from a few square feet of rock exposure to cover many acres, or sometimes many square miles. All the evidence afforded by every feature of the surface—topography, drainage, soil and vegetation—and also whatever other evidence is available, such as magnetic attraction, must be used to supplement the information given by outcrops. Even after most painstaking search for the facts it must be recognized that probably most of them are beyond the possibility of discovery by means ordinarily at the command of the geologist. For the foregoing reasons it is obvious that the description of the geology of any large area will require modification as new facts are developed.

In the area discussed in this report there are over 2,000,000 acres or the equivalent of 87 townships. In 44 townships no rock exposures of any kind were found. Outcrops of rocks older than the Barron quartzite were found in but 33 townships. It is estimated that the total exposed area of rocks of all kinds does not exceed 300 acres. This is less than  $1/67$  of 1 per cent. of the area mapped. With the small amount of information available from rock exposures it was obviously impossible to map accurately the limits of the various rock formation present.

For the purpose of classifying the lands one of the most important criteria available is the local magnetic attraction, which is found widely distributed over the area surveyed. By carefully tracing this attraction and studying the observations in detail it is possible to outline areas in which it is practically certain that Huronian sedimentary rocks, including iron formation, are present. The mapping of these areas depends upon the general principle that magnetic sedimentary rocks in the area south of Lake

WISCONSIN  
GEOLOGICAL AND NATURAL HISTORY SURVEY  
E. A. BIRGE, DIRECTOR W. O. HOTCHKISS, STATE GEOLOGIST

# MAP SHOWING GEOLOGY OF PART OF NORTHWESTERN WISCONSIN

INCLUDING PARTS OF  
ASHLAND, BAYFIELD, WASHBURN, SAWYER,  
PRICE, ONEIDA, BARRON, RUSK, AND  
CHIPPEWA COUNTIES

BY  
**W. O. HOTCHKISS**  
ASSISTED BY  
**E. F. BEAN AND O. W. WHEELWRIGHT**  
1915

SCALE: 6 MILES = 1 INCH

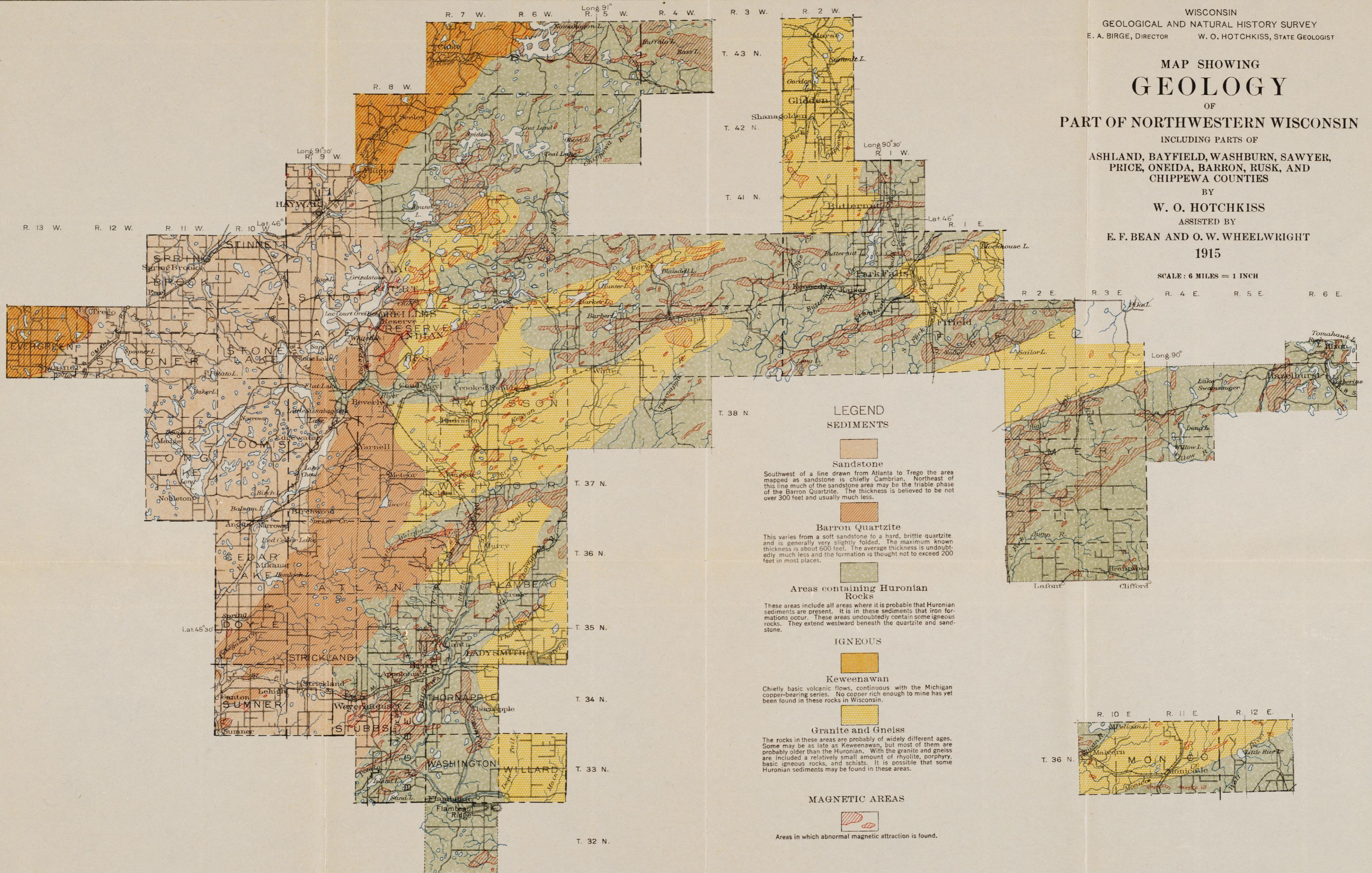

### LEGEND SEDIMENTS

 Sandstone

Southwest of a line drawn from Atlanta to Trego the area mapped as sandstone is chiefly Cambrian. Northeast of this line much of the sandstone area may be the friable phase of the Barron Quartzite. The thickness is believed to be not over 300 feet and usually much less.

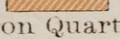
 Barron Quartzite

This varies from a soft sandstone to a hard, brittle quartzite and is generally very slightly folded. The maximum known thickness is about 600 feet. The average thickness is undoubtedly much less and the formation is thought not to exceed 200 feet in most places.

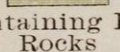
 Areas containing Huronian Rocks

These areas include all areas where it is probable that Huronian sediments are present. It is in these sediments that iron formations occur. These areas undoubtedly contain some igneous rocks. They extend westward beneath the quartzite and sandstone.

### IGNEOUS

 Keweenaw

Chiefly basic volcanic flows, continuous with the Michigan copper-bearing series. No copper rich enough to mine has yet been found in these rocks in Wisconsin.

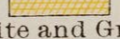
 Granite and Gneiss

The rocks in these areas are probably of widely different ages. Some may be as late as Keweenaw, but most of them are probably older than the Huronian. With the granite and gneiss are included a relatively small amount of rhyolite, porphyry, basic igneous rocks, and schists. It is possible that some Huronian sediments may be found in these areas.

### MAGNETIC AREAS

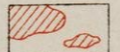
 Areas in which abnormal magnetic attraction is found.

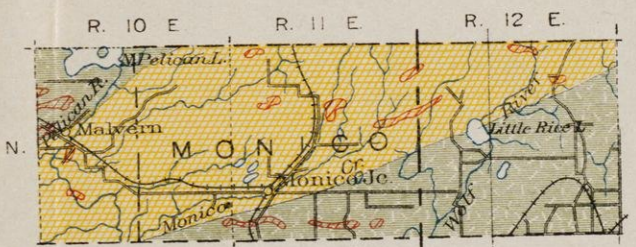



Superior are known to occur plentifully only in the Huronian series, in more or less close association with iron formations, therefore the finding of magnetic attractions of a kind usually caused by sedimentary rocks justifies the mapping of such areas as underlain by Huronian rocks.

Unfortunately, however, the details of the geology of most of the area must remain a sealed book. This is due to the thick covering of glacial drift which fortunately is of such a character as to add greatly to the value of the region. It makes an excellent farming country out of what otherwise would have been a more rugged barren region. The drift has levelled the inequalities of the surface and given it a soil which is almost certainly much better than the pre-glacial soil. It is an undoubted fact that the value of the soil is greater in the long run than the value that may exist in ore, and if the choice were to be made it would be better to have a rich farming country developed in this area than to have a rich iron range. A rich soil will support many people continuously, while a mining district must sooner or later be exhausted and lose its value. So it is not to be regarded an unmitigated misfortune that the thick drift cover probably will prevent the discovery of much iron ore that might be found if the drift were absent. The most desirable situation for the future of this region will be to have both the soil and the mineral resources developed to the greatest possible extent.

## GEOLOGIC FORMATIONS

The rock formations of the area shown on plate I are given in the following table, youngest first:

*Cambrian*.—White, yellow and light brown sandstone, poorly cemented.

*Keweenaw*.—Barron quartzite and sandstone including at least two separate unconformable quartzite formations, trap rocks and probably both acid and basic intrusives.

*Huronian*.—Flambeau quartzite, chert and iron formation at Bruce, and slate and schist in several localities. Possibly granite and basic intrusives. Iron formations and slates shown in many places by magnetic data but not exposed.

*Laurentian*.—Granite and gneiss in large areas, forming the base upon which the Huronian was deposited.

This geologic column is necessarily incomplete because of the few exposures, and no attempt is made to state the order of the Huronian succession, but there is little reason to doubt that in such a large area a nearly complete pre-Cambrian succession will be found.

In the Lake Superior region, of which this area is a part, geologic formations older than the Keweenawan have in many cases been profoundly altered from the condition in which they were originally deposited. They were covered by thousands of feet of other rocks which have been eroded away. The deep burial and consequent pressure to which they have been subjected, the crumpling and folding, the intrusions of igneous rocks, and the action of water have changed their original character in varying degree. In some places they are so much altered that it is difficult to determine their original character. In others they are changed comparatively little.

These rocks include both igneous and sedimentary formations and comprise all the common and some uncommon types of rock. It may be stated that at least three quarters of the total thickness of sediment is shale or slate. The remainder is made up of dolomite, quartzite, and iron formation. The igneous rocks are of many varieties varying from acid to basic and from coarse crystalline varieties to the fine-grained surface flows and volcanic tuffs. In order to give an idea of what pre-Cambrian formations may be found in this area and their relative age the following table is given, showing the geologic columns of several of the producing iron ranges.

Series and Group		Crystal Falls District	Florence District	Penokee-Gogebic District	Baraboo District	
Algonkian System	Keweenaw Series	Upper		Absent		
	Middle	Not identified	Granite and gneiss (Keweenaw?)	Gabbros, diabases, etc.		
	Lower			Conglomerates Unconformity		
	Upper Huronian (Animikie group)	Greenstone intrusives and extrusives. Michigamme slate, with its Vulcan iron-bearing member	Quinnesec schist, greenstone intrusives and extrusives. Michigamme slate, including quartzites of doubtful age, and Vulcan iron-bearing member	Greenstone intrusives and extrusives. Tyler slate. Ironwood formation (iron-bearing) Palms formation	Quartzite (upper Huronian?)	
	Middle Huronian	Unconformity? Negaunee (?) formation (iron-bearing) Ajibik quartzite Hemlock formation (volcanic), with iron-bearing slate member near top	Not identified	Absent	Unconformity Granite, intrusive into lower formations Freedom dolomite, mainly dolomite, including iron-bearing member in its lower horizon Seeley slate Baraboo quartzite	
	Lower Huronian	Unconformity? Randville dolomite Sturgeon quartzite	Not identified	Unconformity Bad river limestone (cherty limestone) Sunday quartzite	Absent	
	Laurentian series (intrusive into Keewatin)	Unconformity Granites and gneisses		Unconformity Granite and granitoid gneiss.	Unconformity Granites, rhyolites, tuffs, etc. (Laurentian?)	
	Keewatin series			Greenstones and green schists		
	Archean					

\*From Table facing page 598, Mon. LII, U. S. G. S.

The descriptions of the principal formations outcropping in this area are given in the following pages. The sediments are first described, the youngest first, and then the igneous rocks are taken up in the same order.

#### SANDSTONE

The sandstone is found in the southern and western portions of the area as shown on the map, plate I. It is known chiefly from its occurrence in wells, as it is very soft, and outcrops are found only in exceptionally favorable places.

*Outcrops* are found in three townships; on the bank of the Flambeau river in the east side of T. 34-7W.; at Atlanta in T. 35-7W., and at several places in T. 34-10W. Wells in sandstone are known in T. 34-8W., T. 34-10W., T. 35-7W., T. 35-8W., T. 36-10W., T. 37-10W., T. 37-11W., T. 38-11W., in section 1, T. 38-12W. (This is just outside the area mapped); in section 28, T. 39-13W., and at Hayward in T. 41-9W. Numerous blocks of sandstone, evidently not far from ledge, are found on the northeast side of Grindstone Lake in T. 40-8W.

On account of the meager data the sandstone boundaries cannot be drawn with any degree of assurance. In most of the area mapped as sandstone it probably occurs as a thin cover over the older rocks. How continuous this cover is, or exactly how far it extends, cannot be told because it is obscured by the glacial drift. The boundary east of Hayward is drawn on the basis of magnetic data. As the magnetic lines are traced from the northeast they become weaker and weaker, as though the magnetic formations were being covered by an increasing thickness of younger non-magnetic rock. It is entirely possible that a tongue of the sandstone may extend to the northeast to or beyond Spider Lake in T. 42-7W., but no evidence of this was found.

The east side of the sandstone is indicated by the angular quartzite drift and the elevated topography which mark the western boundary of the quartzite. Topography, well records, and magnetic attractions serve to indicate much more closely the extent of the sandstone in the southern part of the area.

The *topography* of the sandstone area is quite different from that of the Barron quartzite. It occupies a plain of less relief and lower elevation than the quartzite upland which lies to the east and north. To a greater extent than in the quartzite area

the surface irregularities are due to the glacial drift. Where the drift is relatively thin, as in the area between Canton and Bruce, the sandstone is a more important factor in the topography than it is where the drift is thicker. Elevations of the top of the sandstone in this part of the area vary by more than 100 feet and have a decided effect on the topography. In the large sandstone area on the west there are few wells deep enough to reach the ledge, so practically nothing is known about the relations of the topography to the surface of the sandstone.

The *character* of the sandstone is somewhat variable. The outcrop on the Flambeau River in T. 34-7W. is a rather coarse quartz sandstone with fairly numerous  $\frac{1}{4}$  inch quartz pebbles. It is cross-bedded throughout and more or less stained with iron to a dull brick color. The predominant color is a cream white. It is fairly well cemented sandstone, but is not so solid as the sandstone phases of the Barron. The formation here has a dip of  $10^{\circ}$  to the southwest. No fossils were found.

In the valley of Elder Creek at Atlanta, T. 35-7W., are horizontal beds of yellow to light brown, well cemented sandstone. Some loose pieces of fine quartz pebble conglomerate were found but none in place. It contains a moderate amount of white kaolin powder between the grains of quartz which make up the rock. No fossils were found here.

The various outcrops in T. 34-10W., are very soft, almost uncemented sands, light yellow to white in color, and in several places contain thin partings of light blue clay. Numerous fossils were collected and sent to Mr. E. O. Ulrich of the U. S. Geological Survey to be used in his report on the stratigraphy of the state.

The sandstone found in the wells in this southern part of the area is all described as soft and white to light yellow.

Farther north there is much less information. The well in section 3, T. 38-11W., is in soft, cream-colored sandstone. In T. 38-12W., white sandstone is found in a well. In section 28, T. 39-13W., a well is reported in hard red sandstone. The angular blocks found on the east side of Grindstone Lake in T. 40-8W., are fairly hard red sandstone.

A well is being drilled for the city of Hayward by the Union Machine Co. of St. Paul, who have very courteously supplied samples of the material found. They reported about 70 feet of unconsolidated glacial material, below which they found fine-grained sandstone. The upper 10 feet of rock contains much magnetite and numerous grains of

trap rock. The next 4 feet is fine white sandstone with  $\frac{1}{4}$  inch fragments of lime cemented sand grains. For 63 feet below this there is a very fine-grained sandstone with much fine, red, argillaceous material between the grains. The latest sample shows the material for 53 feet below this to a total depth of 200 feet. This lowest material is coarser, white to faint gray, well rounded sand.

All of the sandstone contains a small amount of magnetite. No quartzite chips and very little material is found other than well rounded quartz grains. From these facts it is believed that the material is Cambrian sandstone rather than the Barron formation.

*Structure.*—The sandstone is seen in so few outcrops that the details of structure cannot be determined. It is essentially flat-lying wherever it outcrops.

The base of the sandstone is not known definitely since no wells have been reported which go through it into the underlying rocks, but it is believed to be at an elevation of about 1000 feet above sea level near Atlanta and Canton.

The soft white and yellow sandstone in the railroad cut about a mile and a half northeast of Canton is found as high as 1170 feet above sea level. If the belief is correct, that the base is at an elevation of 1000 feet, there is present here a thickness of 170 feet.

Just west of Birchwood the sandstone is found in wells at about 1070 feet above sea level and how much lower it goes is not known. In section 3, T. 38-11W., the top of the sandstone is found in a well at an elevation of about 1170 feet. It was penetrated only 8 feet by the drill.

At Hayward the top of the sandstone is found at an elevation of 1110 feet and the drill had penetrated it to a depth of 130 feet when last reported, showing the base to be less than 980 feet above sea level.

The present slope of the surface on which this sandstone was deposited is apparently westward or somewhat south of west from a line drawn south from Hayward, and southward—possibly somewhat west of south—for the area between Canton and Lady-smith. The general slope of the pre-Cambrian surface from Atlanta to Chippewa Falls is about 5 feet per mile. The slope of the westward portion is not known, but at Stillwater, 90 miles southwest from Hayward, the base of the Cambrian is about 100 feet above sea level. This gives a difference in elevation in the base of the Cambrian of about 900 feet, or a slope of 10 feet per mile. This is probably complicated by faulting so that the actual

slope is different from that stated. Whether greater or less is not known to the writer.

The base of the Cambrian is much lower and tilted at a lower angle than the very flat peneplain at the base of the Barron quartzite in the vicinity of Atlanta and Murry, described on pages 42 and 43.

*Relations to Other Formations.*—The base of the sandstone was not found, and no contacts with older rocks are known except for the small amount of sandstone believed to belong to this formation on the Barron quartzite breccia-conglomerate in T. 34-10W., mentioned on page 43. Its relations to this quartzite are such, however, as to make it certain that the sandstone is younger and originally covered the quartzite to a greater or less extent.

As shown by the fossils, the sandstone in T. 34-10W., is Cambrian in age. That all the sandstone mapped to the east, and that shown in the wells in the vicinity of Birchwood, and in T. 38-11 and 12W., is probably Cambrian, is indicated by the soft, unconsolidated character and white color. The hard red sandstone found in section 28, T. 39-13W., and that shown in loose angular blocks on the east side of Grindstone Lake in T. 40-8W., may be the poorly cemented phase of the Barron quartzite and so be Upper Keweenaw in age, but definite proof of this is lacking and the sandstone may all be Cambrian. The character of the sandstone in the well at Hayward indicates that it is Cambrian.

### THE BARRON QUARTZITE

This formation is distributed over a large territory. It is found in townships from 34 to 39 north, in ranges 6 to 12 west. The area in which it is found is best appreciated from an inspection of the map, plate I. At the south three small outliers are indicated near Canton. At the north are shown four large ones south and east of Lac Court Oreilles, and two small ones, the first 4 miles west and the other 8 miles east of Trego. Undoubtedly more of these isolated areas would be found if the thick drift did not obscure them.

The extent of the main body of the quartzite is indicated fairly distinctly by numerous outcrops, talus slopes, topography, and the presence of angular quartzite bowlders in the drift. The northeastern outlier—near Couderay—is mapped entirely on the basis of topography and drift, except for the outcrops in T. 39-6W. The three large outliers west of this show no outcrops whatever.

The elevated topography and the sharply angular, quartzite fragments in the drift indicate the character of the rock quite satisfactorily but the boundaries cannot be determined exactly. It is possible that these four areas are connected with the main area but it is believed that the valleys between them have been cut through the quartzite and leave them as outliers. The two small outliers east and west of Trego are believed to be entirely disconnected from the main body of the formation, but this cannot be stated positively until wells or other borings give more information about the underlying rocks of the intervening area.

From the abundance of angular bowlders of this quartzite in the terminal moraines west and north of Spooner it is certain that the formation occurs to the northwest—outside of the area covered by this report. No outcrops have ever been reported from this direction and it is quite probable that the rock is entirely obscured by the drift. A 400-foot well a few miles northwest of Trego was reported to be bottomed in conglomerate. From the description given this is much like that in section 12, T. 39-11W.

*Outcrops* of this formation are shown on the township maps. They are quite common along the southern, eastern, and northern side of the main body and in the southern outliers, and scattered outcrops are found through the central part. Beside these there are three small areas in which the quartzite outcrops—the northwest corner of T. 39-6W., the northeast corner of T. 39-11W., and the northwest corner of T. 39-12W.

*Topography.*—This formation expresses itself as a high rolling upland, with marked relief. The elevation at which quartzite is found vary from 1100 to 1770 feet above sea level. The highest point west of Range 7E, whose elevation was measured during this work lies in this quartzite area in T. 37-8W. This is only 170 feet lower than Rib Hill, south of Wausau, the highest measured elevation in the state.

By referring to the general map, plate I, it will be seen that the streams flow away from the quartzite on all sides and that no stream crosses from one side to the other of the main body. The rather abrupt rise from the surrounding lowland to the quartzite is well shown by the profiles on the following township maps: T. 34-9W., T. 35-10W., T. 36-7W., T. 37-7, 8 and 9W., T. 38-8W., and T. 39-8W. This last map shows the elevation of the two large northeastern outliers and the depression between them in which lie Devils Lake and its outlet. Couderay River and one of



its minor tributaries occupy the valleys between the main mass and the two large outliers in T. 39-8 and 9W., and T. 38-8 and 9W.

Other outliers probably exist which are not indicated by drift boulders, and are masked by heavy terminal moraine deposits. It is also probable that the main mass of the formation was cut across by the pre-glacial drainage in several places, as numerous large gorges are found either with no drainage or occupied by streamlets wholly inadequate to have played any noteworthy part in carving the valleys in which they flow.

*Character.*—This formation is quite variable. It is usually fine-grained, the average size being about .008 of an inch in diameter, but many local phases show numerous fine stringers and scattered grains ranging up to .04 of an inch in diameter. More unusual phases show small pebbles of vein quartz  $\frac{1}{4}$  inch in diameter and rarely (and in the basal portions only) thin stringers of conglomerate with 1 inch pebbles—chiefly of quartz, but with occasional quartzite, slate and iron formation fragments. The grains are almost wholly quartz and the cement is silica. The basal portion, where the contact with underlying rocks is found, occasionally contains fairly large percentages of decomposed schist or slate in the form of red argillaceous material. Throughout the formation it is not uncommon to find between the quartz grains minute quantities of earthy powder that appears to be white kaolin.

A very minor phase of this formation, which, however, is widely famed because of its use by the Indians, is the pipe stone, or catlinite which occurs in thin shaly beds in the quartzite. It is found in comparatively few places and nearly all these localities are near the southwest end of the main body of the formation. It was found in the north part of section 30, T. 35-9W., interbedded with the quartzite. "The renowned Indian quarry\* is located in the S. E.  $\frac{1}{4}$  of the S. E.  $\frac{1}{4}$  of section 27, T. 35-10W. The pipestone here is very dark red, soft, sometimes ripple-marked, seamed and banded with light colored quartzite. This stone also graduates into a siliceous, schistose rock unfit for pipes. At the quarry, which occupies the summit of a hill, the Indians have broken up the surface layers over an area of about twenty-five feet square, but nowhere have they dug more than three feet below the surface; so that the quarry is rather one of renown than of extension. The upper layers are the more schistose, the interior beds being less so and softer. The catlinite is easily and successfully wrought when fresh, but hardens somewhat on exposure to the air.

\*Chamberlin, T. C., Geol. of Wisconsin, Vol. IV, page 578.

“In the S. E.  $\frac{1}{4}$  of section 25, T. 35-10W., is a very dark red, siliceous rock, somewhat harder than the pipestone (hardness about 2.50), but quarries in large regular pieces often three or four feet in length, and one to six inches in thickness. Its surfaces are beautifully ripple-marked. It seems to have a constitution closely similar to the pipestone, but is harder and contains very small scales of white mica. It would form a very handsome building stone. Its entire thickness was not exposed. It is underlain by the usual quartzite.”

Thin stringers of pipestone  $\frac{1}{4}$  to 1 inch in thickness are found in a number of places. Closely allied to these are the rather common mud flakes which are often preserved with beautiful sharpness. One flake 6 inches in diameter and about 1-8 inch thick was found in section 19, T. 38-8W. In this locality the mud flakes are very plentiful and show many surprisingly regular shapes. They are so thin and so uniform in size and shape it was thought possible that they might be fossils. While some are undoubtedly mud flakes, it is believed that search by a paleontologist would be well repaid by the finding of unquestionably organic forms.

The three main phases of the quartzite are the purplish pink, well cemented quartzite, the yellowish somewhat less well cemented quartzite, and the striped or stain-banded phase.

The *color* is predominantly a flesh pink. This grades to purplish pink on the one hand and on the other to white or gray, and flesh color or sandy yellow. A very prominent phase is a very light colored rock stained by iron in narrow bands that range from faint pink to dark red. These stained bands quite frequently follow bedding but in many cases they cut across it at various angles. Often the bands assume various contortions simulating folding and cross-bedding, making it very difficult to tell the attitude of the real bedding. This phase is found in many places at various horizons in the formation but is best developed in the canyon of Sucker Creek in the southeast corner of T. 37-9W.

The *bedding* is usually well marked and the beds are thin—seldom more than a few inches thick. Cross-bedding is found in a few places. Ripple marks are found rather infrequently. In two places—section 35; T. 37-9W., and section 19, T. 38-8W.—very unusual ripple marks are found which are only about one inch from crest to crest. The conditions under which such small ripple marks were formed are not understood. Ordinary ripple marks, both in ancient quartzites and on the sandy shores of modern



A. RAILROAD-CUT IN BARRON QUARTZITE IN SECTION 21,  
T. 38-8W.  
The rock shows the gentle dip and shattered condition characteristic of this quartzite.

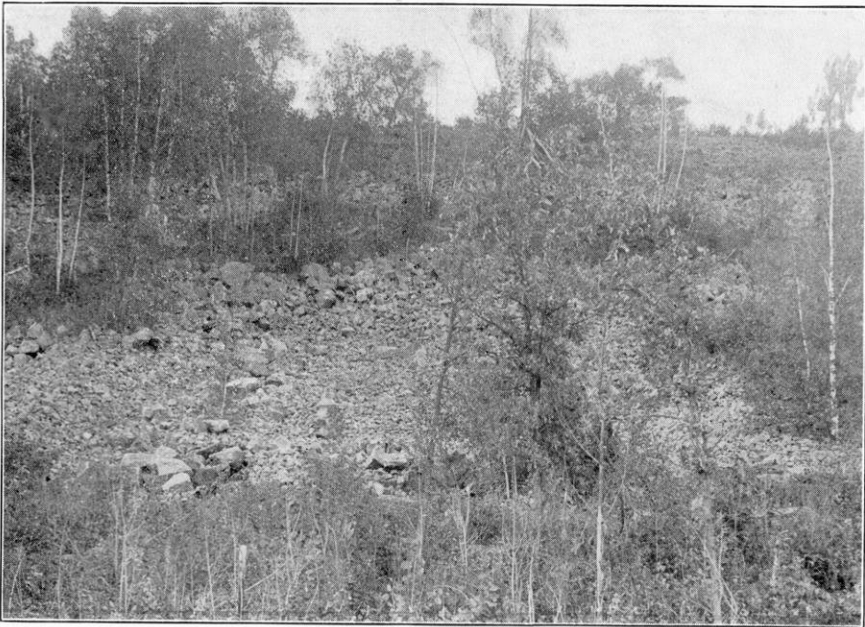

B. TYPICAL TALUS SLOPE OF THE BARRON QUARTZITE.



lakes are about 2 to 3 inches from crest to crest. It is suggested that these small ones may possibly have been formed in broad sheets of water only a few inches in depth, but whatever the origin they indicate somewhat unusual conditions at the time they were formed.

The *jointing* of the formation is very pronounced. It is very much fractured so that its usual manifestation is not in outcropping ledges but as masses of small angular talus blocks a few inches to two feet, rarely three feet, in diameter and seldom over a foot thick. These talus slopes frequently cover the whole ledge so that no rock in place is to be found. Such a slope is shown in A, plate IV, and the broken character of the ledge rock is shown in B of the same plate. Low flat ledges are often seen in which the surface is almost entirely covered with a loose mass of angular blocks barely turned from their original positions. Precipitous cliffs of quartzite are found in a few places along the eastern border of the main area but very few reach a height of 40 or 50 feet. The highest cliffs found are in section 13, T. 36-9W., where the canyon walls are 75 feet high.

*Folding* and *faulting* are quite mild in character. No dips greater than  $25^{\circ}$  are found in the main area of the formation, and in most of the outcrops the beds dip about 5 to  $12^{\circ}$ . The two outliers east and west of Trego, and some of the outcrops in T. 39-6W., have steeper dips. These are described separately on pages 41 and 42. Faults with indications of slight movement were found in the south side of section 6, T. 38-8W., and near the southeast corner of section 21 of the same township. The movement in both cases seems to have been mainly horizontal. Some of the numerous small canyons in the main quartzite area may mark the courses of faults but no proof of this was found. Since the formation is believed to be about 600 feet thick, and uniform dips of  $10^{\circ}$  to  $15^{\circ}$  would carry this thickness below the level of the country in less than a mile, it is believed that there has been more or less elevation of blocks down the dip by faulting so that the formation is repeated. The characteristic broken nature of the formation is believed to be due to this, at least in part. It is probable also that initial dip aids in giving to the formation the appearance of a greater thickness than is believed to exist.

The *metamorphism* of this formation is exceedingly interesting. It was originally deposited as a sand on a broad flat area over which the water was probably very shallow. Since that time

it has been cemented, almost entirely by silica, so that parts of it are sandstone and other parts are vitreous quartzite. Large parts of it have been stained by iron, either in narrow, parallel straight bands, or in fantastically curved and contorted patterns. The iron staining very rarely is sufficient in amount to have an appreciable effect as a cementing material.

The cementing of the constituent grains by the deposition of silica from solution has gone on with an irregularity difficult to understand. This lack of regularity is undoubtedly only apparent, for if more were known of the conditions which determine whether or not a particular sand is to be cemented to a quartzite there would unquestionably appear good reasons for the irregularities in this case. In section 20, T. 35-8W., a thickness of several feet at the base of the formation is soft sandstone. Above this the formation is quartzitic and when the rock is fractured the break goes across most of the grains rather than around them.

In section 33, T. 35-9W., the cementing of the formation has been much more irregular. In some places the contact between the well cemented and the poorly cemented parts (the quartzite and sandstone phases) is a bedding plane. At other places,—and these are more common—the same bed is quartzite in one place and sandstone a few inches away. In such cases the two phases are often separated by a heavily iron-stained band  $\frac{1}{8}$  to 2 inches wide. The weathering of the two phases in the cliff face is markedly dissimilar. The sandstone phase is wind eroded along bedding planes so that the beds were rounded on their exterior. The quartzite phase is untouched by wind erosion and the projecting corners are sharply angular, as shown in B, plate V. Figure A in plate V. shows a view of cliff of the sandstone phase. On breaking a piece of the quartzite it is usually found that while the fracture has gone through a large part of the grains, a fair percentage have not been broken and so show their original rounded form. Examination with the microscope shows numerous places where the space between the grains has not been completely filled, even in the more thoroughly cemented phases.

Because of the badly fractured nature of the formation it is believed that it was folded when there was little or no weight upon it. There is no place where curving of the beds is shown that they are not badly shattered, and no evidence was found to indicate that the formation was anywhere buried deeply enough to yield by rock flowage during the slight amount of deformation to which it has been subjected.

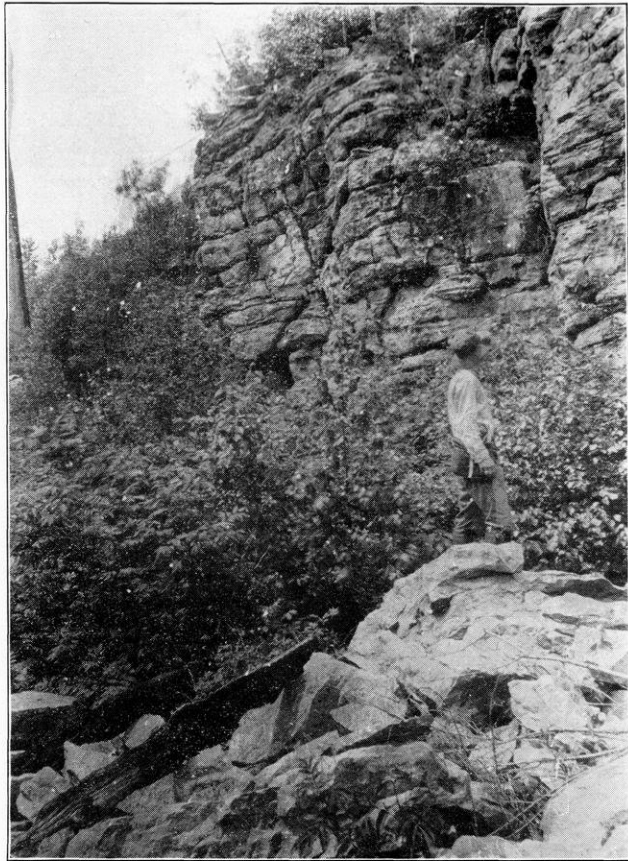

A. CLIFF OF BARRON QUARTZITE IN SECTION 33,  
T. 35-9W.

Shows rounded wind-eroded forms characteristic of the sandstone phase.



B. CLIFF OF BARRON QUARTZITE WITH TALUS SLOPE  
AT BASE.

Shows angularity of broken beds of the vitreous quartzite phase on which wind erosion has had no effect. This cliff is within 100 feet of the sandstone phase shown at the left, and in the same beds.





*Outcrop in Section 31, T. 34-10W.* About two hundred feet from the road in the S. E.  $\frac{1}{4}$  of the N. E.  $\frac{1}{4}$  of the section is a very interesting outcrop. It is made up of angular to slightly rounded blocks of quartzite with the spaces between filled with sand which also has been cemented to quartzite. The whole mass was later jointed and one of the joints shows a filling of softer Cambrian sandstone. The blocks are pink and striped quartzite, exactly like the typical phases of the Barron.

The outcrop is evidently a remnant of an old quartzite talus slope into which sand was washed to fill the spaces and later itself cemented to a quartzite. This matrix quartzite is yellow and somewhat lighter in color than the fragments it encloses. Compare this with the conglomerate described in the following paragraphs.

*Outcrop in Sec. 12, T. 39-11W.*—The quartzite is found here in an isolated rounded hill projecting above a plain. On the north-east side of the hill the rock is a salmon pink quartzite. In no particular noticed was it unlike the quartzite in the main area of Barron formation. The dip here is  $15^\circ$  northward and the strike N.  $85^\circ$  E. Going southward around the east end of the hill the angle of the dip increases to  $40^\circ$  or  $50^\circ$  with a strike N.  $45^\circ$  E. On the south side of the hill is found a great bed of conglomerate with a thickness of 40 to 50 feet exposed and neither upper nor lower limits showing. This conglomerate dips  $60^\circ$  to the north-west and the strike is N.  $40^\circ$  E. The pebbles composing it are almost perfectly rounded and vary in size from 1 to 8 inches with a few somewhat larger. The predominant size is about 4 inches. They are somewhat flattened ovoid in form and very few show any flat sides or concave surfaces. The greater part of the pebbles are a salmon pink quartzite. Some of them are of the faintly stain banded phase, and many of them are of the yellow flesh colored phase. There are a very few vein quartz pebbles found—not over  $1\frac{1}{4}$  inches in diameter—and no other varieties.

The matrix is ground up quartzite sand, more yellowish in color than the majority of the pebbles. This indicates that the quartzite formation from which the conglomerate was derived had yellow softer phases and red and pink hard phases which chiefly formed matrix and pebbles respectively.

The pebbles were evidently rounded after being cemented to quartzite. The matrix has been recemented quite thoroughly so it is again a quartzite.

The whole mass is badly shattered, even small pebbles being broken into several pieces. This is believed to indicate that the

folding was accomplished under comparatively slight load, or in other words, that the formation was not deeply buried by other rocks while it was being folded.

*Outcrop in Sec. 6, T. 39-12W.*—This outcrop is a low mound 5 or 6 feet above its surroundings. An excavation about 35 feet long and 20 wide has been made in the quartzite. The rock varies from dark brownish red to light reddish yellow in color. It is a fine-grained, well cemented phase of the quartzite. No bedding was distinguished with certainty but after careful search the best evidence seemed to point to a dip of  $50^{\circ}$  N. E. and the strike about N.  $70^{\circ}$  W. It is badly fractured. The best developed joints are nearly vertical and strike at right angles to what was taken as the direction of the bedding. Quartzite was found in a cellar bottom near the outcrop and in a well a short distance to the south. The soil for some distance is full of angular quartzite, indicating that this formation is close to the surface over a fairly large area. The angular blocks in the soil show all the phases of the typical Barron, from the hard, dark quartzite, like that seen in the outcrop, to the softer yellow and the stain banded phases. Even the somewhat unusual phase showing mud-flakes was found.

There is an abundance of angular blocks of this quartzite in the moraine a mile north of the outcrop. This moraine marks the terminus of a small lobe of ice that came from the north. It is found plentifully also in the moraine at Spooner, which came from the west. These facts indicate that this formation extends westward and northward for some distance beyond the area mapped and have an important bearing on the age of the formation, a subject which is discussed later.

*Structure.*—The Barron formation as a whole is very gently folded. Along the south side the direction of dip varies from north to northwest. Around the east side of the main mass the direction of dip is more to the west, and toward the north of the main body the dips are southwest. All dips in the main area are gentle. The elevation above sea level of the base of the formation changes in quite regular fashion. That part near Canton is believed to have its base at an elevation of about 1100 feet. Southeast of Birchwood quartzite is found at an elevation estimated to be slightly less than 1100 feet. The contact is not exposed but it is believed that this is near the base of the formation. In the north part of T. 34-9W., the base is at an elevation of about 1380 feet. West of Murry (T. 36-7W.) the base is at an elevation of about 1320 feet.

In the east side of T. 37-8W., it is about 1380 feet. Near the center of T. 38-9W., it is about 1280 feet.

From these observations it appears that the main area is the east side of a gentle saucer-shaped depression, the base of which is at quite uniform elevation along the east sides and is lower at the west. It is believed that the direction of dip along the west side of the main area is horizontal or to the east, but no ledges are exposed here on account of the heavy drift and the heavy covering of vegetation usually found on the northwest sides of elevations.

In T. 39 and 40-6W., there are outcrops which form a westward pitching syncline. The north side dips steeply to the south and the south side dips very gently to the north. From the topography to the southwest it is believed that this syncline flattens out in this direction.

The outcrops found east and west of Trego also have fairly steep dips— $50^{\circ}$  to  $60^{\circ}$ —in a northward direction. So far as evidence was found these are probably monoclinical remnants.

*Thickness.*—If the dip and horizontal extent were used as the only factors to estimate the thickness of this formation it would be necessary to give it a thickness of many thousand feet. The topography of the formation indicates, however, that this estimate of great thickness is not correct. Wherever found the quartzite appears as a capping for the hills. The best evidence of thickness is believed to be the difference in elevation between the base and the tops of the highest hills, and the nearly continuous exposure in sections 16 and 17, T. 38-8W. These agree in giving a thickness of about 600 feet. This estimate is also sufficient to account for the probable thickness in T. 39-6W. It is interesting to note that the thickness of this quartzite is sufficient to obscure entirely the mild magnetic attractions which are traced up to its eastern edge.

*Relations to Other Formations.*—This formation is not known to be overlain by any other at present, but at least part of it was undoubtedly covered at one time by the Upper Cambrian sandstone. What was believed to be this sandstone was found upon the quartzite in a tiny patch and filling a joint crack in the breccia conglomerate described on page 41.

The plain at the base of the quartzite is tilted more than that at the base of the sandstone, and it is also at a considerably greater elevation, proving that the Cambrian lies upon an erosion surface.

formed long after the deposition of the quartzite. These facts afford conclusive evidence that the Barron quartzite is older than the Upper Cambrian.

The quartzite lies over and is younger than the formations found to the east of it. These formations were badly weathered and levelled off by erosion to an unusually flat surface before the quartzite was laid down. Several exposures of this contact are found in T. 36-7W. and T. 35-8W. Wherever found the contact is sharp and the older formations were bevelled off so completely as to yield almost no debris to the quartzite. A few quartz pebbles or an occasional small fragment of slate are found in the first three or four feet of the quartzite, but the usual relation is a fine quartz sand or quartzite lying with no transition beds upon the upturned eroded edges of the older rocks. The almost perfect base levelling of these beds corresponds with the large amount of erosion of older beds described at the base of the Keweenawan in the Gogebic range and elsewhere.

The relation of the Barron quartzite to the Keweenawan traps is not definitely given by exposed contact. Weidman\* found evidence that the quartzite is intruded by a small basic dike in section 21, T. 38-8W. He also found evidence that led him to believe it is intruded by a basic dike found in the pits in section 14, T. 35-10W. It is possible that in this last location the igneous rock is unconformably below, as the pits are near what is believed to be the western edge of the quartzite.

The only outcrop of the quartzite near the main body of Keweenawan traps is that in section 6, T. 39-12W. The magnetic attractions indicate that the trap occupies the area immediately to the southwest, and the quartzite apparently dips to the northeast. These facts are not determinative of the relations of the two, but in conjunction with the evidence found in the glacial drift are believed to be significant. The moraine at Spooner, which came from the westward, contains much angular quartzite showing all the phases of the main area of typical Barron quartzite. The same is true of the moraine found in the township just north of the outcrop. This moraine came from the north. These facts indicate strongly that the Barron quartzite is found to the westward and northward overlying the northwestward dipping trap flows. If this is true the Barron quartzite must be correlated with the Upper Keweenawan.

\*Unpublished field notes. Wis. Geol. Survey.

The intrusives mentioned would in that case be later than the main period of Keweenawan igneous activity, and the relation of the quartzite to the older rocks would be due to overlap.

The conglomerate described on page 41 and the breccia described on page 41 are strong but inconclusive evidence that in this area mapped as Barron formation two unconformable quartzites are found. In both cases the facts found show that the older formation was cemented to a quartzite before the period of erosion which resulted in the formation of the conglomerates and the second quartzite. The development of a thickness of 40 to 50 feet or more of such perfectly rounded conglomerate as that described would appear to demand an erosion interval of some importance. This conglomerate is made up of material typical of the Barron quartzite between Canton and Beverly, which is believed to be younger than the Keweenawan traps. This gives some basis for the recognition of an unconformity of considerable magnitude in the Upper Keweenawan, or it may be interpreted as intraformational like other Keweenawan conglomerates.

While the exposures are too few to permit the statement of this correlation and the consequent subdivision of the Upper Keweenawan more positively than as a probability, the facts at hand do not at present seem to permit of any other conclusion.

Another possible interpretation of these conglomerates would be to correlate them with the Upper Keweenawan and the quartzite below with the Lower Keweenawan. While this must be admitted as a possibility the notable lithologic identity, in all phases, of the quartzite between Canton and Beverly and that north and west of Spooner, is too strong evidence that the main area of quartzite is not Lower Keweenawan to make this suggested correction seem at all probable.

#### HURONIAN FORMATIONS

*Distribution.*—The areas in which Huronian rocks are present are scattered widely over the district east of the sandstone and the Barron quartzite. They are irregular in shape but exhibit a decided general trend somewhat north of east. East of Range 9W. there are only three townships—41, 42 and 43N.-2W—in which it is believed that Huronian rocks are not present, and in none of these three can their absence be stated unequivocally. The distribution is indicated on the map, plate I.

It is advisable at this time to depart from the regular order of description of these formations in order to secure a clear general picture of the conditions, and so be able to appreciate both the weakness and the strength of the evidence upon which these areas are shown to include Huronian sediments.

The character of the surface before the glacial period, the manner in which the glacial materials were deposited, and the erosion by the streams since the glacial period are the three essential elements of the picture that should be clearly in mind.

The character of the surface before the glacial period can be compared roughly to that of the Marquette range at present. In this range there are long, narrow depressions occupied by the Huronian slates and iron formations. These depressions lie between ridges of more resistant Huronian quartzites and dolomites. To the north and south are higher areas of older rocks, granites, gneisses and schists, of a character somewhat more resistant than the average of the Huronian rocks. This brief outline of the topography of the rock surface will apply in a general way to all pre-Cambrian areas. The granites, gneisses, and hornblende schists are commonly found in rather large masses. They are invariably more resistant than the average of the Huronian rocks and so the areas underlain by them are higher than the areas underlain by Huronian rocks. The only exception to this general statement is the Huronian quartzite, which is more resistant to erosion than granite and so is often found in hills higher than the granite areas. But quartzite is not always present in the Huronian series in sufficient thickness to have a marked topographic effect.

The form of the rock surface in this area was the result of millions of years of erosion, during which the streams in the less resistant rocks, such as the Huronian slates and iron formations, were able to cut their valleys deeper than the streams flowing on granite and gneiss. As a consequence the main valleys were located in the Huronian slate areas and the valleys in the more resistant rocks were tributary to them. This relation of drainage to Huronian slate areas has persisted through the glacial period to the present time in regions where the drift is not too thick. The main streams of northern Michigan follow in a general way the old pre-glacial valleys in the Huronian slates.

From the foregoing statements it is evident that the general elevation of the surface of the Huronian slates and iron formations

should properly be expected to be lower than the elevation of the areas of granite and gneiss. A general idea of the rock surface is given in the cross-section, figure 3.

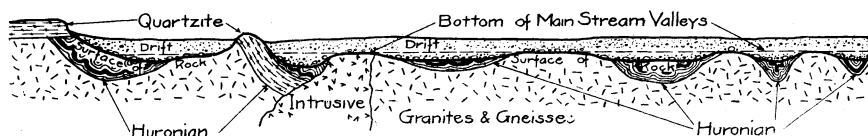

Fig. 3. Hypothetical cross-section showing the relations of the various rock formations and the reason why the outcrops are mostly granite and gneiss.

The second essential element of the general picture of conditions is the manner in which the glacial materials were deposited upon this rock surface. The general advance or retreat of the glaciers was by a series of oscillations or minor advances and retreats. During a general advance the minor advances predominated over the minor retreats. During a general retreat the reverse was the case. As the ice advanced its movement was retarded by elevations and relatively accelerated by depressions so that its edge was a series of small lobes in the valleys with re-entrants marking the divides. The constant melting produced streams which found their way down the existing valleys. The great amount of loose debris furnished by the glacier was more than the streams could carry so they gradually filled their valleys with it. After the glacier advanced over this valley fill and over the divides between the valleys, it melted back and left its load of boulders and clay and sand in more or less irregular hummocks and sags. As it melted back the streams deposited more material in the valleys to be covered by the drift of the next advance of the ice and so on. Thus the deposits were built up, the thickest deposits largely as valley filling, and later, as the valleys were filled to the brim, as a general drift deposit over the whole country. At the position of greatest advance the minor advances and retreats probably continued in nearly even balance for a relatively long period before melting gained the ascendancy over advance and caused the general retreat. As a result of these processes the thickness of drift near the edge of the Wisconsin ice sheet is very great and very few ledges of rock are left uncovered by drift.

The area shown on the map—plate I—is close to the edge of the Wisconsin ice sheet, so it differs from much of northern Michigan in having a somewhat deeper cover of drift and fewer rock outcrops. This second element in the general picture of conditions

explains why practically all rocks, in both high and low areas are deeply covered with drift except in the extraordinarily high quartzite hills.

The third essential element in the picture of conditions is the erosion accomplished by the streams since the glacial period. After the glaciers retreated the streams began to carve their valleys deeper. The drainage courses were frequently quite different from those preceding the glacial period. In many cases the streams were at right angles to the pre-glacial valleys. In cutting their valleys deeper some of the streams have cut into rock which formed the divides of the pre-glacial drainage. As may be seen best from figure 3, the first rock to be exposed was the granite and gneiss forming the more elevated portions of the rock surface. In this section the dashed line indicating the bottom of the main stream valleys is shown level with the tops of the granite and gneiss areas.

The third element in the general picture of conditions concludes the explanation of why, in an area where the only rock outcrops are granites, gneisses, and hornblende schists, it can be so confidently held that the presence of large areas of Huronian sediments is not only possible but a practical certainty. The old idea that Northern Wisconsin was a great area of granite and gneiss arose from the fact that these are practically the only rocks outcropping. The facts given here showing that the areas between, in which there are no outcrops, are Huronian have not been appreciated up to the present time.

With this general picture in mind the other lines of evidence which go to prove that Huronian sediments are widely distributed in this area can be considered with profit.

As stated in the introductory part of this chapter magnetic observations are the chief basis for the mapping of these areas as Huronian. Without these magnetic observations it would be necessary to map the areas showing granite outcrops and include all the remainder as possibly containing Huronian sediments. With these observations it can be stated with practical certainty that the lands in Class C1 are underlain by Huronian rocks, but as exposures are lacking it is impossible to be absolutely certain.

There are three cogent arguments which thoroughly warrant the interpretation that certain of the magnetic attractions indicate the presence of Huronian sediments, and, more particularly, Huronian iron formations. These are first, the general close association of magnetic lines and Huronian iron formations in northern Michigan



and in the Florence and Gogebic districts in Wisconsin—this whole region being continuous, and, so far as known, exhibiting general similarity of geologic conditions; second, the great abundance of iron formation pebbles and bowlders in the glacial drift, as shown by the drift analyses given on pages 63 to 74; and third, the discovery of iron formations and other Huronian sediments by drilling along similar magnetic lines in northern Vilas county, and just across the state line in Michigan.\*

These several lines of evidence justify the policy of mapping the areas containing Huronian sediments and iron formation. An inspection of the general map, plate I, will disclose the fact that in many cases areas of abnormal magnetic attraction are found in territory shown to be underlain by granites and gneisses, and by Keweenaw trap rocks. By studying the detailed observations shown on the township plats it will be seen that the magnetic attractions in these igneous areas exhibit characteristics decidedly different from those due to Huronian rocks.

*Character, Structure, and Relations to Other Formations.*—Outcrops of Huronian rocks are found only in Flambeau Ridge—T. 32-7W.; in T. 33-7W.; along the railroad in T. 34-8W; in T. 35-8W.; and in T. 38-5E; and outcrops possibly of Huronian age in T. 36-10, 11 and 12E.; in T. 39-1 and 2E.; and in T. 40-4W. From this it is evident that but little can be said about the general character, structure and relations to other formations. Such facts as are known are given in the township descriptions. From the information given by these outcrops and the drilling near the state boundary in Vilas county, the conclusion can be drawn that the Huronian rocks are largely slates, with iron formation, some quartzite and dolomite beds of minor importance, and some volcanic rocks. The indications of structure suggest rather close folding and steeply inclined beds. The strike is northeast—parallel to the general direction of the Huronian rocks in Minnesota and in the Gogebic range.

The steep dips, the soft schistose character of the outcrops in T. 35-8W., and the apparent lack of quartzite in most of the Huronian areas suggest that the character and structure of the formations and the manner of occurrence of the iron formation probably resemble most closely the conditions found in the Cuyuna range.

The relations to other formations are undoubtedly the same as in better known Huronian areas. Most of the granite, gneiss and

\*Allen, R. C., State Geologist of Michigan. Unpublished manuscript.

hornblende schist is unquestionably older and unconformably below the Huronian, but it is also practically certain that some igneous rocks intrude the Huronian sediments. How extensive these intrusives may be is unknown, but the general character of magnetic attractions suggests that intrusives may have been more important in the eastern part of the area.

Huronian slates are found in nearly vertical beds with the Barron quartzite lying horizontally across the eroded edges. This relation is adequate proof that these slates are older and unconformably below the Barron quartzite.

It is not possible from the information available to state what particular Huronian series are present in this area, except that either the Upper or Middle, which contain iron formation, are certainly represented. It would be somewhat surprising if, in such a large Huronian area, all three series were not found.

The only Huronian formation sufficiently well exposed to give an adequate idea of its character and structure is the Flambeau quartzite. This is described in detail in the succeeding pages. The other exposures of Huronian rocks are chiefly isolated outcrops, and the facts observed are given in the township descriptions.

### *Flambeau Quartzite*

This formation occupies the northern part of township 32-7W., and extends into section 6 of the township east.

*Outcrops.*—These are found only in section 6, T. 32-6W., and in sections 1, 2, 11 and 12 of T. 32-7W.

*Topography.*—The formation occurs in a great ridge which rises to a height of about 450 feet above the Chippewa River and is visible for many miles. The road across the eastern end of the ridge rises to an elevation of 1350 feet above sea level, and the summit of the ridge is estimated to be approximately 150 feet higher. The elevation of the river at the mouth of the Flambeau is 1050 feet. The area comprising the east half of section 1 and the west half of section 6 is occupied by a rounded hill of quartzite separated from the main ridge by a pronounced valley which probably marks an old channel of the Chippewa. A view of the ridge from the north showing this old valley is given in plate VIII. From the northeast corner of section 11 a valley leads up to the center of the southwest quarter of section 2. This valley has outcrops of quartzite north and south of it and suggests the presence of more easily

eroded beds, possibly slate, at this horizon. The occurrence of 2 to 4 inch fragments of ferruginous slate in the quartzite to the north also bears out this suggestion.

*Character.*—In composition the quartzite is chiefly quartz grains, usually varying in size up to .01 inch and averaging about .004 inch. In some parts there is a very small percentage of feldspar grains. As a rule the rock is quite well cemented and is vitreous, but the interstices are not completely filled. In section 1 some of the uppermost beds are so poorly cemented that they could be described as a very well cemented sandstone. The individual grains are somewhat more distinct than those of the Baraboo quartzite and decidedly better cemented than those of the Barron quartzite as a whole, although many parts of the Barron are better cemented than this softer phase. The cement is silica.

The lowest quartzite beds seen are marked by thin beds of conglomerate in a number of places. In section 11 these conglomerate layers are not over three or four feet thick as a rule and are composed of pebbles up to  $2\frac{1}{2}$  inches in diameter. The pebbles are dominantly vein quartz, but there are numerous pebbles of quartz porphyry and dense, oolitic, red jasper. A few red slate fragments, granite and red quartzite pebbles are also to be noted. Conglomeratic layers are found also in section 2 and in sections 1 and 6. These conglomerates have the same varieties of pebbles but they are seldom more than  $\frac{1}{2}$  inch in diameter. In sections 1 and 6 the beds of fine conglomerate are 10 to 15 feet thick, and are found through about 40 feet of strata.

The *color* varies from a predominant reddish brown to pale yellowish gray. The *bedding* is somewhat obscure in many places but is sufficiently well marked to give the attitude of the formation beyond question. *Cross bedding* is occasionally found and indicates that the depositing currents came from a southerly direction, and that the top of the main mass of the formation exposed in section 2 and 11 is toward the north. *Ripple marks* are found only in section 6 and are about 2 inches from crest to crest—much larger than some of those in the Barron quartzite.

The quartzite is well jointed. Sweet\* noted joints as follows: vertical, strike S.  $50^{\circ}$ W.; dip  $77^{\circ}$ SW, strike N.  $60^{\circ}$ W.; dip  $37^{\circ}$ S, strike N.  $60^{\circ}$ E. It is usually broken comparatively little, but the outcrop in the northeast corner of section 11 has been broken and recemented by numerous quartz veinlets. The lower beds

\*Geol. of Wis., Vol. IV, page 577.

south of the north quarter post of section 11 also show some quartz veinlets, mostly parallel to the bedding.

*Structure.*—The main ridge is a monocline dipping 75° to 85° to the north and striking nearly east and west. In sections 1 and 6 the strike changes to northeast, north, and then northwest, as it is followed around from the south to the north, showing that the main ridge is undoubtedly the south limb of a syncline, the north limb being absent except for the small part near the quarter post between sections 1 and 6. The dip is much more gentle around the turn at the east—the uppermost beds being tilted about 35°.

*Thickness.*—Sweet\* estimated the entire thickness of this formation to be not far from 5000 feet but it is believed that this estimate is excessive. In section 1 there is about 600 feet of beds in practically continuous exposure. In sections 2 and 11 the size of the ridge and distribution of outcrops indicated a thickness somewhat in excess of 2000 feet, and probably not over 2500 feet.

*Relations to Other Formations.*—No other rocks were found in contact with the Flambeau quartzite. Sweet mentioned outcrops of syenitic granite found in the Chippewa River, 1½ miles east of the outcrops described in section 6. He believed the granite to be older than the quartzite. No new evidence was found on the relations of these rocks, and it is thought that Sweet's conclusion is correct. This formation is believed to be older than the Barron quartzite for three reasons, (1) because it is better cemented, (2) because it has been strongly folded so that its beds are now nearly vertical, and (3) because it is less broken. Since the folding resulted in comparatively little fracturing the formation must have been deeply buried, while the Barron does not present evidence of having been buried by any pre-Cambrian formation.

If this quartzite is older than the Barron it must be Huronian. In general appearance and condition it is similar to most of the Huronian quartzites. However, quartzites are found in all three Huronian series, Lower, Middle, and Upper. The only evidence as to which of these series it may most properly be correlated with is the occurrence of pebbles of iron formation and an older quartzite in the conglomerates near the base. As these pebbles must have come from an older sedimentary series this quartzite is most properly correlated either with the Middle, or Upper Huronian. If this correlation is correct it is probable that the quartzite is one member of a series which would include slate and iron formation, as in other Upper or

\*Ibid. page 576.

Middle Huronian areas. A short and very weak magnetic belt was found a short distance north of the ridge that may indicate something of this sort, but aside from the quartzite no rocks of the series were found outcropping.

#### IGNEOUS AND METAMORPHIC ROCKS

Rocks of these types are widely distributed over the area surveyed. The thick cover of glacial drift makes it impossible to discover their exact distribution, or to tell where sediments begin and these rocks leave off. While the areas shown as igneous and metamorphic rock on the map, plate I, are believed to contain very little sedimentary rock, it is probable that the areas shown as Huronian contain a fairly large percentage of igneous and metamorphic rocks.

Exposures of these rocks are found in the twenty-five townships given in the following list:

33 - 6W	37 - 8W	39 - 1W
35 - 6W	38 - 2E	39 - 6W
35 - 8W	38 - 5E	40 - 1E
36 - 10E	38 - 5W	40 - 1W
36 - 11E	38 - 6W	40 - 4W
36 - 12E	38 - 7W	42 - 5W
36 - 6W	38 - 8W	43 - 2W
36 - 7W	39 - 1E	43 - 5W
36 - 8W	39 - 2E	43 - 6W
37 - 7W	39 - 3E	43 - 7W

The outcrops of igneous and metamorphic rocks are in an area of heavy drift and do not project above the surrounding surface to form hills of any magnitude. Many of the outcrops are in the bottoms of valleys where the streams have carried away the glacial drift that formerly covered them. This is shown in Plate VI. These rocks undoubtedly were important elements in the topography of pre-glacial time, as explained on page 47, but they have been so deeply buried that this effect is no longer evident.

No profitable discussion of the general character and metamorphism of these rocks can be given at this time. The exposures are so few and so widely scattered that there is no means of telling what relation the rocks in one outcrop bear to those in the next, which may be 10 or 20 miles away. All that is possible is to state the conditions found in the individual outcrops and this is done in the descriptions of the separate townships.

The relation of the igneous and metamorphic rocks to the Huronian sediments are known only in a general way, chiefly from evidence found outside this area. The Keweenaw trap rocks occur both as intrusives and as surface flows overlying the Huronian. The granites and gneisses are in large part older than the Huronian, and form the base upon which it was deposited. Some of the granites are probably of later age and intrude both the Huronian sediments and the Keweenaw traps.

It is impossible to state which granites are older and which of the later age, with so little evidence as is presented. It is believed that intrusion has been more common in the eastern part of the district than in the western part, but this belief, it must be admitted, is based on very slight evidence.

The schists are almost certainly of more than one age. Some are probably metamorphosed Huronian slate sediments, others are mashed igneous rocks and possibly volcanic tuffs. The outcrops are too few to give reliable evidence and possibilities are the only statements that can be given. These outcrops are described in the separate township descriptions.

## FACTS WHICH INDICATE THE PRESENCE OF AN IRON FORMATION

In this chapter and in chapters V and VI general statements are given to prove that iron formation is present in this area. Each township description includes a discussion of the local observations indicating the presence or absence of iron formation in that township. In none of these places, however, is there a connected discussion of all the lines of evidence. Only those facts are mentioned which are found locally, or are needed to illustrate the point under discussion. For this reason there is given in the following paragraphs a discussion of the specific facts indicating the local occurrence of an iron formation which are obtainable from a careful geologic study.

Briefly stated, the lines of evidence found in this area are four: 1, actual outcrop—a single outcrop of iron formation found west of Bruce, 2, magnetic attractions, 3, abundant iron formation in the glacial drift, and 4, the evidence given by the topography. The last three are the ones that must be depended on in any particular small area. The general lines of evidence are given on pages 46 to 49.

For the purpose of this discussion it is necessary to recall what an iron formation is; that it occurs in beds that are continuous

for considerable distances, like any other sediment; and that it may occur as a great formation 1000 feet or more in thickness, as minute stringers like the partings of shale in a sandstone, or as a formation of any intermediate thickness.

The term "iron formation" is used to denote a distinctive type of rock formation in which the iron ores of the Lake Superior region occur. This rock is a chemical sediment consisting of iron oxide or carbonate and cherty silica with varying amounts of ordinary sediment as impurities. These impurities are variously sand, clay, limestone or volcanic ash. With increase in the percentage of impurity the rock becomes a ferruginous quartzite (in which quartz sand is an important constituent), a ferruginous shale or slate (in which clay sediments are the abundant impurity), a ferruginous limestone, or a ferruginous volcanic ash. There is complete gradation from the pure iron carbonate or oxide and cherty silica combination to these other phases. Because of the fact that shales make up such a great part of all sediments the most common impurity in iron formation rocks is shale, and the most common gradation is to ferruginous shale or slate.

Not only is there complete gradation from iron formation to these common sediments named but there is just as perfect gradation from pure iron ores to iron formation. The pure hematite ore contains 70% of iron and 30% of oxygen, and pure magnetite contains 72% of iron and 28% of oxygen. The line of demarkation between iron ore and iron formation is not definite. It is determined by the demands of the market, competition with other ores, freight rates and other economic factors. Although lower grades are sold in small amounts in the Lake Superior region, the lower limit for ore is about 50% iron (natural). Material containing 40% to 50% of iron may be called ore on the assumption that sometime in the future this grade will be used. Rock containing less than 40% of iron is ordinarily called iron formation until its percentage of iron gets as low as 15% to 20%. The average iron content of 32,416 feet of drilling by the Oliver Mining Co.\* in what was called iron formation by them was 36.8%. This is probably very close to the average iron content of the iron formations of the five principal ranges of the Lake Superior region in which this drilling was done. Quoting from Monograph LII, "These analyses include both the lean, and the partly concentrated parts of the iron-bearing formations, but do not include the available ore.

\*Mon. LII, page 491.

If the partly concentrated parts of the formation are left out of consideration, the average would be 25 per cent of iron."

These iron formations have been metamorphosed in many ways so that they assume a number of different phases. They have been altered by solutions which have oxidized the iron and leached out the silica, thus producing the ores. They have been changed by igneous intrusion and dynamic metamorphism so that complex iron silicate and magnetite rocks have resulted, the amphibole-magnetite rocks or grünerite schists. This form is usually more resistant to erosion than other forms. They have also been altered to hard banded jaspers by folding and compression and the higher temperatures due to great depths of burial.

Various horizons of a single iron formation may be altered to these different phases, or adjacent parts of the same horizon may exhibit them, depending upon the conditions of metamorphism to which the different parts have been subjected, and the composition of the different parts before they were altered. It is quite common to find the basal part of an iron formation in the form of an amphibole-magnetite rock, and the upper portions either in the original condition or partly oxidized and leached. In such a case the basal part is more likely to outcrop than the remainder, and the wrong impression is quite likely to result, that the whole formation is the undesirable amphibole-magnetite rock.

If the whole of a thick formation has been changed to an amphibole-magnetite rock it is less likely to contain ore deposits than other phases of iron formation, but it exhibits strong magnetic attractions over its whole width. For this reason strong magnetic attractions have proved to be rather disappointing indications for the prospector. If the formation is thin and has all been altered to amphibole-magnetite rock it will give strong magnetic attractions along a narrow belt. On the other hand, if only a limited horizon of a thick iron formation has been thus altered it will give the same effect as a thin formation entirely altered. The thick formation offers encouragement to prospecting and the other does not. Usually the only way to tell which case is present is to drill a number of holes and make a cross-section of the formation. It is not uncommon to find a thin strongly magnetic formation paralleling a thick non-magnetic formation a few hundred feet distant.

If a thin iron formation or a thin horizon of a thick one is mildly altered by igneous intrusion or by dynamic metamorphism the result



will be mild magnetic attraction along a narrow belt. These cases of mild attraction offer the greatest encouragement to the prospector in any area where magnetic attraction is one of the principal indications of the presence of iron formation. For this reason recommendations for exploration in the township descriptions are unfavorable or only mildly favorable where the magnetic attractions are strong. The most favorable magnetic indication is a long, continuous line of regular attractions varying not more than  $10^{\circ}$  or  $12^{\circ}$  from the normal dip needle reading. Many such lines are shown on the township maps of this area.

As stated in the following chapter, magnetic attraction *may* be caused by any kind of rock. The only igneous rock known to exhibit a long, narrow belt of attractions like that due to an iron formation is a greenstone or trap rock flow. Even in this case the attraction is very irregular when compared to that due to an iron formation. In the Lake Superior region there is probably not one case in fifty where a magnetic line, such as the one described above, is caused by any other rock than an iron formation. This iron formation may be thick or thin, rich or lean, but this can only be determined by drilling. The duty of the magnetic survey has been completed by showing that an iron formation is present.

Another indication of the presence of iron formation is the occurrence of iron formation and ore in the glacial drift. In order to obtain the percentage of different kinds of pebbles drift counts were made in many places. These are given on pages 63 to 74. The manner of making these counts is described on page 23. In some places the iron formation pebbles make a third or more of the total. In other places no iron formation is found in the drift.

Great abundance of iron formation in the drift is a strong indication that the ledge from which it came is close at hand. It becomes of great importance then to know the direction of movement of the ice and water which carried the material. The general movement of the ice sheet over the Huronian rocks of this area was from the northeast. Locally it changed its direction and moved northwest, west, southwest, or south. The drainage from the ice front for the most part found its way down the valley of the Chippewa and its tributaries. These local details should be worked out carefully before drilling is undertaken.

The character of the iron formation in the drift is not usually typical of the formation in the ledge. The hard jasper phases which are most resistant to stream action are bound to be the most

common in the drift. The less resistant phases are more likely to be ground to powder and washed away, leaving only the lean hard parts.

There are two kinds of iron formation found in the drift in this area. Most of it is a massive red jasper made up of oölitic granules of chert and hematite, and is almost exactly like that found a short distance northwest of Crystal Falls, Michigan. The other variety, found more commonly in the northern and eastern parts of the area, is banded red jasper and hard blue hematite.

The percentage of iron formation in the drift varies widely. In many townships where the ice moved over Huronian areas for some distance the drift counts show a high percentage of iron formation, as shown in the drift counts for T.34-7W., T.35-7W., T.35-8W., T.39-6W., T.40-6W., and T.42-7W. In the western part of the district, in the sandstone area, the percentage of iron formation is much lower, as shown in the drift counts for T.38-11W., T.39-11W., and T.39-12W. In areas where the ice moved over granites and other igneous rocks the percentage of iron formation is also low, as seen in the drift counts for the south part of T.36-7W., for T.37-6W., T.37-7W., T.38-5W., T.38-6W., the south part of T.38-7W., for T.38-8W., T.41-2W., T.42-2W., and T.43-2W.

These observations are given to show the importance of the indications of the presence of iron formation to be found by a careful study of the glacial drift. When these are carefully studied in connection with the indications given by magnetic attractions much valuable information can be obtained.

A third indication of the presence of iron formation in any locality is given by the topography. As previously explained in this chapter, the Huronian series containing the iron formation are in relatively lower areas than the granite and gneiss. Topographic evidence of a pre-glacial valley, while of itself not giving any hint of the presence of iron formation, is nevertheless an important indication to be sought for in connection with the other indications described above.

The more general lines of evidence showing that iron formation rocks are present in this general area are discussed on pages 46 to 49.

## TOPOGRAPHY AND DRAINAGE

The area described in this report is part of the Northern Highland of Wisconsin. It is a great plain with quartzite hills projecting

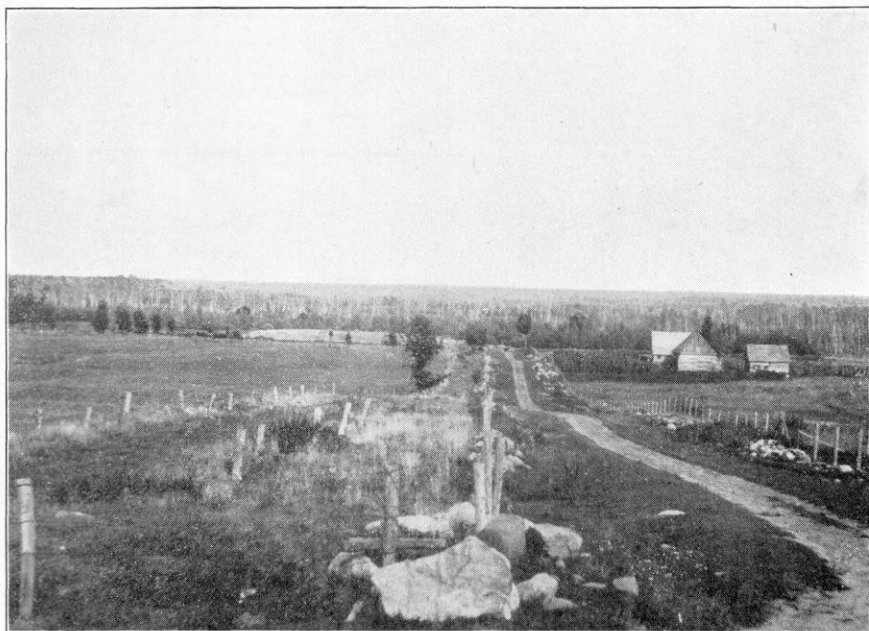

A. LOOKING EAST OVER THE VALLEY OF THE CHIPPEWA RIVER  
FROM 4 MILE EAST OF THE CENTER OF SECTION 35, T. 43-2W.  
A scene typical of the ground moraine topography.



B. VILLAGE OF MORSE IN T. 43-2W.  
Granite and gneiss outcrops laid bare by stream action.



above it, all modified by a heavy cover of glacial drift. The general relief is rather mild except in the region of the Barron quartzite and in some of the terminal moraine areas. The topography varies from flat outwash plains and terraces and monotonous marsh areas through very gently rolling ground moraines to the abrupt hummocks and kettles of the terminal moraines and the high, stream dissected, quartzite area. These features are shown in plates VII and VIII. The lowest point is the Chippewa River in T.33-6W. at an elevation of about 1,050 feet above sea level. The highest measured elevation in the main area of the map is in the Barron quartzite hills in T.37-8W. and is about 1,770 feet above sea level. As the elevations were measured along roads it is evident that higher elevations than those shown in the profiles of the various towns are numerous. The highest point in the main area is estimated to be at least 30 feet above the highest measured elevation. From the lowest to the highest point in the main area is therefore about 750 feet.

In the three townships about Monico the general elevation is much higher. The country is broadly rolling and lies at an elevation of 1,600 to 1,700 feet above sea level. In section 33 of T.36-12E. the railroad enters the town at an elevation of 1,770 feet and curves around a high hill in section 34. The elevation of this hill was determined with an aneroid barometer by Mr. J. H. Swenhardt, Jr., County Agricultural Representative at Crandon, to be 184 feet above the point where the railroad crosses the west line of section 36. This gives the summit of the hill an elevation of 1803 feet above sea level about 140 feet lower than Rib Hill near Wausau, which is the highest measured elevation in the state. This hill is about 300 feet above the valley of Wolf River, three miles west.

The area included in the map, plate I, is nearly all within the thick drift of the latest ice invasion, and lies in the headwater portions of the drainage basins. The drainage is consequently very poorly developed. The streams have not eroded their channels greatly since glacial time. Rapids and small falls are common. Marshes of all shapes and sizes are numerous, and there are many lakes.

As should be expected in such a large irregular area the drainage finds its way into several major streams. Except from parts of T.43-2 and 4W., and T.36-12E., all the streams flow into the Mississippi River. The eastern part of the main area is in the Wisconsin River watershed. The greater part of the area is drained by the Chippewa and its chief tributaries, the Flambeau, Thornapple, Brunet, Couderay, West Fork, and Red Cedar rivers. The waters of the

western part find their way into the St. Croix through the Namakagon and Yellow rivers. The three townships to the east lie on the height of land between the St. Lawrence and Mississippi drainage basins, which they reach through the Wisconsin and Fox rivers.

The river courses are varied and tortuous in detail but there is a striking parallelism in the general courses of the major streams west of the Ashland Division of the "Soo" railroad. The predominant direction of flow is southwest—parallel to the general direction of slope of this part of the area. There are numerous changes to a southward or even a south-eastward direction of flow for considerable distances in the Chippewa drainage, and to a northwestward direction in the St. Croix waters. These facts are best appreciated after a careful inspection of the general map—Plate I.

There are many beautiful lakes which are famous among sportsmen for their large game fish. Many of them lie in depressions with no outlets, and their waters find escape only by seepage through the porous glacial deposits in which they lie. While the outlines of many of the lakes are exceedingly irregular in detail, in a general way they either have their long axes in a northeast-southwest direction, or make a series of lakes extending in this direction. The most striking instance of this is the group of lakes extending from southwest of Long Lake in T.37-11W. to Namakagon Lake in T.43-6W. To the southeast is another line with Red Cedar and Chetac lakes, and smaller lakes to the northeast. This linear arrangement strongly suggests that they lie in pre-glacial valleys which have been dammed by the glacial drift. The extent of the filling of these valleys and the size of the moraines is such that a number of the lakes in the Long-Namakagon group drain to the northwest or southeast between the moraines rather than down the axis of the old valley. The following table gives the known facts with regard to the more important lakes in the area.



A. PITTED OUTWASH PLAIN IN T. 37-4E.  
 Numerous great flat areas of this sort are found in northern Wisconsin.  
 The depressions are occupied by lakes and swamps.



B. TERMINAL MORaine NORTH-EAST OF GLIDDEN, WITH  
 HUMMOCKY SURFACE THICKLY STREWN WITH BOWLERS.





TABLE II\*

Lake	Town	Range	County	Greatest length in miles	Greatest breadth in miles	Area		Maximum known dep in feet
						Square miles	Acres	
Balsam.....	37N	10W	Washburn	1.90	0.40	0.60	384.0	42.6
Big Siasabagama (Flat).....	38N	9W	Sawyer	2.45	0.75	1.45	928.0	47.6
Big Spider.....	42N	7W	Sawyer	2.49	irreg.	2.78	1,779.2	47.6
Birch.....	37N	10W	Washburn	0.90	0.70	0.38	243.2	57.4
Blue or Rusk.....	39N	6E	Oneida	1.35	1.00	0.85	544.0	44.3
Grindstone.....	40N	8 & 9W	Sawyer	3.40	2.10	5.41	3,462.4	47.6
Island.....	33N	8W	Rusk	1.75	0.65	0.68	435.2	47.6
Kathrine.....	38N	6E	Oneida	2.25	irreg.	0.95	608.0	27.9
Kawaguessa.....	39N	6 & 7E	Oneida	4.25	irreg.	3.23	2,067.2	55.8
Lac Court Oreilles.....	39 & 40N	8 & 9W	Sawyer	5.65	1.90	8.20	5,248.0	67.2
Little Duck (Teal).....	42N	6W	Sawyer	2.20	1.10	1.66	1,062.4	16.4
Little Siasabagama.....	38N	9W	Sawyer	1.00	0.80	0.50	320.0	49.2
Little Spider (Munson).....	42N	7W	Sawyer	1.00	0.65	0.36	220.4	19.7
Long.....	37 & 38N	10 & 11W	Washburn	9.25	irreg.	5.72	3,660.8	75.4
Lost Land.....	42N	6W	Sawyer	2.50	irreg.	2.32	1,484.8	15.7
Nama-kagon.....	43N	6W	Bayfield	4.50	irreg.	5.75	3,680.0	32.8
Owen.....	43 & 44N	7W	Bayfield	6.25	irreg.	3.13	2,032.0	88.6
Perry.....	43N	7W	Bayfield	0.66	0.25	0.11	70.4	16.4
Red Cedar.....	36N	10W	Barron	4.50	1.40	3.62	2,318.8	49.2
Round.....	41N	7 & 8W	Sawyer	4.75	2.90	5.60	3,584.0	59.0
Swenson.....	43N	7W	Bayfield	1.25	0.35	0.31	198.4	17.4
Tomahawk.....	38 & 39N	6 & 7E	Oneida	4.50	irreg.	5.70	3,648.0	73.8
Whitefish.....	39N	9W	Sawyer	2.60	0.65	1.40	896.0	73.8

\*Taken from Bull. XXVII, Wis. Geol. Survey. Hydrography & Morphometry of Wisconsin Lakes, 1913. C. Juday.

In his article on the "Geology of the Upper Flambeau Valley" F. H. King describes the lakes of this area as follows:

"Nearly all of the lakes, so far as observed, possess the characteristics peculiar to those of broad, morainic belts. They are beautiful sheets of water, clear, soft and deep, encircled by bold, fantastic rims, and dotted with tree-clad island cones of such varied beauty in the autumn season, that as one toils in unexpectedly upon them up the rapids of the narrow shaded rivers, he forgets his fatigue and revels in an exquisite garden of foliage plants. Sometimes a fringe of white cedar lies upon the water's edge; higher up a wreath of white birch, then a belt of poplar, and, capping the rounded hill-tops, maple and yellow birch, throughout all of which there is a generous setting of rich green white and Norway pines. Gravelly beaches and weedless sandy bottoms are the rule, and small marshes are of rare occurrence. Muskellunge and yellow pike-perch are common. \* \* \* \*

"Fantastic as are the contours of many of the lakes, especially in the upper lake region, there is, after all, something of regularity in the distribution of bays, capes and islands, as well as in the positions of the longer axes of many of the lakes. The majority of those lakes which are longer than wide have the longer axes generally trending N. E. and S. W., or in the direction of glacial movement,

and the stronger land and water indentures often lie in pairs, and trend in the same direction.”\*

These lakes are some of the beauty spots of northern Wisconsin which amply justify its description as “the Playground of the Middle West.” Numerous attractive summer resorts and cottages dot their shores. Thousands of people annually spend their vacations here and many other thousands will come as transportation becomes easier and the beauty of the lakes become more widely known.

### ANALYSIS OF GLACIAL DRIFT

The constitution of the glacial drift is one of the important criteria that must be used in this district to determine the character of the bed rock. Examples of the use of these drift analyses are given on page 58. The method of making them is described on page 23. A large number of such analyses were made in the field work in this area. The results are given in the following pages for the convenience of those who may wish to use them as a basis for the more detailed study of the constituents of the glacial drift that should be made before drilling operations are begun.

It is certain that the personal equation plays a large part in the selection of the pebbles to be counted. Even though he may be consciously striving not to select an unduly large proportion of any one kind of rock, a man can hardly avoid paying more attention than he should to the varieties of rock most interesting to him. In this work every possible indication of iron formation was diligently searched for, and it is quite probable that the geologists were influenced more or less by this fact. The initials of the geologist making the drift count (the name can be found on the map of the township) are given in each case so that the counts made by one man can be compared with those made by others.

The towns are arranged in the same order as the maps in Part II; the southernmost township is given first, then those of the next tier north beginning at the easternmost range and going west, then the next tier beginning at the east, and so on.

\*King, F. H., *Geol. of Wis.*, 1879. Vol. IV., page 610.

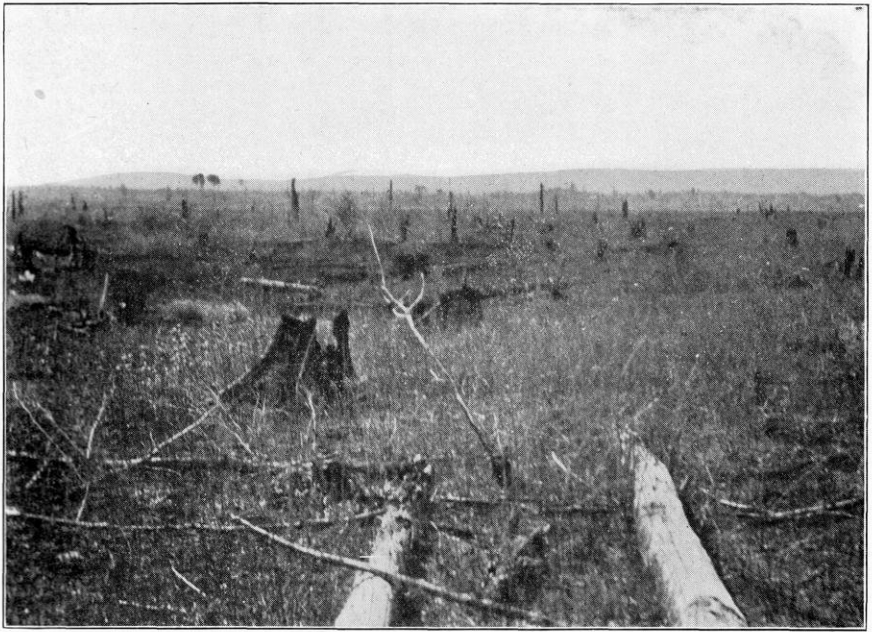

A. LOOKING SOUTH TOWARD FLAMBEAU RIDGE—OUTWASH PLAIN  
IN THE FOREGROUND.  
The stumps and fallen logs are all that is left of the pine forest that once  
covered this plain.

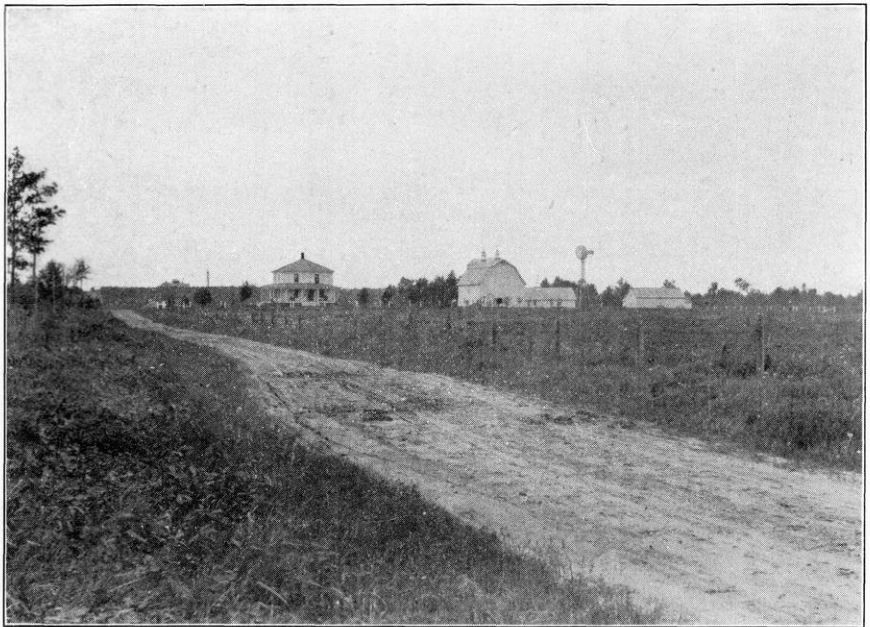

B. A FINE FARM DEVELOPED ON PART OF THE SAME OUTWASH  
PLAIN SHOWN IN FIGURE A. ABOVE.



Location	Granite	Porphyry	Gabbro	Fine Greenstones	Schists	Quartzites	Sandstone	Iron Formation	Quartz	Other Rocks	Geologist
----------	---------	----------	--------	------------------	---------	------------	-----------	----------------	--------	-------------	-----------

T. 32 N., R. 7 W.

S. $\frac{1}{4}$ 24.....	23	10	.....	25	.....	10	9	18	5	.....	O. W. W.
N. E. $\frac{1}{4}$ 13.....	23	26	.....	14	.....	12	12	8	4	1	O. W. W.
E. $\frac{1}{4}$ 12.....	18	20	5	14	.....	13	7	8	.....	15	O. W. W.
Center 18.....	26	19	8	8	.....	6	12	19	2	.....	H. Q.
S. $\frac{1}{4}$ 15.....	20	27	.....	24	.....	9	9	5	3	3	O. W. P.
N. E.-N. E. 20.....	16	15	17	19	3	7	7	14	.....	2	O. W. P.
N. E.-S. E. 10.....	25	19	21	13	3	8	6	2	.....	3	O. W. P.

T. 33 N., R. 7 W.

E. $\frac{1}{4}$ Cor. 35.....	21	22	6	24	2	2	6	13	1	3	O. W. W.
N. $\frac{1}{4}$ Cor. 36.....	16	26	1	20	1	8	7	15	4	2	O. W. W.
N. $\frac{1}{4}$ Cor. 16.....	16	26	18	14	12	.....	2	12	.....	.....	H. Q.
Center 32.....	26	20	19	16	9	6	3	.....	.....	1	O. W. P.
S. W.-S. W. 29.....	32	12	8	19	3	13	5	7	.....	1	O. W. P.
N. $\frac{1}{2}$ 19.....	30	29	3	10	.....	13	.....	11	2	2	O. W. P.
Bet. 19-20.....	21	23	6	19	4	10	2	10	3	2	O. W. P.

T. 33 N., R. 8 W.

S. E. Cor. 32.....	24	7	29	12	2	24	.....	.....	2	.....	L. R.
S. W. Cor. 7.....	15	24	4	17	2	12	8	12	6	.....	L. R.
Sec. 3.....	14	14	28	.....	.....	24	10	.....	6	4	L. R.
S. E. Cor. 23.....	15	47	2	12	.....	8	.....	16	.....	.....	G. B.
S. E. $\frac{1}{4}$ of N. E. $\frac{1}{4}$ -4 ..	24	28	12	2	.....	14	4	8	6	2	G. B.
S. $\frac{1}{4}$ 27.....	24	12	8	28	.....	8	4	.....	16	.....	J. P. G.

T. 34 N., R. 7 W.

N. E. Cor. 4.....	30	14	6	11	.....	19	9	9	2	.....	O. W. P.
N. E.-N. E. 19.....	23.0	18.9	2.8	2.8	7.1	13.2	4.4	23.5	.....	4.3	G. S. N.
Sec. 5.....	23.5	.....	22.5	20	1	8.5	2	18.5	4	.....	G. S. N.
S. W. Cor. 6.....	37	.....	7	18	3	7	.....	21	7	.....	G. S. N.
S. $\frac{1}{4}$ -4.....	27.5	12.7	13.8	9.2	6.9	2.3	6.9	13.8	2.3	4.6	H. Q.

T. 34 N., R. 8 W.

N. E. $\frac{1}{4}$ of S. E. $\frac{1}{4}$ 36....	10	23	30	4	4	13	6	6	4	.....	L. R.
---	----	----	----	---	---	----	---	---	---	-------	-------

## MINERAL LAND CLASSIFICATION

Location	Granite	Porphyry	Gabbro	Fine Greenstones	Schists	Quartzites	Sandstone	Iron Formation	Quartz	Other Rocks	Geologist
----------	---------	----------	--------	------------------	---------	------------	-----------	----------------	--------	-------------	-----------

T. 34 N., R. 9 W.

N. E.-N. E.-5.....	8	27	9	32	1	12	4	4	.....	3	G. M. S.
N. E.-N. E.-29.....	17	14	10	16	.....	7	6	12	12	6	G. M. S.
S. W. Cor. 21.....	.....	4	.....	27	.....	33	13	3	20	.....	S. M. W.

T. 35 N., R. 7 W.

S. E. $\frac{1}{4}$ of S. W. $\frac{1}{4}$ -35.....	16	36	6	4	.....	24	6	8	.....	.....	L. R.
S. W. $\frac{1}{4}$ of S. W. $\frac{1}{4}$ -2.....	33	11	.....	10	.....	11	11	24	.....	.....	G. B.

T. 35 N., R. 8 W.

S. W.-S. W.-29.....	16	18	20	.....	.....	24	6	6	4	6	L. R.
N. E.-N. E.-19.....	12	14	16	9	.....	30	7	12	.....	.....	L. R.
S. E.-N. E.-26.....	10	18	10	8	.....	28	6	20	.....	.....	G. B.

T. 35 N., R. 9 W.

S. E. Cor. 32.....	16	9	3	24	.....	32	4	12	.....	.....	W. I. R.
--------------------	----	---	---	----	-------	----	---	----	-------	-------	----------

T. 35 N., R. 10 W.

N. W.-S. E.-7.....	36	12	4	32	.....	.....	4	8	.....	4	S. M. W.
--------------------	----	----	---	----	-------	-------	---	---	-------	---	----------

T. 36 N., R. 12 E.

Center 31.....	24	10	4	24	6	18	6	2	.....	6	F. B. P.
S. E.-S. E.-35.....	25	4	11	18	6	22	10	4	.....	.....	F. B. P.
S. E.-N. E.-20.....	44	14	10	22	6	.....	.....	4	.....	.....	O. W. P.

Location	Granite	Porphyry	Gabbro	Fine Greenstones	Schists	Quartzites	Sandstone	Iron Formation	Quartz	Other Rocks	Geologist
----------	---------	----------	--------	------------------	---------	------------	-----------	----------------	--------	-------------	-----------

T. 36 N., R. 11 E.

N. W.-N. W.-30.....	36	17	4	14	3	5	1	5	11	4	W. L. D.
N. E. ¼ of N. E. ¼-8....	35	15	5	27	2		2	1	13		W. L. D.
S. E.-N. E.-30.....	36	12	5	30		5	1		10	1	W. L. D.
Center 26.....	35	9	14	18	11	6		6	1		O. W. P.

T. 36 N., R. 10 E.

Center 26.....	46	2	10	24	10		6	2			O. W. P.
----------------	----	---	----	----	----	--	---	---	--	--	----------

T. 36 N., R. 3 E.

Center 28.....	19	29	6	10	4	16	12	2	2		E. T. H.
S. E. Cor. 16.....	22	19	16	19	3	9	6		6		E. T. H.
S. E.-N. E.-31.....	21	26		23	2	21	2	2		3	R. W. C.

T. 36 N., R. 2 E.

S. E. Cor. 34.....	50			40					10		C. O.
S. E. Cor. 34.....	40			50					10		C. O.
S. E. ¼ of N. E. ¼-21....	11	39		33	8	9					J. C. S.
S. E. ¼ of N. E. ¼-24....	18	8		52	4	8		7		3	J. C. S.

T. 36 N., R. 7 W.

N. ¼ Cor. 28.....	20	12	18	18	2	12	6	8	4		O. W. P.
S. W. Cor. 19.....	24	10	6	18	4	34	2	2			O. W. P.
Sec. 23.....	40	6	8	5		38			2	1	G. S. N.
S. E. ¼ of N. W. ¼-34....	29	27	8	10	1	10	3	10		2	H. Q.
N. ¼ Cor. 15.....	36	20	2	12	2	12	2	14			H. Q.
S. E. Cor. 2.....	34	12	18	10		6	4	14	2		H. Q.

T. 36 N., R. 8 W.

S. E.-S. E.-16.....	12	18	12	14	2	16		14	6	6	L. R.
---------------------	----	----	----	----	---	----	--	----	---	---	-------

## MINERAL LAND CLASSIFICATION

Location	Granite	Porphyry	Gabbro	Fine Greenstones	Schists	Quartzites	Sandstone	Iron Formation	Quartz	Other Rocks	Geologist
----------	---------	----------	--------	---------------------	---------	------------	-----------	-------------------	--------	-------------	-----------

T. 36 N., R. 9 W.

S. W.-S. W.-5.....			30	40		15				15	J. R.
--------------------	--	--	----	----	--	----	--	--	--	----	-------

T. 37 N., R. 4 E.

Center 11.....	41	11	15	8	13	12					H. H. B.
----------------	----	----	----	---	----	----	--	--	--	--	----------

T. 37 N., R. 3 E.

S. $\frac{1}{4}$ Cor. 19.....	27	9	8	37		8	5	3	2		R. W. C.
$\frac{1}{4}$ mi. E. of S. W., Cor. 19	36	4	8	24		12	8		2	6	R. W. C.
S. E. $\frac{1}{4}$ of S. E. $\frac{1}{4}$ -7.....	37	5	7	24		15	8	3		1	R. W. C.

T. 37 N., R. 6 W.

N. $\frac{1}{4}$ Cor. 20.....	23	10	13	19		10	8	13	4		W. C. B.
S. $\frac{1}{4}$ Cor. 17.....	36	16	12	4		20		2	10		G. S. N.

T. 37 N., R. 7 W.

Center 18.....	19	31	6	16		18		8	2		H. Q.
----------------	----	----	---	----	--	----	--	---	---	--	-------

T. 37 N., R. 8 W.

S. W.-N. W.-13.....	16	18	10	24		14	8	10			W. C. B.
S. W.-N. W.-14.....	14	12	18	12	2	24	6	8	4		W. C. B.
N. W. Cor. 30.....	24	2	11	19		12		32			G. S. N.
N. W. Cor. 29.....	11	6	19	29		15		20			G. S. N.





## MINERAL LAND CLASSIFICATION

Location	Granite	Porphyry	Gabbro	Fine Greenstones	Schists	Quartzites	Sandstone	Iron Formation	Quartz	Other Rocks	Geologist
T. 38 N., R. 6 W.											
S. W. 34.....	24	22	14	12	.....	16	2	10	.....	.....	H. Q.
T. 38 N., R. 7 W.											
Center 15.....	14	4	7	17	4	5	.....	47	2	.....	G. S. N.
N. E. Cor. 23.....	26	18	26	8	2	2	10	6	2	.....	H. Q.
N. ¼ Cor. 36.....	19	23	10	17	.....	17	6	6	.....	2	H. Q.
T. 38 N., R. 8 W.											
½ mi. S. E. on R. R. from C. 16.....	24	15	25	15	.....	19	.....	.....	1	1	G. S. N.
Center 22.....	28	15	14	16	.....	18	.....	6	1	2	G. S. N.
Section 3.....	31	21	6	3	.....	21	3	12	3	.....	H. Q.
Center 27.....	26	16	24	14	.....	10	2	8	.....	.....	H. Q.
Section 11.....	28	9	9	21	.....	18	6	6	.....	3	H. Q.
¼ mi. N. Center 30.....	14	14	14	24	.....	26	2	6	.....	.....	W. C. B.
¼ mi. N., S. E. Cor. 6..	18	8	14	26	1	23	2	6	.....	2	W. C. B.
T. 38 N., R. 9 W.											
Center 23.....	3	10	.....	62	.....	8	14	1	2	.....	R. W. C.
S. ¼ Cor. 2.....	6	25	.....	14	.....	20	17	10	7	1	R. W. C.
N. E. Cor. 14.....	9	8	.....	48	.....	19	10	1	1	4	R. W. C.
T. 38 N., R. 11 W.											
S. W.-N. W.-25.....	6	11	24	26	2	7	16	5	3	.....	O. W. P.
S. W.-S. W.-5.....	8	15	7	46	.....	11	6	5	.....	2	W. L. D.
Center 29.....	12	11	2	45	.....	19	3	4	.....	4	W. L. D.
½ mi. E. ¼ Cor. 4.....	7	4	37	17	.....	14	5	3	.....	13	D. G. T.
Center 16.....	12	9	25	18	.....	15	8	3	.....	10	D. G. T.

Location	Granite	Porphyry	Gabbro	Fine Greenstones	Schists	Quartzites	Sandstone	Iron Formation	Quartz	Other Rocks	Geologist
----------	---------	----------	--------	------------------	---------	------------	-----------	----------------	--------	-------------	-----------

T. 39 N., R. 2 E.

S. E.-S. E.-24.....	32	16	.....	20	3	8	8	4	.....	9	R. N. H.
S. W.-S. E.-6.....	27	14	.....	28	10	7	6	5	.....	3	R. N. H.
N. W. Cor. 35.....	26	18	4	14	4	16	10	8	.....	.....	F. B. P.
N. W. ¼ S. W. ¼ 23.....	25	27	4	21	.....	5	8	2	.....	8	F. B. P.
N. W.-N. E.-14.....	20	12	10	31	.....	13	10	4	.....	.....	F. B. P.

T. 39 N., R. 1 E.

S. ¼ Cor. 36.....	28	10	3	29	.....	10	4	5	.....	11	R. N. H.
S. E.-S. E.-2.....	24	14	.....	36	4	12	6	.....	.....	4	R. N. H.
¼ mi. S. Cen. 28.....	28	12	16	26	6	2	4	6	.....	.....	C. S. G.
N. E.-N. E.-15.....	30	20	14	12	4	12	.....	8	.....	.....	C. S. G.
N. E.-N. E.-28.....	46	8	20	9	.....	7	2	8	.....	.....	C. S. G.
S. W.-S. E.-3.....	39	22	12'	19	.....	.....	5	3	.....	.....	C. S. G.

T. 39 N., R. 1 W.

¼ mi. N. W. Center 24..	24	14	10	34	.....	4	4	4	.....	6	R. N. H.
-------------------------	----	----	----	----	-------	---	---	---	-------	---	----------

T. 39 N., R. 3 W.

¼ mi. S. Center 5.....	9	14	7	32	.....	4	15	7	5	7	C. R. S.
¼ mi. N. S. W. Cor. 14..	8	24	24	18	.....	10	3	8	4	1	H. J. A.

T. 39 N., R. 4 W.

¼ mi. N. W. S. E. Cor. 3	9	22	9	30	1	7	8	10	.....	4	H. J. A.
¼ mi. W. E. ¼ Cor. 23..	20	30	5	28	2	5	3	7	.....	.....	H. J. A.

T. 39 N., R. 5 W.

S. W. ¼ N. W. ¼ 2.....	15	24	5	24	.....	15	3	5	5	4	C. R. S.
¼ mi. N. S. E. Cor. 22	19	23	.....	18	7	11	14	5	.....	3	H. J. A.
N. E. ¼ of N. E. ¼ 10..	27	22	18	10	.....	8	5	7	.....	3	H. J. A.

## MINERAL LAND CLASSIFICATION

Location	Granite	Porphyry	Gabbro	Fine Greenstones	Schists	Quartzites	Sandstone	Iron Formation	Quartz	Other Rocks	Geologist
----------	---------	----------	--------	------------------	---------	------------	-----------	----------------	--------	-------------	-----------

## T. 39 N., R. 6 W.

S. W. Cor. 19.....	14			30		12	12	32			C. A. W.
S. E. Cor. 11.....	23	8		39		5	3	22			C. A. W.
Section 35.....	22	4		4	32	4	2	32			C. A. W.
Center 23.....	17	12	21	4		11	8	26		1	C. W. H.
N. E. Cor. 17.....	13	13		32		12	12	17		1	C. W. H.

## T. 39 N., R. 8 W.

S. W.-S. W.-8.....	13	13	6	23		16	15	3	5	6	L. J. Y.
N. ¼ Cor. 30.....	22	9	25	12		14	5	12	1		H. N. E.

## T. 39 N., R. 11 W.

N. E.-N. E.-11.....	8	13	10	32		11	11	4	2	9	W. L. D.
S. E.-S. E.-27.....	4	16	7	35		17	6	12	3		W. L. D.
¼ mi. N. S. W. Cor. 34..	11	10	12	28		18	9	8	2	2	W. L. D.
N. E.-N. E.-7.....	10	3	29	18	2	5	19	1	1	12	D. G. T.
S. W.-S. E.-35.....	18	13	14	22	5	8	14	1	3	2	O. W. P.

## T. 39 N., 12 W.

Center 3.....	5	16	23	30		3	9	7		7	W. L. D.
N. ¼ Cor. 3.....	9	25	12	28		4	13	8		1	W. L. D.
¼ mi. E. N. ¼ Cor. 5..	9	16	25	31		7	8	4			W. L. D.
N. W.-N. E.-12.....	12	10	11	28		8	11	15		5	W. L. D.
¾ mi. N. E. S. E. Cor. 36	10	12	11	25		16	16	9	1		O. W. P.
S. E. Cor. 36.....	6	6	20	33	2	8	18	6	1		O. W. P.
S. E.-N. E.-31.....	1	2	25	30		13	22	6		1	O. W. P.
¾ mi. W. S. E. Cor. 23..	9	6	26	21		11	17	4	2	4	D. G. T.
S. W. Cor. 19.....	6	7	44	9		10	19	4		1	D. G. T.
S. W. Cor. 20.....	10	11	15	21		24	16	3			D. G. T.
N. E.-S. E.-18.....	6	4	23	21		24	21	1			D. G. T.
N. W. Cor. 13.....	2	4	25	19	3	10	18	8	1	10	D. G. T.
¼ mi. S. N. E. Cor. 20..	10	12	21	19		17	15	5		1	D. G. T.
N. E.-N. E.-21.....	8	8	34	23		11	9	4	1	3	D. G. T.
S. E.-S. E.-15.....	5	11	36	19		4	15	3		7	D. G. T.
N. W.-N. W.-13.....	6	14	20	16	1	13	15	12	1	2	D. G. T.
S. ¼-13.....	6	7	33	08		9	11	8		8	D. G. T.

Location	Granite	Porphyry	Gabbro	Fine Greenstones	Schists	Quartzites	Sandstone	Iron Formation	Quartz	Other Rocks	Geologist
----------	---------	----------	--------	------------------	---------	------------	-----------	----------------	--------	-------------	-----------

T. 39 N., R. 13 W.

N. E.-N. E.-11.....	4	11	12	42	.....	9	10	6	5	1	W. L. D.
N. E.-N. E.-1.....	6	18	13	43	.....	10	7	1	1	1	W. L. D.
S. E.-S. E.-24.....	8	20	11	32	1	12	7	3	3	3	W. L. D.
S. E.-S. E.-13.....	9	15	5	32	.....	24	2	3	3	7	W. L. D.
Center 15.....	19	10	26	19	.....	6	13	4	2	1	O. W. P.
S. E.-S. E.-33.....	18	13	18	21	.....	16	5	7	2	.....	O. W. P.
N. E.-N. E.-3.....	11	9	30	23	1	5	13	5	2	1	O. W. P.
N. E.-N. E.-20.....	8	10	38	23	.....	7	4	8	1	1	O. W. P.
N. W.-N. W.-9.....	10	9	21	24	.....	9	22	3	2	.....	O. W. P.
N. W. Cor. 18.....	6	22	11	10	.....	10	21	2	1	17	D. G. T.
S. E.-S. E.-25.....	9	16	3	5	.....	18	26	8	1	14	D. G. T.
S. E.-N. E.-31.....	4	12	23	30	.....	11	13	5	1	1	D. G. T.
S. W.-S. E.-29.....	13	16	17	20	.....	12	10	7	4	1	D. G. T.

T. 40 N., R. 1 W.

N. E.-S. E.-35.....	16	7	7	46	.....	10	3	7	.....	4	C. S. G.
Section 14.....	20	14	4	32	.....	.....	8	10	.....	12	F. B. P.
S. E.-S. E.-36.....	30	8	.....	28	6	6	6	4	.....	12	R. N. H.
N. E.-S. E.-26.....	26	12	.....	30	6	8	10	2	.....	6	R. N. H.

T. 40 N., R. 2 W.

S. E.-S. E.-30.....	32	18	8	16	.....	10	6	10	.....	.....	C. S. G.
N. E. ¼ S. W. ¼ 27.....	10	23	10	36	.....	.....	8	4	.....	9	L. R.

T. 40 N., R. 3 W.

¼ mi. N. Center 36.....	9	26	7	20	8	12	8	5	5	.....	C. R. S.
Center 6.....	13	27	16	24	4	4	9	3	.....	.....	H. J. A.

T. 40 N., R. 4 W.

Center 33.....	15	13	12	37	3	5	11	4	.....	.....	H. J. A.
½ mi. S. N. E. Cor. 19.....	28	27	13	9	2	9	6	2	4	.....	E. L. J.
S. W. ¼ N. E. ¼ 9.....	26	33	10	18	.....	5	8	.....	.....	.....	C. R. S.

## MINERAL LAND CLASSIFICATION

Location	Granite	Porphyry	Gabbro	Fine Greenstones	Schists	Quartzites	Sandstone	Iron Formation	Quartz	Other Rocks	Geologist
----------	---------	----------	--------	------------------	---------	------------	-----------	----------------	--------	-------------	-----------

T. 40 N., R. 5 W.

1/8 mi. S. E. 1/4 Cor. 29	26	16	5	24	.....	11	9	7	1	1	C. W. H.
N. E.-S. E.-35.....	21	31	8	20	2	3	3	10	.....	2	C. W. H.

T. 40 N., R. 6 W.

N. E. 1/4 of N. W. 1/4 27..	22	18	.....	6	.....	22	6	26	.....	.....	J. P. G.
N. E.-S. E.-6.....	33	6	13	2	1	16	5	23	1	.....	T. M. L.

T. 40 N., R. 8 W.

Section 28.....	22	22	13	4	2	18	9	7	3	.....	F. R. P.
S. W. Cor. 21.....	29	9	20	9	.....	5	8	19	1	.....	H. N. E.
Section 18.....	22	7	18	18	.....	3	25	1	4	2	L. J. Y.

T. 40 N., R. 10 W.

S. 1/2 of 18.....	12	13	25	11	3	8	14	13	.....	1	H. D. W.
-------------------	----	----	----	----	---	---	----	----	-------	---	----------

T. 40 N., R. 11 W.

S. E. 1/4 S. E. 1/4-12.....	4	4	29	17	1	12	20	6	1	6	D. G. T.
S. E.-S. E.-30.....	6	3	17	24	2	18	14	1	.....	15	D. G. T.
N. E.-N. E.-2.....	7	15	9	23	.....	2	26	13	.....	5	W. L. D.
N. E.-S. E.-23.....	16	8	6	33	.....	2	24	8	.....	3	W. L. D.
S. E.-S. E.-24.....	6	10	13	27	.....	11	26	3	.....	4	W. L. D.
N. W.-N. W.-3.....	11	7	13	23	.....	6	27	10	.....	3	O. W. P.
N. E.-S. E.-22.....	6	16	24	24	.....	12	8	.....	2	8	O. W. P.
1/5 mi. E. Center 28....	7	11	15	22	1	15	21	5	2	1	O. W. P.

Location	Granite	Porphyry	Gabbro	Fine Greenstones	Schists	Quartzites	Sandstone	Iron Formation	Quartz	Other Rocks	Geologist
----------	---------	----------	--------	------------------	---------	------------	-----------	----------------	--------	-------------	-----------

T. 41 N., R. 2 W.

S. W. Cor. of S. E. - S. E. - 23	75	8		15					2		J. O. B.
Section 13.....	50	30	2	10					8		J. O. B.
S. E. Cor. 14.....	50	15		20	15						J. O. B.

T. 41 N., R. 6 W.

N. ¼ Cor. 4.....	30	8	14	17		12	6	13			C. W. H.
------------------	----	---	----	----	--	----	---	----	--	--	----------

T. 41 N., R. 7 W.

S. W. - N. E. 34.....	29	9	12	6	6	15	10	11	2		F. R. P.
1/10 mi. N. S. ¼ Cor. 8..	28	18	6	20		10	10	4	3	1	L. J. Y.

T. 41 N., R. 9 W.

No location given.....	7	15	22	24	1	10	12	3	2	4	R. S. T.
------------------------	---	----	----	----	---	----	----	---	---	---	----------

T. 42 N., R. 2 W.

Center 2.....	29	20	16	27	4	3	1				H. H. B.
N. E. ¼ S. E. ¼ - 18.....	19	25		33		4	14	3		2	H. H. B.
N. ¼ Cor. 25.....	77	3		10	5					5	L. S.
¾ mi. S. N. E. Cor. 13..	24	9		20	3	16	8			20	L. S.
N. E. ¼ N. W. ¼ - 27....	60	10		30							J. O. B.

T. 42 N., R. 5 W.

Section 15.....	36	14	16			24	10				J. P. G.
S. E. - S. E. 31.....	33	11	14	21	1	6	3	9	2		C. W. H.
N. E. Cor. 11.....	27	17	10	15		8	10	10	3		C. W. H.
N. E. Cor. 35.....	42	15	9	8		8	5	10	3		C. W. H.
S. E. ¼ - N. W. ¼ - 11....	36	14	8	4		22	12	2		2	T. M. L.

## MINERAL LAND CLASSIFICATION

Location	Granite	Porphyry	Gabbro	Fine Greenstones	Schists	Quartzites	Sandstone	Iron Formation	Quartz	Other Rocks	Geologist
----------	---------	----------	--------	------------------	---------	------------	-----------	----------------	--------	-------------	-----------

## T. 42 N., R. 7 W.

$\frac{1}{10}$ mi. E. S. $\frac{1}{4}$ Cor. 9.	9	4	9	40	.....	23	1	14	.....	.....	G. S. N.
Center 31.....	11	9	6	40	.....	15	.....	15	4	.....	G. S. N.
$\frac{1}{10}$ mi. N. E. of S. W. Cor. 31.....	26	8	16	16	.....	18	.....	16	.....	.....	G. S. N.
$\frac{1}{4}$ mi. N. S. $\frac{1}{4}$ Cor. 32....	14	10	4	42	.....	14	6	8	2	.....	G. S. N.

## T. 43 N., R. 2 W.

Section 20.....	10	60	.....	15	.....	.....	15	.....	.....	.....	J. O. B.
W. of S. $\frac{1}{4}$ Cor. 33.....	19	25	21	32	1	.....	.....	2	.....	.....	H. H. B.
$\frac{1}{8}$ mi. E. Center 27.....	20	19	19	32	.....	4	2	4	.....	.....	H. H. B.
$\frac{1}{8}$ mi. S. E. $\frac{1}{4}$ Cor. 4 .....	9	18	14	18	.....	10	21	2	.....	8	H. H. B.
1-5 mi. E. Center 27.....	13	20	8	39	.....	3	10	.....	.....	7	H. H. B.

## T. 43 N., R. 4 W.

Section 34.....	25	28	28	.....	2	6	2	7	.....	2	T. M. L.
$\frac{1}{8}$ mi. W. S. E. Cor. 36 .....	17	25	.....	34	6	7	2	9	.....	.....	T. M. L.
$\frac{1}{8}$ mi. W. S. $\frac{1}{4}$ Cor. 33....	29	6	16	28	.....	2	8	9	2	.....	C. W. H.
$\frac{1}{8}$ mi. N. N. E. Cor. 23....	26	17	27	2	.....	8	19	1	.....	.....	C. W. H.

## T. 43 N., R. 5 W.

$\frac{1}{8}$ mi. S. N. $\frac{1}{4}$ Cor. 3 .....	18	12	12	4	.....	16	22	12	.....	4	J. P. G.
N. of S. $\frac{1}{4}$ Cor. 25 .....	17	17	46	.....	.....	7	6	7	.....	.....	C. W. H.
$\frac{1}{8}$ mi. N. $\frac{1}{8}$ mi. E. N. $\frac{1}{4}$ Cor. 5.....	21	9	22	26	.....	14	.....	5	3	.....	G. S. N.



## CHAPTER IV

## MAGNETIC OBSERVATIONS

## SECTION I. GENERAL PRINCIPLES

*Local Magnetic Attractions.*—Magnetic observations are of value in geological work for the principal reason that they indicate the location and strike of bedded magnetic rocks. In many cases the approximate dip and the depth of burial of the formation can also be deduced from a series of observations. The magnetic attraction of rocks is due to the presence of magnetite. While the oxidation of pyrite frequently results in a product which is magnetic, and oxidized pyrite can oftentimes be followed by the magnetic attraction, this is usually a minor phenomenon, of veins and not of bedded rocks. Any rock in which magnetite exists in appreciable amount will show more or less magnetic attraction. This mineral is found in a great variety of rocks. It occurs in minor quantities in all igneous rocks and in very considerable quantities in some of the more basic varieties. It is also found in sedimentary rocks, either as a primary mineral, or as a secondary mineral developed in place, and in either case may form either a minute part or the major part of the rock.

Economically the most important rocks that contain magnetite, and therefore exhibit magnetic attraction, are the rocks known as iron-bearing formations. It is in the finding and tracing out of rocks of this character that magnetic observations find their chief value in economic geology. Magnetic observations are also very useful in tracing out the strike of other rocks, as greenstones, slates or quartzite, in which there are beds containing sufficient magnetite to exhibit local attraction, and in this way they give data on the geologic structure in regions where outcrops are few or lacking.

*Brief General Discussion of Magnetic Fields.\**—The earth may be considered as a magnet in which the lines of force have the direction and vertical angles shown in figures 4 and 5. These lines of

\*An excellent discussion is contained in "Principal Facts of the Earth's Magnetism and Methods of Determining the True Meridian and the Magnetic Declination," published by the U. S. Coast and Geodetic Survey, 1909. A very good general treatment of magnetism is "Magnetism and Electricity for Students" by H. E. Hadley, published by MacMillan & Co.

force show the direction which would be assumed by a perfectly balanced magnetic needle free to swing in all directions. The variation (from true north) of the horizontal projection of the lines of force is known as the *declination*. The angle between their direction and the horizontal is known as the *inclination*.

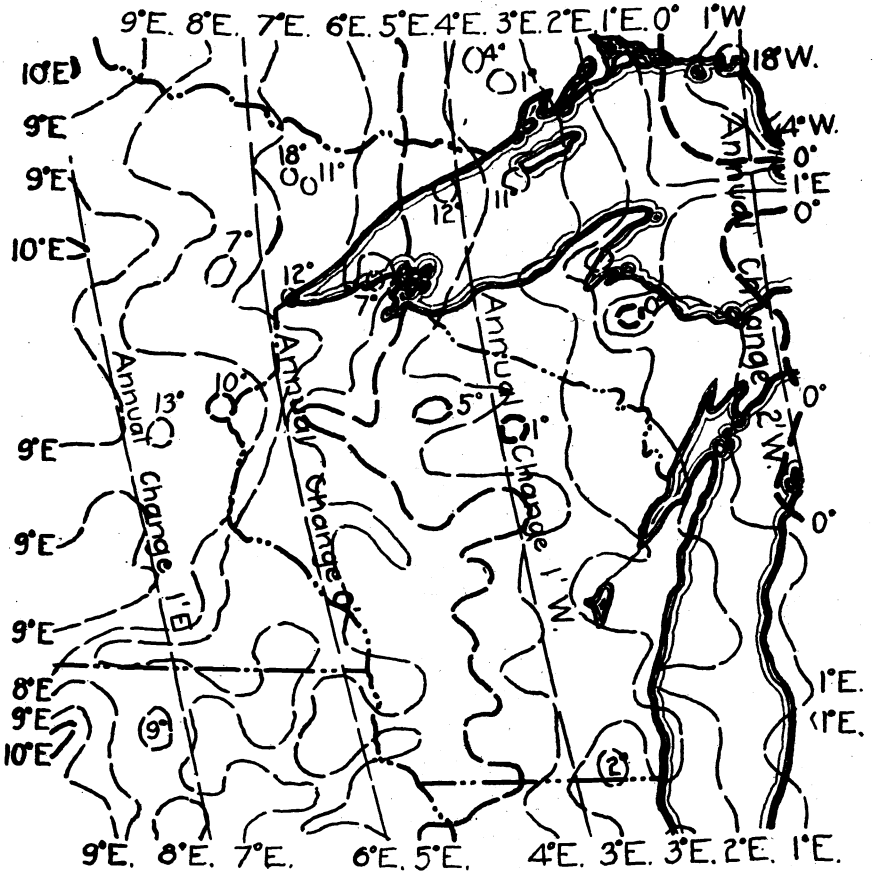

Fig. 4. Lines of equal declination and equal annual change. From U. S. Coast and Geodetic Survey chart.

In addition to this property of *direction*, the magnetic field possesses the property of *intensity*. If a compass laid upon a table is approached from one side by a bar magnet, the deflection noticed will be greater as the magnet gets closer. The intensity of the field varies inversely as the square of the distance for a bar magnet and as the first power of the distance for a sheet magnet such as a

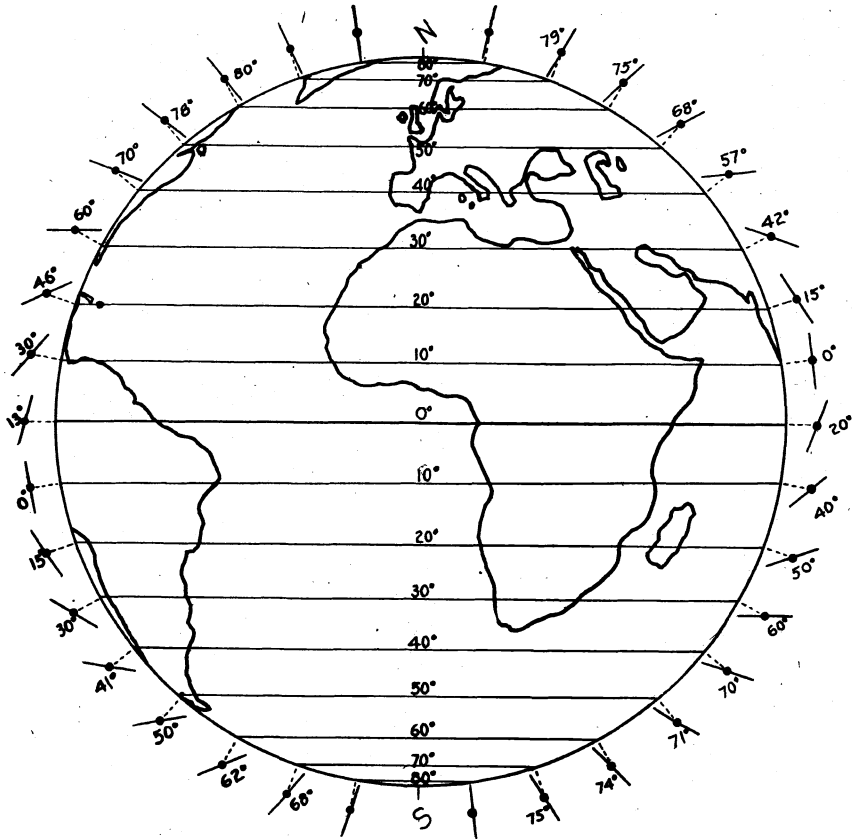

Fig. 5. Inclination of the magnetic field to the earth's surface on a great circle through the Lake Superior iron district.

magnetic iron formation. The field of attraction of a magnet is usually indicated in a drawing by lines of force, in which the spacing of the lines roughly indicates the intensity. If into such a field some magnetic material, such as metallic iron or magnetite is introduced, there is produced a local change both in the direction and intensity of the magnetic attraction.

Over any small area, such as a township, free from magnetic rocks, the direction and strength of the magnetic field of the earth are the same at one point as at another. The earth's normal field is for this reason known as a *uniform field* and represented by evenly-spaced parallel lines, as in figure 7. If into such a uniform field the geological processes of deposition, folding, metamorphism and erosion have introduced a magnetic formation, the effect on the field is of the same nature as that shown in the field of an ordinary magnet when a piece of iron is introduced. It is these local changes of the normal magnetic field of the earth, both in direction and intensity, which enable us to discover, by means of magnetic observations, the presence of covered rocks containing magnetite.

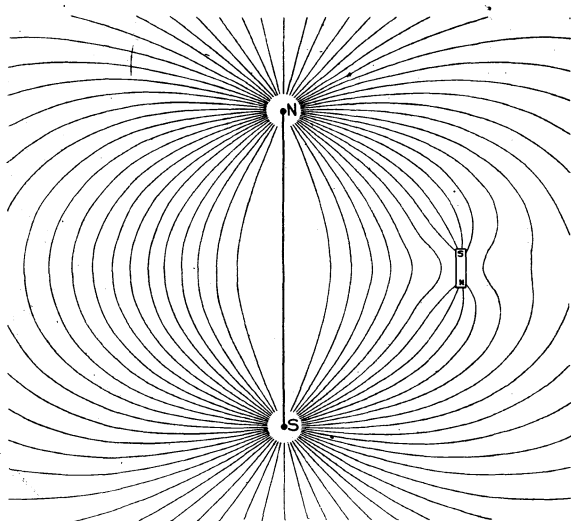

Fig. 6. The effect of a magnetic substance on the field of a larger magnet.

The magnetic field where local attraction is present may be considered as a combination of a uniform field (the normal field of the earth in that locality) and a non-uniform field due to the magnetic formation causing the local attraction. Figure 7 illustrates such a field—the parallel, equally-spaced, straight lines representing the uniform field of the earth, the dashed lines representing the field of the magnetic formation, and the heavy curved lines representing the resultant field. The figure is a section parallel to the magnetic meridian and the magnetic formation is assumed to strike east and west, and dip to the south.

If a horizontal line *S-S* be drawn anywhere above the top of the magnetic formation it would represent the surface of the ground, and the distance from it to the formation would represent the depth of the glacial drift. The directions of the lines of force affecting the compass needles would be given at the intersections of the line *S-S* and the heavy lines of the resultant field. It is readily seen that the angles at which *S-S* cuts the lines of the resultant field will vary as it is higher or lower on the drawing, and that the intensity of the field will decrease with distance.

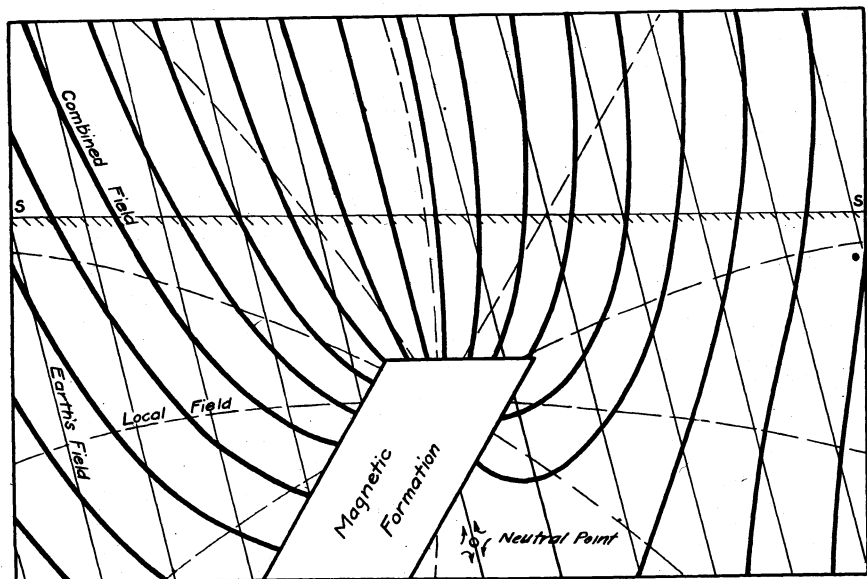

Fig. 7. A magnetic field due to the combination of the local field of a magnetic formation and the earth's field.

It is apparent that changing the strike of the magnetic formation from E-W, as shown in the figure, to N-S would make its field quite different. All the lines of force of the local field would lie in a plane perpendicular to that of the drawing. Intermediate strikes would have intermediate effects. Changes in the strength of the magnetic formation would also notably alter the configuration of the field. While all these changes and their effects on the local field can be worked out, either graphically or by computation, it is evidently too complex a problem to present here. Every person engaged in making magnetic observations should, however, picture to his mind the various cases and the effects on the resultant local field if he is to understand and interpret his results correctly.

Another point to note in figure 7 is the fact that there is a point where the field of the magnetic formation is equal and opposite to the earth's field—the *neutral point*. There would be another neutral point at the opposite pole if it were shown. At such a point there is no effective magnetic attraction. Consequently the horizontal compass needle will stand in any position, and the counterweight of the ordinary dip needle will hold it vertical with its north pole upward. Such neutral points are seldom found in field work, but occasionally one can be located when a strongly magnetic formation is found at the surface.

In the area covered by this report the normal declination varies from 6° to 3° east of north and the inclination is about 75° from the horizontal. Determinations made by the U. S. Coast and Geodetic Survey in 1912 give the following:

Place	Eastward Declination	Inclination of Earth's Field from the Horizontal	Horizontal Intensity in Gauss
Ladysmith.....	4° 20.8'	75° 02.4'	.16092
Birchwood.....	5° 44.4'	75° 27.1'	.15592
Park Falls.....	3° 58.0'	75° 27.9'	.15646

Magnetic attraction, like any other force, can be studied as the equivalent of any number of forces producing the same result. It is frequently most simple to consider this force as resolved into horizontal and vertical components, as HR and V shown in figure 20, page 109. Either component may again be divided into local and normal components, as HL and Hn.

*A Method of Using Components.*—By dividing a field into its components it is possible to make a vertical magnetic triangulation to locate the attracting formation and find the depth of glacial drift covering it. The attraction at any point can be considered as being made up of two components; (1) the normal field of the earth, and (2) the local attraction, as described on page 108. If the normal direction and magnitude of the earth's field be determined at some distance from the local attraction, as described on pages 125 to 133, and several determinations of the abnormal attractions across the magnetic formation be made in the same manner, the facts can be plotted as shown in figure 8. In this figure the lines HR give the magnitudes and directions of the attractions at the points observed,

$H_N$  is the normal magnitude and direction of the earth's field. Each force,  $H_R$ , can then be considered as the resultant of two forces, the normal field of the earth,  $H_N$ , and the local attraction,  $H_L$ , due to the magnetic formation. After measuring  $H_R$  and  $H_N$  the triangle can be closed by the line  $H_L$ , which gives the magnitude and direc-

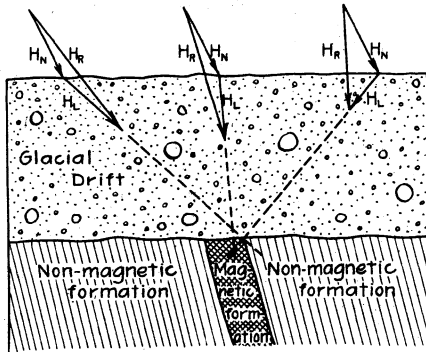

Fig. 8. Finding the depth and position of a magnetic formation.

tion of the local attraction. By extending these last, as shown by the dotted lines, their intersections will locate the cause of the local attraction within a very few feet, both in horizontal position and in depth. As the center of attraction is not at the surface of the formation, but is located a few feet below, this fact will tend to give a somewhat excessive depth. On the other hand, the slight curvature of the local field due to the small effect of the opposite pole will tend to give too little depth, so the two will balance each other more or less completely. The use of this method will make it possible to determine with a single drill hole the kind of formation causing the local attraction—a bit of information that frequently has taken two or three drill holes to discover. This method is most accurate when the drift cover is thick in comparison to the magnetic formation. If the formation is thick and the drift cover thin this method is an unnecessary refinement, as the ordinary instruments can be depended on to show the boundaries of the formation closely enough so that the formation can be penetrated by the first hole.

*Variations in the Magnetic Field of the Earth.*—These are of two orders, those that take place in regular cycles, and those due to magnetic storms. The cyclic variations are of several kinds; the minor variations due to the position of the moon with reference to the earth and sun, which are so minute as to be noted only with the most re-

finer instruments; the daily variations, possibly due to the alternate heating and cooling caused by day and night; the annual variations; and the secular variations.

The *daily variations* in declination at points in the latitude of the Lake Superior region range from 6 to 9 minutes as a yearly average. These are by far the most important of all the variations from the point of view of magnetic exploration. The yearly average for Madison, \* Wis., is given in minutes of arc as follows:

Hour.....	A. M.												P. M.											
	1	2	3	4	5	6	7	8	9	10	11	12	1	2	3	4	5	6	7	8	9	10	11	12
Variation.....	0.1	0.0	0.2	0.5	1.0	1.4	2.6	5.3	3.0	1.7	0.7	2.5	3.5	3.5	2.6	1.6	0.7	0.2	0.2	0.2	0.6	0.7	0.2	0.1
	East												West						East					

It will be noted that the maximum eastward declination occurs at about 8 A. M. and that the maximum westward declination at about 1:30 P. M.

Through the kindness of Mr. R. F. Stupart, Director of the Meteorological Service of Canada and the Toronto Magnetic Observatory, who furnished manuscript copy of the observations, it is possible to present the following table showing the maximum and minimum daily variations for each month for the four years 1911-14. It is fortunate that the magnetic observatory at Toronto is at about the same magnetic latitude as the Lake Superior iron country, so the observations probably give a very close approximation to the variations affecting magnetic field work.

TABLE IV.

Month.	1911				1912				1913				1914			
	I.	II.	III.	IV.	I.	II.	III.	IV.	I.	II.	III.	IV.	I.	II.	III.	IV.
January.....	39.2	5	16	4	27	2.7	2	0	30.3	5.1	4	1	24	2.5	3	0
February.....	58	5.6	16	4	19.9	4	3	0	32.5	3.1	3	1	17.4	2.2	3	0
March.....	57.5	5.3	16	7	29.7	5.6	3	0	26.2	5.3	9	0	30.2	3.7	5	1
April.....	72.4	5.2	14	4	29.3	6.8	12	0	35.9	8.1	5	0	52.2	6.9	11	2
May.....	50.3	8.1	18	4	54.9	8.3	7	2	50	9	13	3	58.9	7	7	1
June.....	51.0	10.1	15	2	37	7.9	9	1	39	10.3	10	1	37.7	7.7	9	0
July.....	37.8	8.8	21	3	27.2	7.6	8	0	24.2	8	7	0	51.1	8.8	15	2
August.....	63.4	8.3	20	2	47	10.6	16	2	21	9.9	12	0	36.8	9.7	24	2
September.....	47.3	6.9	16	3	37.9	7.8	5	1	46.9	7.8	15	1	39.5	6.9	20	2
October.....	53	6.3	9	2	38.6	5.5	4	1	36.1	6.8	9	3	61.5	5.2	12	1
November.....	30.3	5	5	1	37.2	4.5	3	1	24.4	4.4	2	0	24.4	6.7	9	0
December.....	52.5	2	6	2	25.4	3.9	4	0	24.1	3.9	2	0	21	5.1	3	0

\*Principal Facts of the Earth's Magnetism, p. 50.



Columns numbered I show the greatest daily variation in minutes of arc for each month. Those numbered II give the smallest daily variation in minutes of arc for each month. Those numbered III give the number of days in each month in which the variation was more than 15 minutes of arc, and those numbered IV give the number of days in which it was more than 30 minutes.

The total number of days in the four years in which the variation exceeded 15 minutes is 450; of 30 minute days, 68. These totals are divided by months as follows:

Month	15 m. days	30 m. days	Month	15 m. days	30 m. days
January.....	25	5	July.....	51	5
February.....	25	5	August.....	62	6
March.....	33	8	September.....	56	7
April.....	42	7	October.....	34	7
May.....	45	10	November.....	19	2
June.....	43	4	December.....	15	2

The *horizontal intensity* varies on ordinary days not more than  $\frac{1}{4}$  of 1%. In extreme conditions it seldom varies as much as 1%. The *vertical intensity* varies about 1-10 of 1% on ordinary days and about  $\frac{1}{2}$  of 1% on extreme days.

The *annual variation* of the declination is very small, amounting to a total of about 11 minutes of arc at Toronto.

The *secular change* is quite important. The declination at Boston varied from slightly less than 7° west of north, in 1790, to about 12 $\frac{1}{2}$ ° west of north in 1900. The inclination varied from 68 $\frac{1}{2}$ °, in 1722, to 74 $\frac{1}{2}$ ° in 1860, and in 1900 it was 73 $\frac{1}{2}$ °. The secular change of the declination in Wisconsin is very slight, being about 2 minutes of arc per year at present. This is due to the fact that this state is near the line of zero declination. In Rhode Island it amounts to 6.9 minutes, and in Oregon and Washington to 5 $\frac{1}{2}$  minutes per year.

The annual and secular changes are not of such magnitude as to interfere in any way with magnetic exploration.

*Magnetic storms* are irregular disturbances of the magnetic field that may last a few minutes or several days. One such storm caused a variation in declination of 5° in a period of 14 minutes at Cheltenham, Md. The same storm caused a variation of 9 $\frac{1}{4}$ ° in 1 $\frac{3}{4}$  hours in Saskatchewan.\* The ordinary magnetic storm does not effect the declination more than  $\frac{1}{2}$ °. An investigation† of the observations on 18,000 consecutive days at the Kew Magnetic Observatory in England gave the following results:

\*Terrestrial Magnetism, Vol. XIV, pp. 179 and 185.

†Philosophical Transactions, Vol. 20.

Undisturbed days.....	12%
Days having a change of less than 10' in declination.....	66%
Days having a change of 10' to 30' in declination.....	20%
Days having a change of 30' to 60' in declination.....	1.6%
Days having a change of over 1° in declination....	0.4%

*Significance of the Arrangement of Local Magnetic Attraction.*—

The effect upon the general field of the earth of the presence of rocks containing magnetite is shown in figure 7, page 79, and figure 17, page 104. This local attraction is more or less irregularly distributed. Along the strike of a magnetic formation it may be strong in some places and weak in others, but nevertheless the attractions observed on successive traverses will in many cases fall in a line which shows the general strike of the formation. Due to the usual massive character of igneous rocks, the distribution of the local attraction is not so regular as it is in bedded rocks. It is oftentimes possible for an experienced observer to distinguish with a fair degree of certainty whether the given attraction is due to a magnetite-bearing igneous rock, or to a sedimentary rock such as iron formation.

The expression "a magnetic line of good characteristics" is often used in this report. By this is meant a line of moderate attractions—usually varying less than 10° from the dip needle normal—with a single maximum from which the attraction decreases steadily on both sides to the normal. There are all gradations from good to poor magnetic lines and it is often difficult in practice to draw a sharp distinction.

When by careful magnetic observations, either with or without the aid of outcrops, an iron-bearing formation has been traced out, it is not at all certain that iron ore exists in commercial quantities. The only way of definitely proving the existence of ore in a formation thus traced out is careful exploration by test pitting or drilling in favorable places along the general belt indicated by the magnetic attraction. Brooks' statement that "when attraction has been found, the chance of ore is not more than 1 to 50,"\* is highly optimistic if considered as applying to a single drill hole or test pit, but it is pessimistic when applied to a long belt of attraction. The chances are probably better than one in five that merchantable ore exists along the line of magnetic attraction if it is many miles in length, and has good characteristics.

\*Michigan Geol. Survey, 1873, Vol. I, p. 220.

The relation of the maximum local magnetic attraction to the occurrence of ore is exceedingly variable. (See figure 38, page 155.) In some cases it happens that the base of the iron-bearing formation shows the greatest degree of attraction and that the workable ore deposits lie stratigraphically above the line of the maximum attraction. In other cases this may be reversed. In still other cases the strongest local attraction may be directly over the ore deposit. These relations vary with the character of the ore. A magnetite ore body would itself always show the greatest local attraction. A body of hematite ore might be the cause of the maximum local attraction due to the presence of magnetite in it, or the magnetite might be present in larger amounts in parts of the formation away from the ore.

In the Lake Superior region it is generally true that magnetic attractions of *very great strength* are not found immediately over large bodies of hematite. There are some notable exceptions to this, such as the Chapin mine at Iron Mountain, but it is believed that the statement will hold true in a large majority of cases. *However, there is no iron range in the Lake Superior district which does not show at least mild attractions on or near the iron formation. These attractions have been, in nearly every case, of much value in delimiting the range and indicating favorable places to explore.*

These statements indicate the great importance of the slight variations in the earth's magnetic field which are frequently found in association with the parts of iron-bearing formations that have been oxidized and enriched. The importance of these slight attractions has been well exemplified in recent years by the discovery of important belts of iron-bearing formation in the Cuyuna District of Minnesota, where the deflections of the magnetic needle which indicated the presence of the richest belts were only a few degrees different from the normal.

## SECTION II. INSTRUMENTS AND THEIR USES

The instruments ordinarily used in making magnetic observations in the Lake Superior region are the dial compass and dip needle. While these instruments are quite simple, their successful use and the intelligent interpretation of the results obtained require a detailed knowledge of their principles and construction, and very careful handling.

## THE DIAL COMPASS

It is interesting to note that the dial compass was devised by Maj. T. B. Brooks and Prof. R. D. Irving in their work in the Florence and Gogebic ranges. The dial compass consists of an ordinary surveyor's compass with a  $2\frac{1}{2}$ " needle. On the north side of the instrument there is an upright provided with a sight slit, and at the proper height a hole through which a thread is passed and fastened in an eye at the south side of the compass. Around the outer edge of the compass is the hour circle. The graduated circle from which the needle is read is movable, and the normal declination can be set off so that the local variation of the needle, which is due to magnetic rocks, will be read from the normal declination of the needle rather than from true north.

The dial compass is used to show two facts regarding the magnetic field; the direction of the horizontal component at the point of observation, and in approximate fashion, its relative horizontal intensity.

*Principles of the Instrument.*—As its name indicates, the dial compass is a portable sun dial. In the ordinary sun dial the edge of the gnomon is parallel to the axis of the earth, and likewise in the dial compass the indicating thread must be set at such an angle that it also will be parallel to the axis of the earth when the compass is set in a N-S line. This angle varies with the latitude. At the north pole (latitude  $90^\circ$ ) the thread would have to be vertical ( $90^\circ$  from the horizon), and at the equator (latitude  $0^\circ$ ) the thread would have to be horizontal ( $0^\circ$  from the horizon). The angle between the compass plate and the thread must be equal to the latitude of the place where the dial is to be used. The graduations of the hour circle also will vary with latitude, and the instrument makers therefore provide circles for each half degree.

There are three essential elements to the sun dial—the position of the sun, the position of the gnomon, and time. Time is the particular element sought from the sun dial. In the dial compass we use two of the elements, known time and the position of the sun, to set the thread in the correct position pointing toward the north.

*Time Correction.*—In using a watch to get the time for the running of the dial compass, it is necessary to make corrections to standard time to get the local sun time.

*True solar* (apparent time) and *mean solar* are the two kinds of time we must deal with in running the dial compass. *Mean solar*

time is that in ordinary use. In this the year is divided into equal parts, and all mean solar days are exactly the same length. A *true solar day* is the time between two successive passages of the sun across the zenith. On account of the elliptical shape of the earth's orbit and its inclination to the earth's axis these true solar days vary in length, a day in December being nearly a minute longer than one in September. The accumulation of these differences may make the time of the passage of the sun across the zenith (noon by *true solar time*) as much as 17 minutes earlier or later than noon according to *mean solar time*. This difference between *mean solar time* and *true solar time* is known as the "equation of time," and is given for each day of the year in the American Ephemeris issued by the Navy Department and in small memorandum books issued by the makers of instruments. In the United States, standard time is the *mean solar time* of the meridians of  $75^{\circ}$ ,  $90^{\circ}$ ,  $105^{\circ}$  and  $120^{\circ}$  west longitude. Central time is the time of the meridian of  $90^{\circ}$  and in this time zone all of the Lake Superior iron region lies. This is the time used by railroads and jewelers. Since the apparent travel of the sun about the earth is  $360^{\circ}$  in 24 hours, one hour represents a travel of  $15^{\circ}$ . Thus when it is 12 o'clock noon at Greenwich, it is 6 A. M. on the  $90^{\circ}$  meridian.

Local standard time is *mean solar time* for the particular locality considered and differs from central time for all places not on the  $90^{\circ}$  meridian. The longitude of Ladysmith is about  $91^{\circ}5'$  west or  $1^{\circ}5'$  west of the standard meridian of central time. Since  $15^{\circ}$  represents one hour's travel of the sun, this  $1^{\circ}5'$  represents 4.3 minutes and local standard time (or *mean solar time*) for Ladysmith is therefore 4.3 minutes slow. When it is 12 by central standard time, it is 11:55.7 by local standard time.

Local standard time agrees with true solar time only four times during the year. During some parts of the year the sun is ahead of standard time and at other parts of the year it is behind standard time, the change taking place constantly and the difference being given by the "equation of time." When the sun is faster than local standard time, the equation of time must be added to local standard time to give true solar time. When the sun is slower than local standard time, the equation of time must be subtracted from local standard time to give true solar time. This *true solar time* (the "apparent time" of the ephemeris) is what must be used with the dial compass. The equation of time for 1914 is plotted as a curve in figure 9. This shows the magnitude and rate of change of the equa-

tion of time for that year. It will be noted that the change is most rapid in December and January, when it is about 3 minutes per week, and the greatest maximum values are reached in February and November.

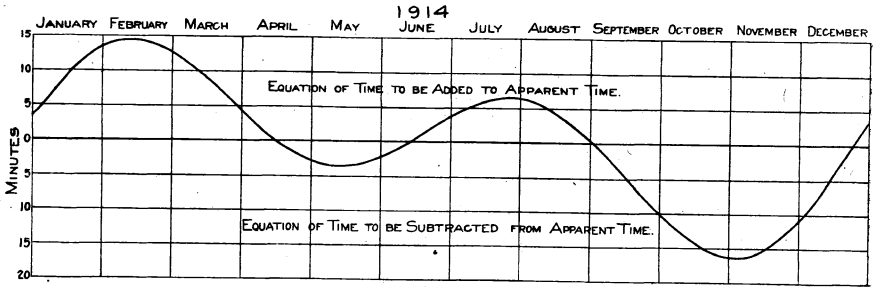

Fig. 9. Curve showing equation of time for 1914. This shows the difference between true solar time and mean solar time.

As an example of the method of applying the equation of time, we will suppose that the *true solar* time (apparent time) is desired for the longitude of Ladysmith on August 27, 1914. If we look on the page for August in the 1914 ephemeris, we find the following:

August, 1914	Equation of time to be added to apparent time
Thursday, 27.....	1 minute, 38.2 seconds
Friday, 28.....	1 minute, 21.12 seconds
Saturday, 29.....	1 minute, 3.64 seconds
Sunday, 30.....	45.78 seconds
Monday, 31.....	27.56 seconds

The column giving the equation of time shows the time to be added\* to *true solar* time to give local standard time (mean solar time). However, we already have the local standard time, which we have found to be 4.3 minutes slower than central standard time, and want to find true solar time. Since this is the reverse of the procedure in the table, instead of adding we subtract the 1 minute, 38 seconds given as the equation of time for August 27th to get true

\*In this month the equation of time is added. In October it would be subtracted, as stated at the head of the column for that month.

solar time; or, instead of subtracting the 4.3 minutes from central time to get local standard time we subtract 6 minutes from central time to get true solar time, the time we use with the compass.

The time used in running a dial compass should be corrected as often as the change in the equation of time makes a half minute difference. In spring and fall when the change in the equation of time is rapid, it amounts to two minutes or more in a week. The best way to correct the time is not to change the watch but to use a correction table as explained on page 94.

It is necessary to have a very accurate watch if time is to be carried for a very long period without opportunity of correcting it. It is sometimes necessary to go many weeks without being able to check the watches with standard time. It is quite necessary, therefore, to be able to determine in camp that the time is correct. The simplest way is to set a dial compass on the north-south line (determined by an observation of Polaris) and check the time before starting to work each morning. This will detect an error of a minute, which is usually satisfactory for dial compass work, but it necessitates staying in camp until the sun is well up in the sky and therefore wastes too much time.

A better and more accurate way to test the watches is to observe the time of setting of some particular star. Before leaving the railroad station for camp the watch should be set exactly on standard time. The first evening in camp a spike or a large nail should be driven into some tree or firm post so that it projects in as nearly horizontal position as it can be set. A stick may be used in place of a nail. This horizontal stick or nail, together with some other fixed point such as a readily identifiable projection on the horizon, a chimney top, or even another horizontal stick nailed to a tree 100 or more feet away, will make a plane of sight. At about ten o'clock that night some easily recognizable star near this plane should be selected and watched until it sinks across the plane of sight. The time when it crosses this plane should be noted. Each succeeding night it will cross this plane 3.93 minutes earlier. If it crossed at exactly 10 o'clock the first night it will cross at 3.93 minutes before 10 o'clock the second night. In a week it will cross at  $7 \times 3.93$  minutes or 27.51 minutes before 10. This gives very exact time with which the watch can be compared as often as desired. To avoid possible difficulties on cloudy nights it is advisable to have the time of several stars.

*Sources of Error.*—From the discussion of time corrections it is apparent that errors in the time used with the dial compass will

make the observations incorrect. Five minutes error in time will make the readings of the declination about two degrees in error. There are also a number of sources of error in the instrument as ordinarily manufactured and adjusted. These are as follows:

1. The level bubbles may not be parallel to the compass plate and consequently the compass will not be horizontal when the bubbles are levelled.

2. The angle of the thread with the compass plate may be incorrect for a number of reasons. The upright on the north side of the compass may not stand vertical, either because the joint is not correctly made or because the string is too tight; the hole for the string may not be directly above the noon mark on the hour circle, or may be at the wrong elevation; and the loop to which the thread is attached at the south side of the compass oftentimes permits of a noticeable vertical variation of the thread.

3. The string may not be put in properly so that when the standard is erected it is not pulled up tight enough to straighten it out.

4. The hour circle may be incorrectly divided.

These sources of error are considerable in amount in many instruments. Their magnitudes can be determined by setting up the instruments on a north-south line, determined in one of the ways described later, and observing the time indicated by the compass each half hour throughout the day. The time shown by the compass will often differ several minutes from that computed from the ephemeris, enough in many cases to make it impossible to get consistent, accurate results with the dial compass by using only the time corrections from an ephemeris. In order to make observations that can be depended upon to show small differences in local attraction, it is necessary to make a correction table by observing the time given by the compass set up as indicated.

Other sources of error that need to be mentioned are magnetic storms (not thunder storms, but disturbances of the earth's magnetic field), and the electrification of the glass over the compass. This latter, particularly in cold weather, is often sufficient to seriously disturb the needle. It is good practice to breathe on the glass frequently on cold days to remove any electric charge that may be present.

### *Establishing the Meridian*

An observation of Polaris is the simplest and most accurate method of obtaining a meridian or true north and south line, since



the axis of the earth points toward the center of the orbit of Polaris. The elongation of Polaris is explained in *B*, figure 10.

*Method 1.*—This method is perhaps the better one, since stormy weather, a hazy atmosphere, or the presence of clouds may interfere with or entirely prevent observation when the star is either at elongation or on the meridian (method 2) and both events sometimes occur in broad daylight or at an inconvenient hour of the night. By this method Polaris may be observed at a convenient time and the meridian calculated. The time when Polaris is at eastern or western elongation on any date may be obtained by interpolation from the ephemeris. For our purposes this table can be used directly (without latitude and longitude corrections). Polaris is easily located since the stars on the outer side of the Great Dipper, Alpha and Beta, *C*, figure 10, are almost directly in a line with Polaris and distant from it about 5 times the space between themselves. During daylight on the day of the observations, select a level spot where an unobstructed view of the north may be obtained. Select this site also with the idea in mind that 200 paces of clear space in a north-south line will be needed to correct compasses. Suspend a stone or plumb bob by a cord about 20 feet in length. A limb of a tree, a crotch, or stiff pole between two trees, serves well as a place of suspension. If a wind is blowing, suspend the bob in a pail of water.

These preparations made, all is ready for the observation as soon as it is dark. A light should be used to illuminate the plumb line just below its support, care being taken to obscure the course of light from the view of the observer.

To make the observation set a 2-foot picket, with a horizontal piece nailed to it as shown in *A*, figure 10, in line with the plumb line and Polaris. Drive it firmly into the ground and set a pin exactly in line with the star and the plumb line, be sure the picket is firmly in the ground and will not spring out of line. Note the exact local standard time. From the ephemeris determine the time of elongation which is nearest the time of observation. Find the exact length of time the observation was taken before or after elongation. Using this time, determine from the curve, *D*, figure 10, the correction or offset,  $x$ , for each foot of the base line,  $l$ . The total offset is  $lx$ . Set off this distance at right angles to the line *PS*, *A*, figure 10, to the east of *S* if Polaris was observed within 6 hours of eastward elongation; and to the west of *S* if the observation was within 6 hours of westward elongation. Having made this offset, set a pin at point *R* or *L*, as the case may be. Then

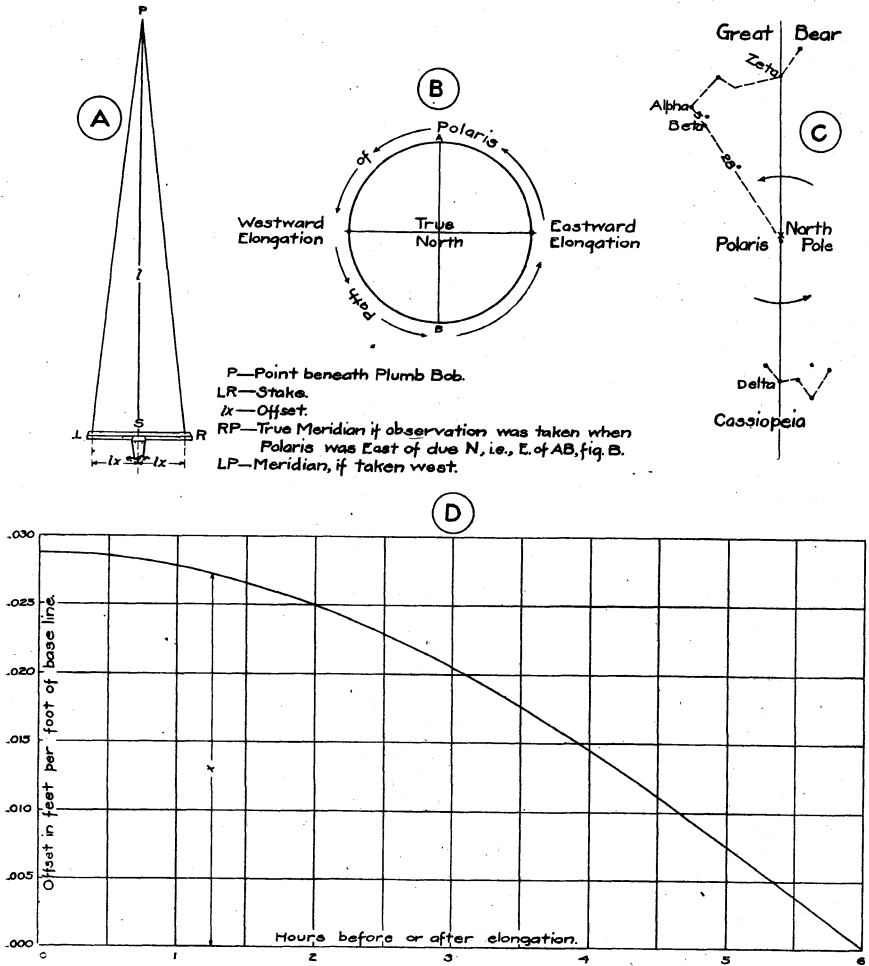

Fig. 10. Diagrams illustrating methods of getting a true north-south line.

sight over the points *RP* or *LP* and extend the true meridian to a distance of at least 200 paces, setting solid stakes to mark the ends of the line, and you are ready to make the compass corrections.

Illustration:

Date, July 25, 1914.

Station, Lat. 45° N., Longitude 90°30' W.

Watch time of observation (central time).....	8:18 P. M.
Correction to central time for longitude.....	:02

Mean solar time (local).....	8:16
Elongation of Polaris Aug. 1st.....	10:54.1
Difference of time for 1 day, 3.92 minutes.	
Difference of time for 6 days.....	23.5

Eastward elongation of Polaris July 25.....	11:17.6
	8:16

Time of observation therefore is before eastward elongation..... 3 hrs. 1.6 min.

From *D*, figure 10

*x* or offset for 1 ft. of base line for 3 hrs. 1.6 min. is .0205 ft.

*lx* or offset for 15 ft. of base line is .3075 ft. or 3.68 in.

Since the observation was taken when Polaris was east of due north, the offset 3.68 inches must be made to the east of *S*, and the true meridian is the line *RP*.

*Method 2.*—To determine the true meridian by observing Polaris at culmination. Figure 10, *C*, shows the principal stars of the constellation, Cassiopeia and Great Bear. As placed, the figure represents relative situations about midnight April 13, 1914, with Polaris at lower culmination and Delta Cassiopeia on the meridian (represented by the straight line) between Polaris and the pole. The diagram held perpendicular to the line of sight directed to the pole, with the right-hand side of the page uppermost, will represent the configuration of the constellations with Polaris near eastern elongation about midnight July 15. Inverted, it will show Zeta of the Great Bear and Polaris on the meridian about midnight October 13.

1. Select that one of the two stars which passes below Polaris at the time of the year when the observation is made. When the star passes the meridian above the pole, it is too near the zenith to be of service. Delta Cassiopeia is on the meridian below Polaris and the pole about midnight April 13 and is therefore the proper star to use

at that date and for some two or three months before and after. Six months later Zeta of the Great Bear will supply its place.

2. Using the plumb line and stake, as described in method 1, place the stake in line with the plumb line and Polaris, and move it to the west as Polaris moves east, until Polaris and Delta Cassiopeia appear on the plumb line together, and carefully note the time by the watch; then by moving the stake preserve the alignment with Polaris and the plumb line, paying no further attention to the other star. At the expiration of the small interval of time given below, the nail on the stake and the plumb line will define the true meridian, which may be extended as described in method 1.

For Zeta of the Great Dipper + 8 minutes.

For Delta Cassiopeia + 9 minutes.

#### *Compass Correction Table.*

In making a correction table for the dial compass, each compass should be set up and sighted upon some distant point known to be either due north or due south. To obtain such a point an observation on Polaris should be made. After ascertaining that the bubbles are parallel to the plate so that the compass can be properly levelled, the compass should be gone over carefully to note that the string is properly tightened and in perfect condition, that the upright is in its proper position and that the lower end of the thread is in such position that the thread points toward the east-west line on the hour circle when viewed from the side. Then comparisons of watch and compass time should be made each half hour from 7:30 A. M. to 5 P. M., the period of the day during which the dial compass can be used. It is most satisfactory to select times for comparison when the shadow of the thread exactly coincides with some division of the hour circle and then to observe the corresponding time of the watch. This is more accurate than taking the even minute or 5-minute period of the watch and estimating the minutes and fractions on the hour circle of the compass. A time card like the one shown below is then made for the compassman's use.

## COMPASS NO. 1.

Time corrections to be added to watch time to get correct time for compass.

Central Standard Time	August 27, 1911	
	Correction	
8.14.....	+5½	minutes
8.55.....	+6½	minutes
9.59.....	+6	minutes
10.28.....	+6½	minutes
10.58.....	+6½	minutes
11.28.....	+7	minutes
12.36.....	+7½	minutes
1.05.....	+10	minutes
1.30.....	+10½	minutes
2.00.....	+10½	minutes
2.29.....	+11	minutes
3.00.....	+10½	minutes
3.30.....	+10	minutes
4.22.....	+8½	minutes
4.34.....	+8½	minutes

It so happened in this particular instance that the correction at 8.14 was the same as the computed correction to be added to central standard time. If the compass had been free from instrumental errors this same correction would have held for the whole day. Without the use of the correction table the time error would have been  $5\frac{1}{4}$  minutes at 2:30 and the observed declination of the needle would have been wrong by about  $2^\circ$ .

The curves shown in figure 11 were made in 1911 and show the variation of the compasses in the Florence district. These curves are given for different compasses to show the variation of individual instruments, and for different times of the year to show how the same compass will change as threads are renewed and as the difference between local standard time and sun time changes. It should be borne in mind that if there were no instrumental errors these curves would be straight horizontal lines.

A new correction table should be made whenever it is necessary to insert a new thread or when any other change in the instrumental error is suspected. The table of corrections should be changed from day to day to keep step with the change in equation of time. As an example, consider the table of corrections made for August 27th above. In the ephemeris we find that on August 29th the equation of time has changed 34 seconds and the corrections for August 27th must be increased by that amount. On August 31st the equation of time has changed 1 minute, 10 seconds from its value on August 27th, so we increase our corrections by one minute (the 10 seconds being negligible for dial compass use). This procedure should be followed until a new correction table is made.

MINERAL LAND CLASSIFICATION

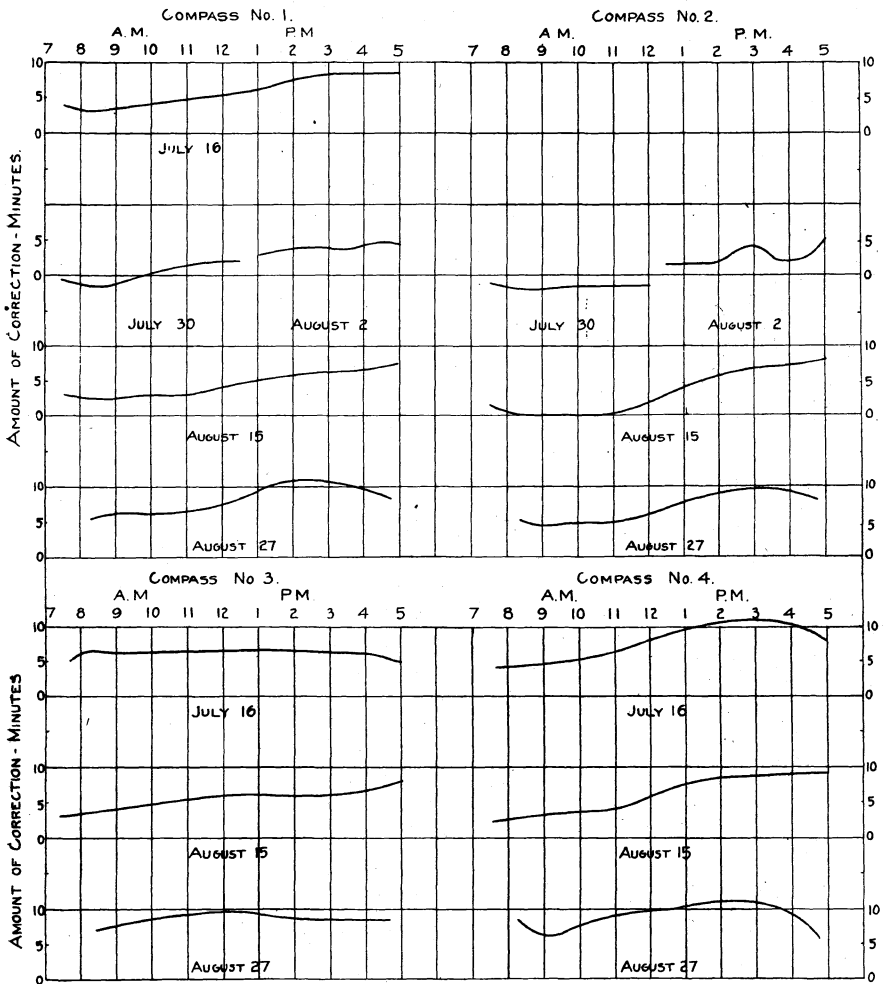

Fig. 11. Compass correction curves showing how different compasses varied on different dates.

*General Accuracy.*—If a correction table is made with reasonable frequency, and the compass is kept in good condition, the readings of the declination should be accurate within  $\frac{1}{2}^{\circ}$  in good circumstances, and with the rare exceptions of unusual magnetic storms the error should never be more than a degree.

### THE DIP NEEDLE.

*General Description.*—The dip needle consists of a thin, light, magnetic needle swung on a pivot, the ends of which rest in jewelled cups. If the pivot were exactly in the center of gravity and the bearings were frictionless, this needle, when in the plane of the magnetic meridian, would show the exact inclination of the magnetic attraction at the point of observation. One form of dip needle (the Norwegian) is provided with a universal joint which permits it to swing in all directions. This form, however, has not met with as much favor in the Lake Superior iron country as the ordinary form with fixed bearings which can swing only in one plane.

There are two forms of dip needles with fixed bearings, depending on the way in which the counterweight is applied. In the ordinary form it is applied near the south end of the needle and is symmetrically placed with regard to its long axis. The Gurley instruments of this form are balanced so that the needle is horizontal and reads zero at Troy, N. Y. This form is always held so the needle is in the plane of the magnetic meridian. In the second form the counterweight is applied underneath the pivot (on the short axis of symmetry) and this form is usually (though not necessarily) observed in a position perpendicular to the plane of the magnetic meridian. When held thus its position depends only upon the variation in intensity of the vertical component of the magnetic field. The position assumed by either form of needle, when held parallel to the meridian, depends upon both the horizontal and vertical components of the magnetic field.

The difference in action of the two forms lies in the fact that the turning effect—the turning moment—of the counterweight increases with increase in dip of the needle in the form having the counterweight below and decreases with the increase in dip in the ordinary form.

The dip needle is more sensitive than the dial in detecting small changes in the earth's field. As ordinarily used it gives no information as to the direction or intensity of the earth's field. Its readings

are most useful to compare with other readings of the same instrument, or of instruments having approximately the same normal reading.

The construction of the dip needle is necessarily delicate and this makes it very difficult to keep in good condition. It is hard to prevent moisture and dirt from getting inside the case, and once inside they are very likely to get into the jewelled bearings. The moisture causes rust pits in the ends of the pivots, destroying the true rounded form necessary for accuracy. The dust introduces friction which very seriously impairs the accuracy of the instrument and "blocks the wheel," as indicated in figure 12, making it impossible to take a series of readings in one spot with an instrument in poor condition without getting occasional differences of as much as 10 or 15 degrees, and oftentimes of 2 to 5 degrees.

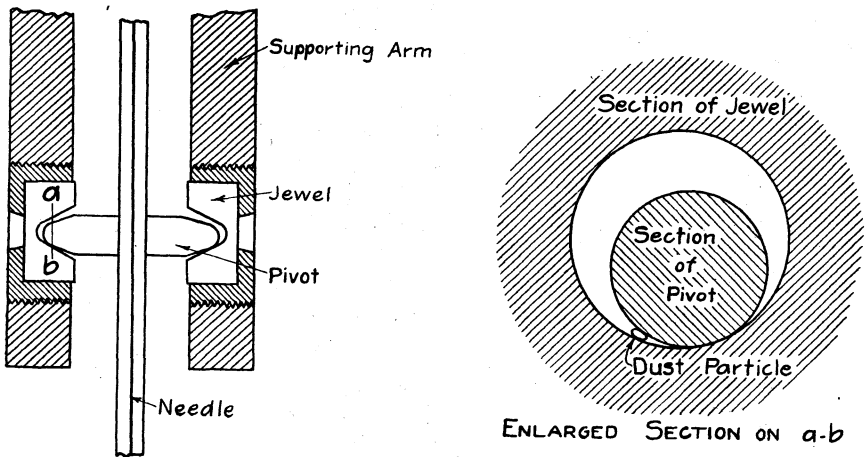

Fig. 12. Enlarged sections showing the action of the dip needle and the effect of dust in the jewels.

This difficulty and the impossibility of definitely interpreting its readings have caused it to be relied upon somewhat less than the dial compass until recent years.

*Principles of the Dip Needle.*—In order to use the dip needle intelligently it is necessary to understand its construction and the principles on which it acts. There are two constructional features that are of great importance. The first of these is the mounting—the way in which the pivot acts in its bearings. The manner in which the pivot rests in the jewels is indicated by figure 12. It appears



from this figure that it is not a needle-point bearing, as in the horizontal compass, but there is more or less rolling movement in the action of the needle. This feature is exaggerated in the figure to make it more easily appreciated. The nearer the point of the pivot comes to being a true point, the better and more sensitive is the dip needle's action.

The second constructional feature is the manner in which the needle is stopped from swinging. This is done by two brass clamps with holes through which the pivots pass. To free the needle these are pulled apart by a wedge which is raised by a small button. This button is pushed down to drop the wedge and allow the brass strips to pinch the needle and stop it. In use dirt accumulates about the tiny rod connecting the wedge and the button so that it sticks, and the wedge goes down with a snap which allows the clamps to batter the pivot ends into the jewels. This battering soon dulls the pivot points and destroys the delicacy of the instrument. To avoid this difficulty, as well as to provide a better means of holding the instrument and to prevent dirt and moisture from getting inside the case, a new method of operating the clamps by a screw was devised and used in the area covered by this report. This was much more satisfactory than the old form. The two forms are shown in figure 13.

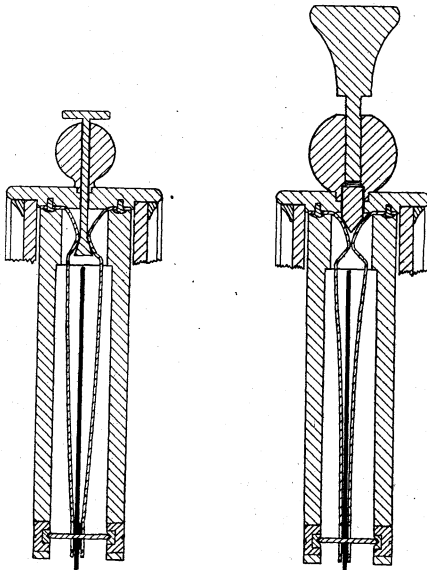

Fig. 13. Old (left) and new (right) methods of operating the clamps that hold the dip needle from swinging when not in use.

In addition to the two constructional features described above it is necessary to understand the effect of the counterweight and of magnetic fields of different intensity and inclination. The position of rest assumed by the dip needle is dependent upon three factors: (1) the weight and position of the counterweight, (2) the inclination and (3) the intensity of the magnetic force. The two forces act at a distance from the pivot of the needle. The counterweight is at the distance  $a$  and tends to pull the south end of the needle downward. Its turning moment is the product of the weight and the effective distance from the pivot. From figure 14 it is apparent that the moment is  $cy$ , that  $y$  decreases as the needle departs from a horizontal position when the counterweight is on the south end, and that  $y$  increases as the needle departs from the horizontal when the counterweight is below the needle.

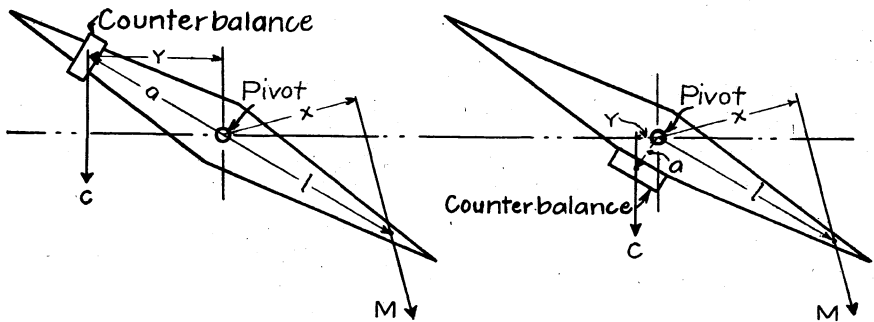

Fig. 14. The two forms of dip needle, one with counterweight on the end and the other with the counterweight below the needle.

The turning moment of the counterweight is opposed to the turning moment of the magnetic force. The magnetic field pulls upward on the south end and downward on the north end of the needle. For convenience these forces are shown in figure 14 as the single force  $M$ . The magnitude of this force depends upon the distance— $2l$ —between the poles of the magnetic needle, its pole strength  $m$  (the product  $2lm$  being the *magnetic moment* of the needle) and the strength of the earth's field  $H$ . The force  $M$  shown in the figure is the product  $2lmH$ . The turning moment of this force is  $Mx$ , and it tends to pull the *north* end of the needle downward. The turning moment of this force is evidently greatest when the needle is directly across the earth's field and  $x=l$ .

For a needle which has a normal reading  $12^\circ$  below horizontal in the normal field at Madison (Intensity= $.75$  gauss, Inclination= $76^\circ$ )

the counterweight was weighed and found to be 22 milligrams. The distance  $a$  was measured and found to be 1.9 centimeters. With these constants known it was possible to compute the moment of the counterweight for any position, and hence the moment of the force  $M$  needed to balance it. Conversely it was possible to compute a counterweight for this needle which would give any desired reading for any field selected.

From these data a series of curves, figure 15, were drawn. These show the positions this particular needle would assume for all variations of the intensity from 0 to 1.4 gaussses, and for angles of inclina-

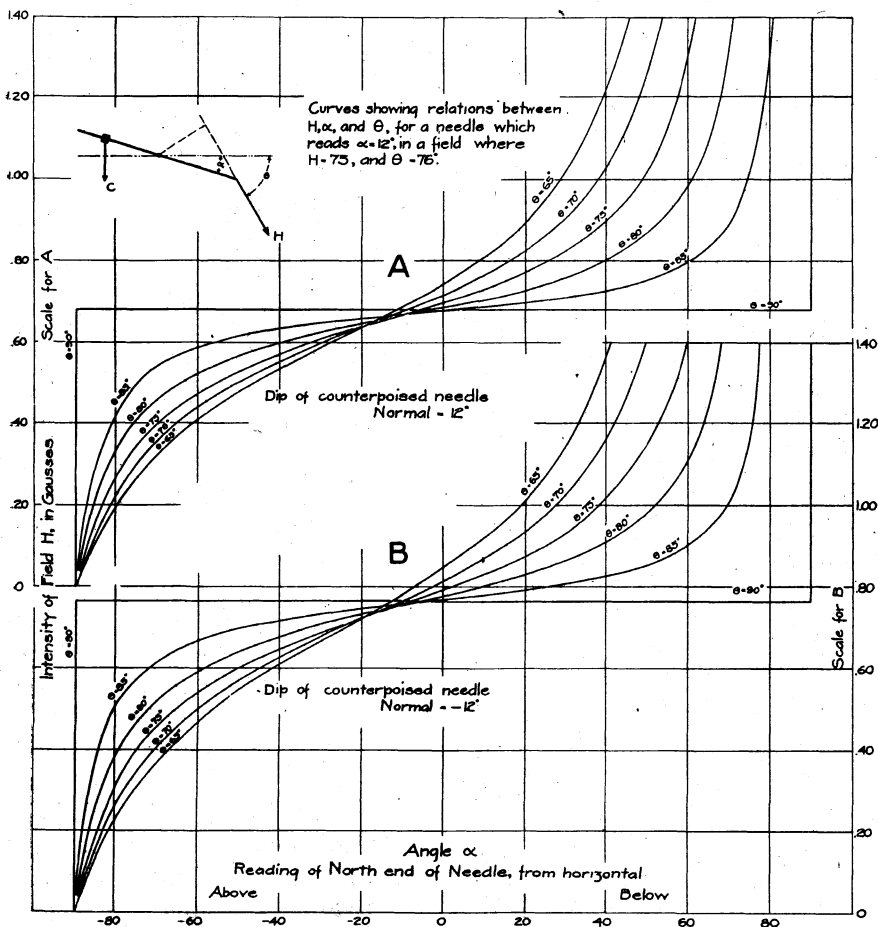

Fig. 15. Curves showing position assumed by two dip needles with different counterweights for various intensities and inclinations of the magnetic field.

tion varying by  $5^\circ$  intervals from  $65^\circ$  to  $90^\circ$ . The ranges of angle and intensity were chosen to include all intensities and all degrees of inclination ordinarily found near magnetic formations. The curves in *A* show the dip needle readings when the needle is counterbalanced so as to have a reading  $12^\circ$  below horizontal in the normal field at Madison, and those in *B* are for the same needle with a normal reading of  $12^\circ$  above horizontal—nearly at right angles to the direction of the earth's field.

These curves give a complete and definite picture of the behavior of the ordinary dip needle under the conditions usually met with in the field. From *A* it appears that a positive dip of  $20^\circ$  may be due to any inclination of the field from  $65^\circ$  to  $90^\circ$  but cannot indicate an intensity greater than .91 or less than .69 within that range of inclinations.

In the space included between the dips of  $+2^\circ$  and  $-24^\circ$  the change in the dip needle reading is about  $12^\circ$  for a 10% change in the intensity, and an equal amount for a  $20^\circ$  change in the inclination of the earth's field. Thus 10% change in intensity may be said to be the equivalent of  $20^\circ$  change in inclination so far as effect upon the dip needle is concerned. The intensity changes found in areas of local attraction vary 10 times this amount and the total change in inclination ordinarily found is probably less than twice  $20^\circ$ . Thus for ordinary fields the changes in *intensity* may be said to have at least 5 times the effect of changes in *inclination* upon the dip needle readings.

From the curves it is apparent that the dip needle is most sensitive to intensity changes near the center where the curve approaches a horizontal direction. Toward the ends of the curve the change in inclination has a relatively greater effect. From a comparison of curves *A* and *B* it is evident that there is comparatively little difference in slope of the curves for the differently counterweighted needles, but that the slight difference that does exist favors the needle whose normal is  $12^\circ$  below the horizontal—the *A* curves. Therefore the needle with the  $12^\circ$  normal should be slightly more sensitive than one with a normal of  $0^\circ$ , or  $-12^\circ$ .

Figure 16 shows graphically the effect upon the dip needle of changes in intensity and inclination. In this figure the turning moment of the counterweight is represented by a force acting upward at the point where the force *M* acts downward. The moment of the counterweight varies with the position of the needle as indicated. The position assumed by the needle is the one in which the two turn-

ing moments exactly counterbalance each other, or, in other words, the position in which the resultant of the two forces passes through the pivot and so has no lever arm and no turning effect. Intensity is indicated by the lengths of the lines  $M$  representing the magnetic force, and inclination is represented by their directions. The needle at the left shows the effect of change of inclination with no change in intensity, and that at the right shows the effect of change in intensity with no change in inclination.

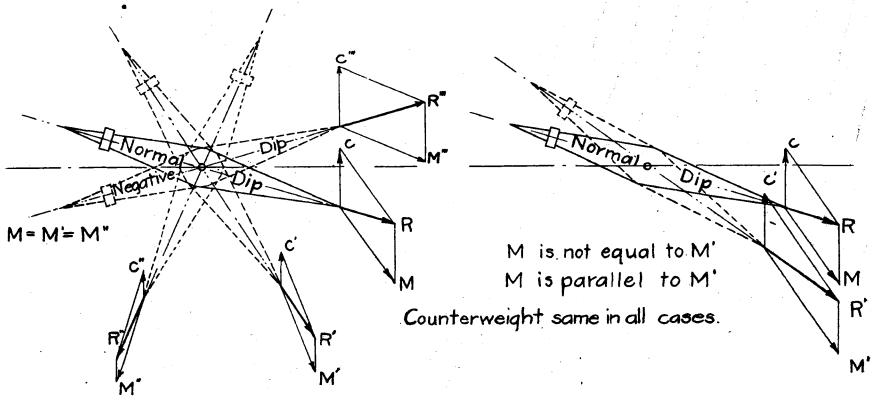

Fig. 16. Showing the effect upon the dip needle of changing the inclination, leaving intensity constant (left); and of changing intensity, leaving inclination constant (right).

A general idea of the positions assumed by a dip needle in crossing a strong magnetic formation is given in figure 17. In this figure the dip needle is represented by the heavy arrows. The vertical arrows represent the effect of the counterweight which tends to pull the north end of the dip needle upward. The lower arrows represent the inclination and intensity of the earth's magnetic field at each successive point of observation. The figure explains why two positions are sometimes found in which the needle will dip  $90^\circ$ .

Another important deduction from the curves of figure 15 is that negative readings—those in which the north end of the needle goes above its normal position—are due almost entirely to lowering the intensity of the field. It is very doubtful if there exists in the Lake Superior region a magnetic formation whose effect would be strong enough to reverse the direction of the earth's field (and so actually attract the south pole of the needle and repel the north) except for distances of a very few feet. If such a case were found the dip needle

would behave as it would in a normal field if the counterweight were on the *north* end,—in other words, it would come to rest in that small part of the circle lying between the *inclination* direction and the nearest vertical.

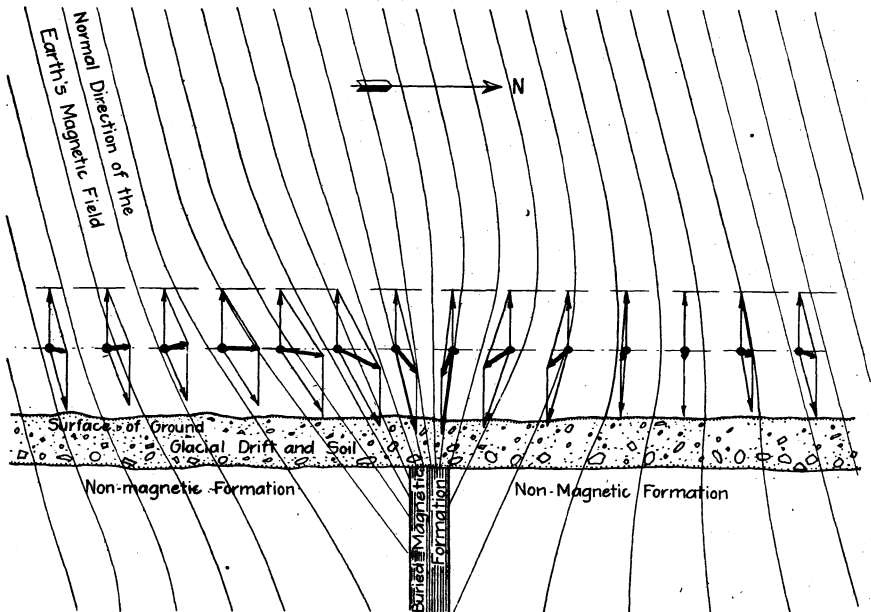

Fig. 17. The positions which the dip needle (represented by the heavy arrow) takes in going over a strongly magnetic formation. Each position is the resultant of the vertical, upward pull of the counterweight and the (usually) inclined, downward pull of the magnetic field.

The discussion of figure 15, it should be remembered, applies specifically to the one needle whose magnetic moment and counterweight were determined. As manufactured these needles vary more or less in both constants. It is therefore important to consider the effect of these individual variations.

The relative magnetic moments of needles can be determined as described under the succeeding head. Differences in the behavior of apparently similar needles can usually be understood from such a comparison. Figure 15 shows how needles with different counterweights and the same magnetic moment may give widely different readings for the same change in magnetic field. Varying the magnetic moment changes the magnitude of the force  $H$  in the figure so that by this method the  $A$  curves could be altered to fit the  $B$  curves.

If two similar needles with different magnetic moments have their counterweights so adjusted as to give the same normal reading they will be effected in the same degree by changes in the earth's field.

*Determination of the Relative Strengths of Magnetic Needles.*—In the field use of the dial compass and dip needle it is sometimes desirable to know whether the magnetic needle of a particular instrument has lost any considerable part of its strength. A very simple method of doing this is to set first one and then the other of the needles to be compared in the position *N-S* in figure 28, page 127, and a sensitive dial compass with the needle swinging free, in the position *n-s*. The distance between the centers of *N-S* and *n-s* should be exactly the same in each instance and it is convenient to make it about one foot. If the first needle is placed with one end toward *n-s* it will cause a certain deflection. If the other end is then turned nearest to *n-s* the deflection will be in the opposite direction. Half of the total angle between the two positions is taken as the angle *a* in the formula. The angle *a* is then determined for the second needle of the two to be compared. The magnetic moments, *M* and *M'*, of these two needles then bear the ratio to each other expressed in the formula

$$\frac{M}{M'} = \frac{\tan a}{\tan a'}$$

It is convenient to remember that the natural tangents of angles of 6° or less are directly proportional to the angles and can be found by multiplying the numbers of minutes of angle by 0.00029. Thus the natural tangent of 2° = 120 × .00029.

*Sources of Error.*—Sources of error in dip needle observations are:

1. The manner of holding. It is very necessary that the needle always be held in exactly the same manner, read from the same side, and with the same side of the needle toward the observer. In this work the needle was always read when the observer was facing the east (magnetic) side of the needle.

2. Irregularity in pivot or jewels. If the pivot or jewels are not properly shaped there may be considerable irregularity in the readings obtained. This irregularity can be avoided by testing the instruments carefully and using only those which give consistent results.

3. Dust and moisture on the pivot or in the jewels are evident causes of error, the same in effect as irregularities in pivots or jewels.

4. The gradual loss of magnetism in the needle may make a no-

ticeable difference in readings made at long intervals of time, but the change in a single field season is not likely to be worth considering unless some accident has happened to the instrument.

5. Electrification of the glass from friction, particularly on cold days, is a very common occurrence. It is a good thing to form the habit of breathing on the glass before every observation on cold days to remove any possible charge of electricity that may be present.

6. Magnetic storms will cause variations in the readings, but these will not be consistent in any way and the careful observer is not likely to be misled by them.

*Repairing Dip Needles.*—Owing to the ease with which the pivots of the dip needles become worn and blunted it was found necessary to devise small repair outfits with which they could be repointed in camp. The chief piece of apparatus was the small lathe shown in figure 18. The glass faces of the instrument were put in with soft

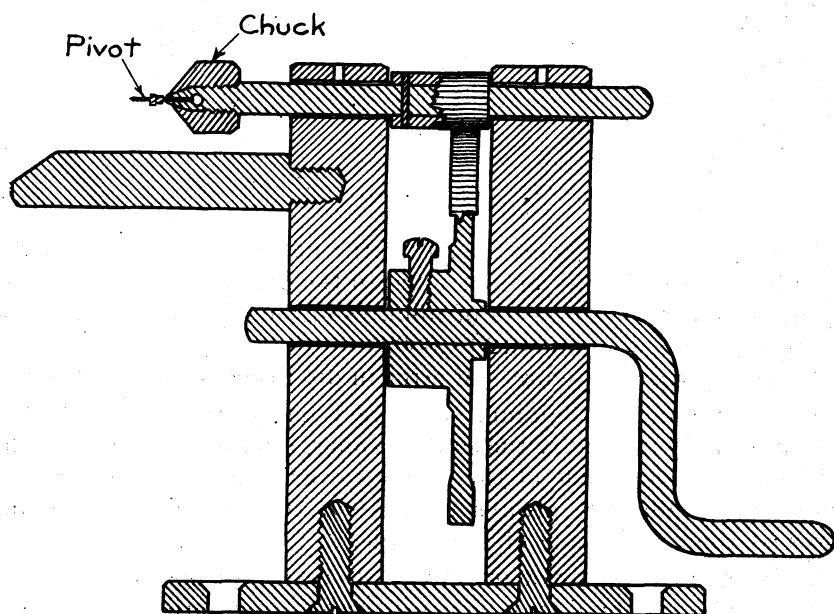

Fig. 18. Small lathe for repairing dip needle pivots. Actual size.

wax to facilitate removal. One jewel was unscrewed, the needle removed, and the pivot screwed out of it with a small pair of pliers provided for the purpose. This pivot was put in the chuck and sharpened with a fine hone which rested on the projecting arm. The



length of this arm was such as to give the proper angle to the point. After sharpening the point was polished with a piece of very fine emery-powder paper pasted to a flat piece of wood. It was found that a little practice enabled a careful man to put a better point on a pivot than it had when it left the instrument maker. The pivot was then screwed into the needle and inserted in the instrument. The jewel was screwed back into position very carefully so the end of the needle could be moved up and down a barely noticeable distance as the instrument lay on its side. A strong hand lens was used to see that all parts were entirely free of dirt and finger prints. The instrument was then tested to see that it swung freely and gave constant readings when held in the usual manner. If not, the jewels were adjusted until it did. If the normal reading was not satisfactory it was changed by using a very fine file on the brass rivets at either end.

*Method of Using.*—To get consistent results with the dip needle is extremely difficult and requires intelligent care and use of the instrument, especially if it is desired to detect small variations in the attraction. The dip needle is so likely to get out of order that it must be constantly checked and tested to make sure that it is reading properly. The men who took dip needle readings in this area checked their instruments each morning just before leaving camp and each evening immediately on returning. The observer's complete field outfit, including his collecting bag, hammer, water bottle, and whatever he usually carried in his pockets, was in its usual place and the instrument was always held at exactly the same place in camp and in the same direction. If an instrument failed to give the same dip morning and night it was laid aside to be cleaned and re-adjusted.

The usual method of holding the dip needle in making observations is by the large bail. However, this is not at all satisfactory if there is any wind, as it is necessary to have the needle quite still while making an observation. With the new form of needle devised for this work the instrument was suspended by the specially formed screw head shown in figure 13, page 99. This proved a very satisfactory means of holding it steady. Level bubbles were provided in all dip needles to make it possible to hold them more accurately.

#### SIGNIFICANCE OF MAGNETIC OBSERVATIONS.

An excellent mathematical paper on the significance of magnetic observations is published in the *Crystal Falls Monograph*.\* The

\*Mon. XXXVI, U. S. G. S., Chapter 2, Part II, by H. L. Smyth.

present discussion is based chiefly on observation and experiment and written with the fact in mind that the average student of geology is not sufficiently familiar with mathematics to understand a mathematical treatment of the subject. Those who wish to study the matter thoroughly should not fail to read Smyth's discussion. Many statements in this chapter are taken from his paper.

In the beginning it may be well to state a few elementary things that should be borne in mind. First, it must not be forgotten that magnetic attraction is seldom uniformly distributed throughout an iron formation. The attraction is always more or less "bunchy," strong in some places and weak in other places, but in developing type cases we must assume, for simplicity, that the attraction of an iron formation is substantially uniform along the strike and leave the modifications to be made by the observer in the field. In the case where the attraction is uniform, its action, considered apart from the earth's field, is always in a direction perpendicular to the line of strike of the formation, as shown in figure 19 after Smyth. The shaded portion inside the circle of radius  $x$  is that part of the formation close enough to the observer at  $A$  to attract the needle an appreciable amount, and it will be noted that half of the attracting area is on each side of the perpendicular to the strike of the formation. The arrow  $a$  represents the north horizontal component, the arrow  $b$  the direction and intensity of the local attraction (perpendicular to the strike), and the resultant arrow  $c$  shows the position of the needle, and its length shows the intensity of the resultant.

Second, it will avoid confusion to remember that *at any point there is but one magnetic force, having but a single direction and a definite magnitude*; that while we speak of the horizontal component of the earth's field combining with the horizontal component of the local attraction to give a resultant which is the direction of our horizontal needle, what we really mean is that we are dividing up the horizontal component of the single line of force at that point and considering it as two forces for convenience of explanation, viz., the usual horizontal component of the earth's field and a horizontal component normal to the magnetic line. Figure 20 gives a diagrammatic representation of this. The single line of force at any point is represented by the line  $MM$ . The vertical component of this force is shown by  $V$ . The horizontal component is the direction assumed by the needle and shown by the force  $HR$ , usually spoken of as the horizontal resultant and divided into two components  $HN$  and  $HL$ , the

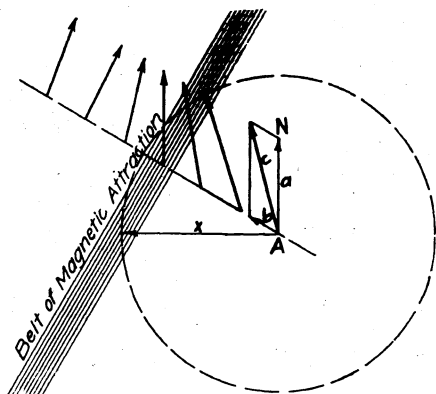

Fig. 19. Showing the effect of a magnetic formation on a dial compass needle at A and successive points in a line across the formation.

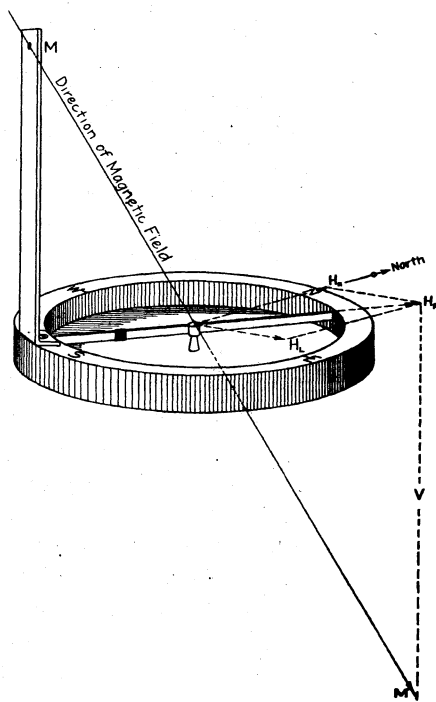

Fig. 20. The components of the earth's magnetic field usually considered are the vertical (V) and the horizontal (H<sub>R</sub>). The horizontal component is often further divided into north (H<sub>N</sub>) and local (H<sub>L</sub>) components.

north component and the local component. It is a common thing to hear persons who have a wrong idea of this insist that their favorite compass is only slightly affected by local attractions—that it will “point true” regardless of whatever local attraction may tempt it from its “straight and narrow path.”

With these two things in mind we can proceed to discuss the interpretation of our magnetic readings.

Properly made magnetic observations give us more or less definitely four important items of information:

1. Character of magnetic rock, bedded or massive.
2. The strike of bedded magnetic rocks.
3. The relative intensity of the local attracting force.
4. The direction of dip of bedded magnetic rocks.

1. *Character*.—Igneous rocks which show magnetic attraction do not usually possess regular linear structure that persists for any great distance. The magnetic attraction is usually, therefore, much more irregular than that of bedded rocks. This is not always true, however, and other evidence, as outcrops and character of the glacial drift, may be used to verify the indications of the magnetic needle.

2. *Strike*.—From dial compass readings on a single transverse crossing the formation we can correctly infer the general direction of strike of a magnetic formation in all cases except those that are very “bunchy” or that show weak attractions combined with an east-west strike. Figure 21 shows the characteristic difference at a glance. The strike is determined more definitely by connecting on adjacent traverses the points of no deflection on the dial compass curves, or the points of maximum dip needle readings. Such a line is referred to as a *magnetic line*. Traverses should be made across the magnetic formation at intervals close enough to detect all the changes in strike that are desirable for the purpose in mind.

3. *Intensity*.—In the case where the strike is east-west there is no change in direction of the horizontal needle south of the formation so long as the attraction is evenly distributed. Just north of the formation the pull may be strong enough to reverse the needle and cause it to point south for a short distance. If the attraction of the formation is not strong enough to reverse the needle its horizontal component is directly opposed and the intensity is less than normal. It is frequently of value to measure the relative horizontal intensity in such situations, particularly if a dip needle is not used. The period of vibration of the compass needle can be used for this. The normal period of the compass should first be observed in a place known to

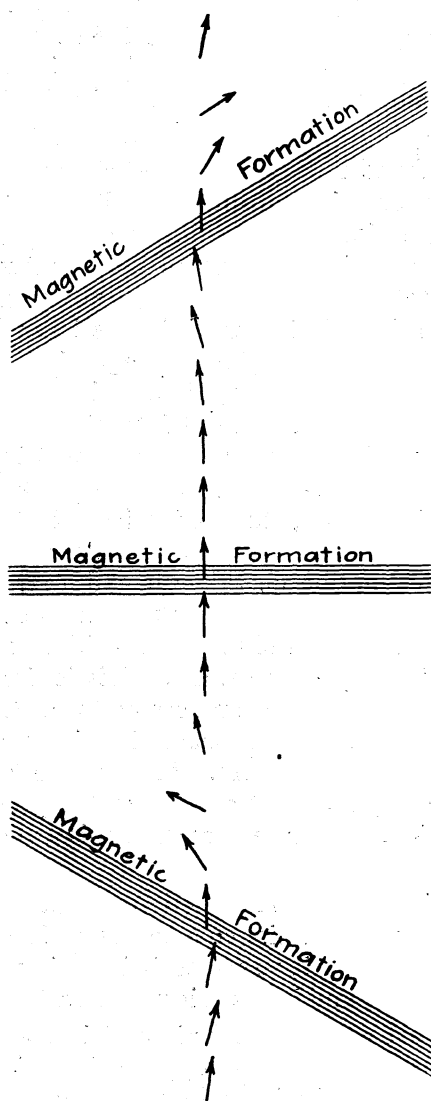

Fig. 21. Showing the effect of the strike of a magnetic formation on the dial compass needle.

be free from local attraction. This was found to give, for the compasses used, about eleven swings—half vibrations—in 22 seconds. When the intensity was greater than normal the time of swing was shortened, in some cases to 11 swings in  $16\frac{1}{2}$  seconds. When it was less the time was increased. The relative intensity can also be measured in the same manner by observing the time of the swings of the dip needle.

The intensity of the field varies inversely as the square of the period of vibration for swings of small amplitude. There is too much friction in the suspension of the ordinary compass needle to permit a sufficient number of vibrations when the amplitude is small, but in vibrations of large amplitude the error is not great enough to prevent the determination of differences in the intensity that may be very useful in the careful following of magnetic horizons. The following instance taken from the field work in Florence county will serve as an illustration of the use of intensity tests, see figure 22. A magnetic horizon with the usual northwest strike was being followed by closely spaced traverses. When the compass was northeast of the magnetic horizon, the declination was westward as is the usual case. As successive traverses were made a final one showed a strong westward declination on the east and a strong eastward declination on the west part of a traverse exactly as though a magnetic line had been crossed, but an observation of the period of vibration showed the intensity to be very weak. This indicated that the attracting mass was south of the compass and that the magnetic belt either made a sharp turn from its usual direction or that there was a large magnetic mass located there. Another traverse showed that the line turned sharply and that a fold was the probable cause. An element of geological structure was thus discovered in a district showing no outcrops.

4. *Dip*.—The dip of bedded magnetic rocks has a very noticeable effect on the readings of the dial compass and dip needle, and when this effect can be properly interpreted it is an important aid in determining the structure and in planning explorations for iron ore.

In order to see just what effect various strikes and dips of a magnetic bed would have on the readings of the horizontal needle, an apparatus was constructed with a sheet of heavy tin as the "magnetic formation" and a series of experiments made. The method of procedure as well as the construction, (figure 23) is given so that those who wish to use the results may have an idea as to their accuracy. It was considered that extreme accuracy was unnecessary, as

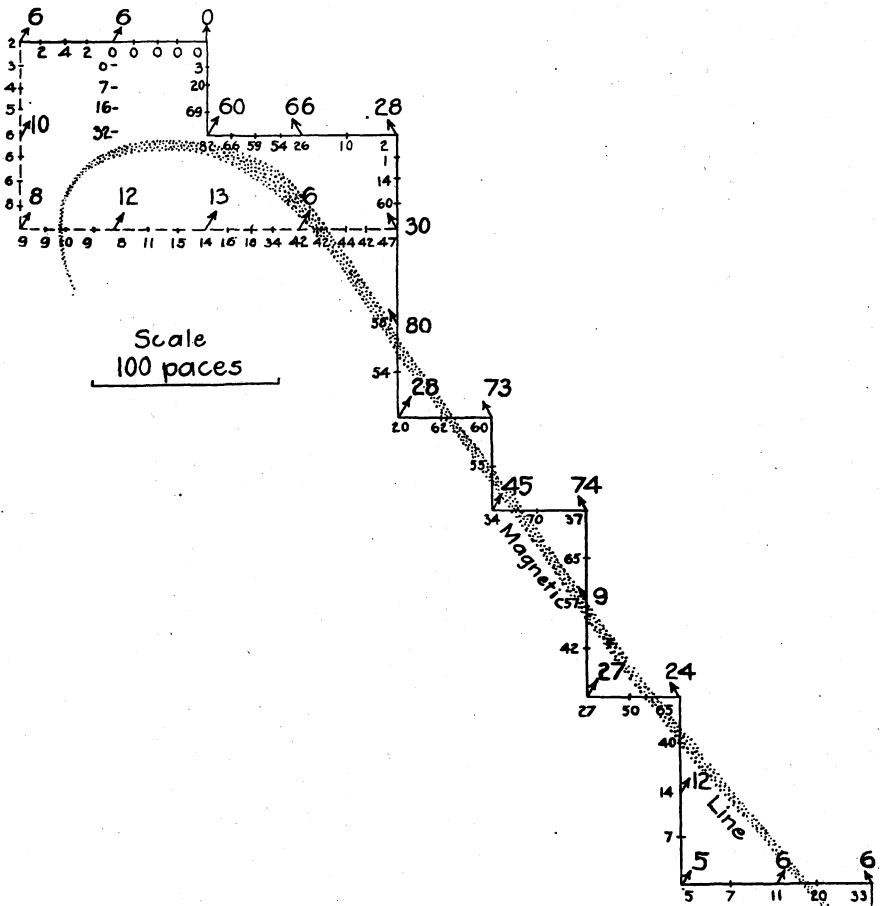

Fig. 22. Map of a magnetic line in Florence County traced by dial compass (large figures) and dip needle (small figures) observations, and showing how its apparent northwest continuation was shown to be wrong by observing the magnetic intensity.

natural conditions in the field are so variable. The accuracy desired was that sufficient to give curves typical of the various dips and strikes.

First a place to conduct the experiment was found—not an easy task in a building—where the direction of the local field did not vary more than one degree in the four feet over which observations were taken. In order to avoid the magnetic effect of nails a single plank of the proper length was used. From the under side of this a sheet of tin 20x28 inches was suspended by a wood frame fastened with copper nails. It could be set at various distances and angles below the surface of the board—the different depths representing different thicknesses of glacial drift covering over a magnetic formation.

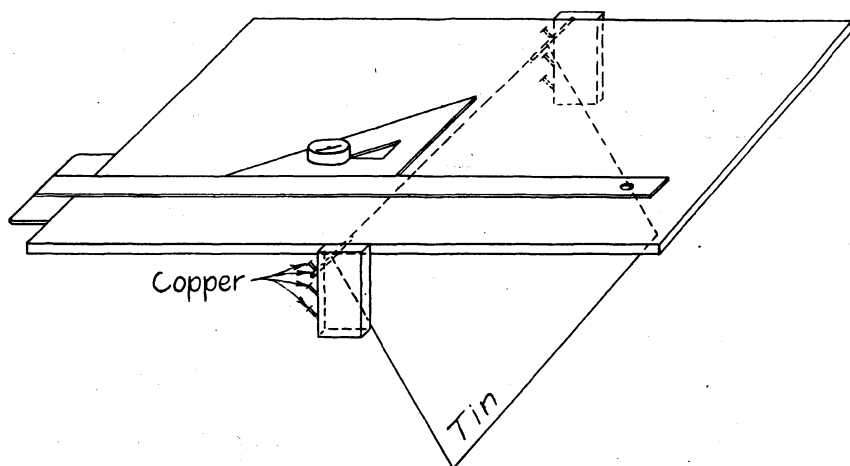

Fig. 23. Apparatus used in testing effect of dip and strike on the dial compass needle. The results are shown in figures 22, 23 and 24.

A long wood T-square was provided, and a small compass, divided to  $2^\circ$  (and estimated to half degree), was fastened with wax to a wood triangle, so that the north-south line was at right angles to its base. The board was oriented so that the "strike" of the tin was parallel to the local magnetic field, and a series of readings was then made by sliding the triangle along the T-square and noting the declination of the compass in many positions. The positions of maximum and zero declinations were very carefully determined by repeated tests. Fifteen series of readings were taken with the tin striking N-S (magnetic) as follows: top of tin 2" below compass, dips  $30^\circ$  W.,  $60^\circ$  W.,  $90^\circ$ ,  $60^\circ$  E., and  $30^\circ$  E.; top of tin 5" below compass, same dips; top of tin 8" below compass, same dips.



Similar series of readings were then made with the "strike" of the tin changed to N.30°W. and then to N.60°W. The readings were plotted as curves and are given in figures 24, 25 and 26. The essential relations of the readings are given in tables V, VI and VII. Observations for strikes east of north were not made, as it was assumed that they would be similar to those with strikes west of north.

TABLE V.

*For Strike N-S.*

Dip	Depth	Ratio No. 1		Ratio No. 2
		Dist. of E. M.* from 0	Dist. of W. M. from 0	E. M.*
				W. M.
30° W.....	2"	.62		.68
	5"	.75		.40
	8"	.78		.48
60° W.....	2"	.81		.89
	5"	.90		.74
	8"	.97		.80
90°.....	2"	1.08		1.08
	5"	1.40		1.17
	8"	1.14		1.30
60° E.....	2"	1.36		1.07
	5"	1.11		1.31
	8"	1.18		1.38
30° E.....	2"	1.95		1.73
	5"	1.39		2.21
	8"	1.14		1.88

\*The letters E. M. and W. M. denote the maximum declinations on the east and west sides of the magnetic line. The ratio in the last column gives the relative values of the maxima, and is obtained by dividing the number of degrees of the east maximum by the number of degrees of the west maximum.

TABLE VI.  
For Strike N. 30° W.

Dip	Depth	Ratio No. 1	Ratio No. 2
		Dist. of E. M. from 0	E. M.
		Dist. of W. M. from 0	W. M.
30° S. W.-----	2"	.64	1.33
	5"	.72	.85
	8"	.92	.86
60° S. W.-----	2"	.95	1.78
	5"	.98	1.37
	8"	1.07	1.17
90°-----	2"	1.14	1.98
	5"	1.20	1.84
	8"	1.50	1.59
60° N. E.-----	2"	1.24	2.09
	5"	1.13	2.03
	8"	1.30	2.26
30° N. E.-----	2"	1.55	1.87
	5"	1.42	2.45
	8"	1.50	2.80

TABLE VII.  
For Strike N. 60° W.

Dip	Depth	Ratio No. 1	Ratio No. 2
		Dist. of E. M. from 0	E. M.
		Dist. of W. M. from 0	W. M.
30° S. W.-----	2"	.50	0.87
	5"	.62	0.59
	8"	.73	0.96
60° S. W.-----	2"	.75	2.00
	5"	.88	1.37
	8"	1.15	1.54
90°-----	2"	.89	4.34
	5"	1.20	2.17
	8"	1.45	2.08
60° N. E.-----	2"	1.00	4.67
	5"	1.13	3.33
	8"	1.93	3.75
30° N. E.-----	2"	1.31	4.75
	5"	1.36	3.31
	8"	1.64	3.88

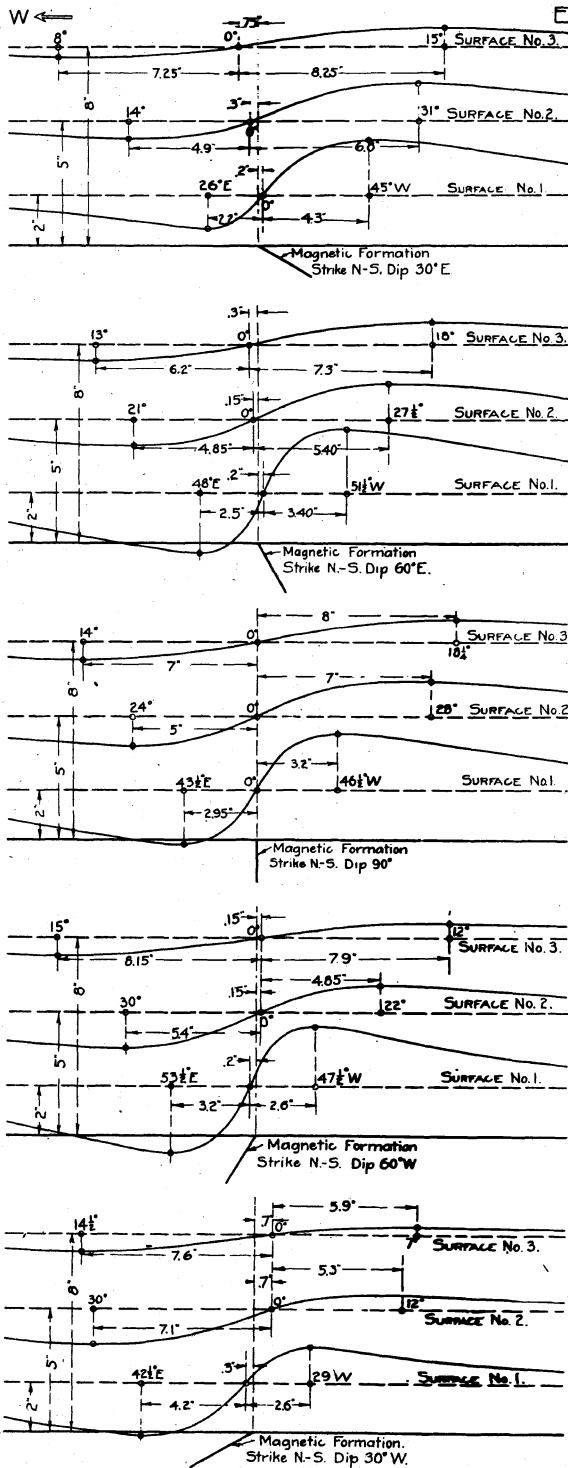

Fig. 24. Dial compass curves for N-S strike with various dips and depths of burial.

MINERAL LAND CLASSIFICATION

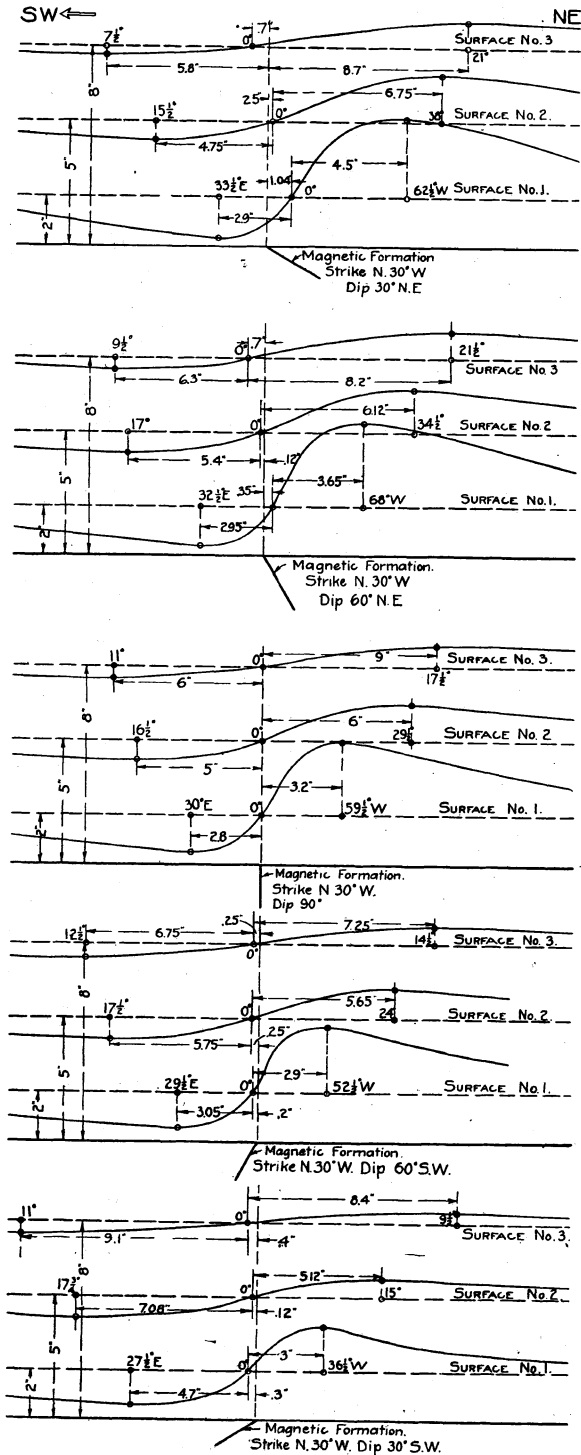

Fig. 25. Dial compass curves for strike N. 30° W. with various dips and depths of burial.

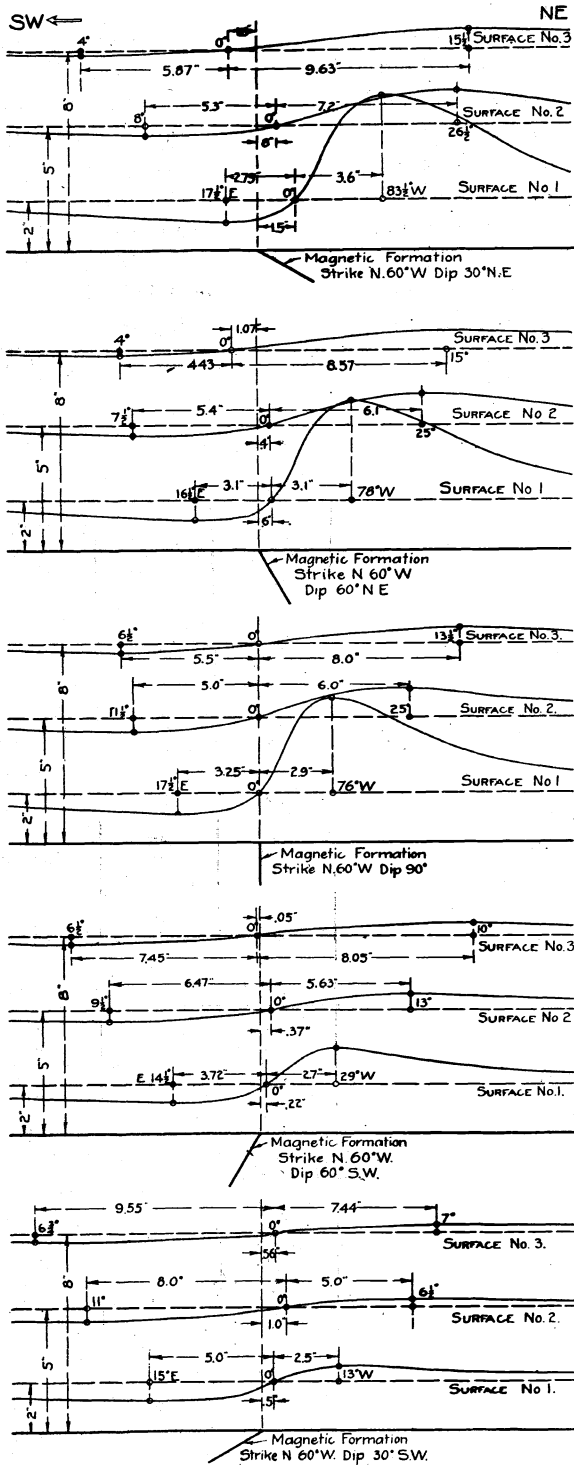

Fig. 26. Dial compass curves for strike N. 60° W. with various dips and depths of burial.

In order to check these experiments with a larger compass, and also for the purpose of getting the corresponding dip needle readings, another series of readings was made later, on an apparatus made by W. J. Mead for class demonstration. This apparatus was fitted with a holder for the dip needle, and the readings of both dip needle and dial compass were taken with the centers of the needles at exactly the same distance (6.4 inches) above the edge of the sheet of iron. Only one "depth" was taken for each position, instead of three as in the other experiment. Table VIII gives the results of this experiment as shown graphically in figure 27. It also shows the relation of the shape and position of the dip needle curve to the dial compass curve.

TABLE VIII

Dip	Dial Compass		Dip Needle			
	Ratio No. 1 Dist. of N. or E. M.	Ratio No. 2 N. or E. M.	Maximum Reading	Direction of Maximum from Dial Zero	Location of steepest slope of curves from Dial Zero	Location of negative read- ings from Dial Zero
	Dist. of S. or W. M.	S. or W. M.				
<b>STRIKE NORTH-SOUTH</b>						
30° W.....	.66	.62	42½	W	W	4.8'' W
60° W.....	.91	.82	46½	O	E	6.9'' W
90°.....	1.09	1.00	45½	O	W	7.4'' E & 7.2'' W
60° E.....	1.08	1.13	36	O	W	5.0'' E
30° E.....	1.16	1.41	33½	E	W	5.3'' E
<b>STRIKE N. 30 W.</b>						
30° SW.....	0.61	0.70	32	NE	NE	4.8'' W
60° SW.....	0.81	0.92	32	NE	None	7.4'' E & 5.2'' W
90°.....	1.01	1.29	35½	NE	None	NE
60° NE.....	1.22	2.09	37½	NE	NE	4.4'' E
30° NE.....	1.51	2.50	36	NE	NE	4.2'' E
<b>STRIKE N. 60 W.</b>						
30° SW.....	0.50	0.33	38½	SW	SW	5.1'' SW
60° SW.....	0.71	1.29	46½	NE	SW	6.5'' SW
90°.....	0.86	1.72	50		SW	None
60° NE.....	0.74	1.50	53½	NE	NE	4.9'' NE
30° NE.....	1.09	2.29	58½	NE	NE	3.5'' NE
<b>STRIKE E-W.</b>						
30° S.....	1	1	31		S	5.3'' S
60° S.....	1	1	40½		N	5.9'' S
90°.....	1	1	44½		N	7.2'' S
60° N.....	1	1	47		S	4.7'' N
30° N.....	1.37	2.75	51½		S	3.4'' N

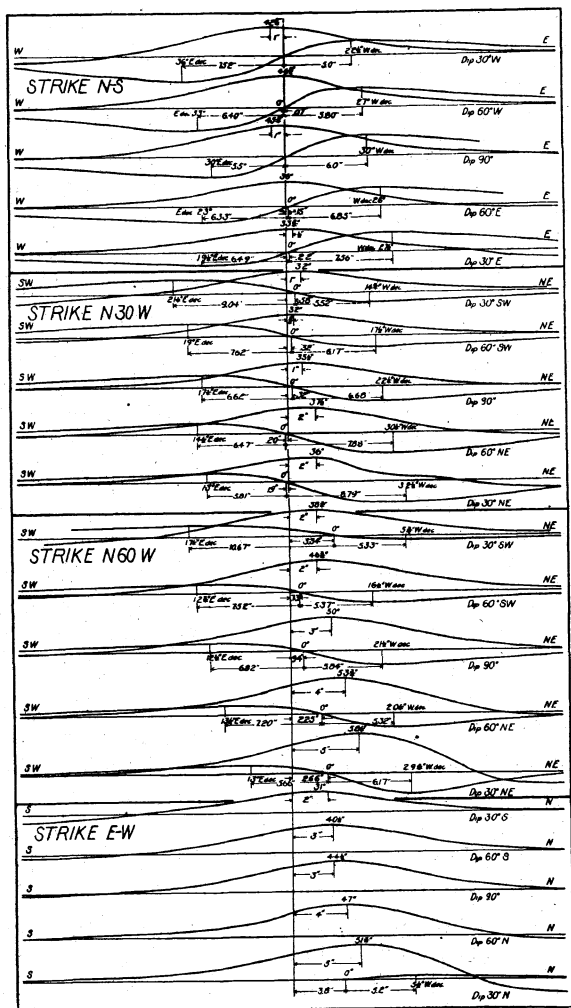

Fig. 27. Curves showing dial compass and dip needle readings for various positions of the iron sheet representing a magnetic formation.

From the plates and tables showing the results of these experiments the following generalizations appear for the particular apparatus used:

*Strike N-S.*—The dip of the beds is always toward the larger and more distant maximum. It is steep when maxima are nearly equal and at nearly equal distances from the zero point on the curve. It is gentle when differences between maxima is large and when the distances of the maxima from the zero point are markedly unequal.

When ratio No. 1 is less than .80 and ratio No. 2 is less than .70 the dip is about 30° W. Similar interesting generalizations appear for other dips of the formation.

Smyth states that the dip is "toward the nearer and (for north-south-striking rocks) the numerically smaller maximum." An inspection of the curves in figures 24 and 27 will show that in every case in the experiments made with a N-S strike it is the larger and more distant maximum that lies on the dip side. While the curve for the 90° dip indicates an unexpected lack of symmetry in the magnetic field, it does not seem that this is sufficient to cause the discrepancy between Smyth's mathematically derived conclusions and the experiments, for if it were, the curves for the dips to one side should agree with Smyth's statement, and curves for dips to the other side should be in marked disagreement. The curves show without exception, however, and in most cases quite strongly the correctness of the generalization that the dip is toward the greater and more distant maximum.

The dip needle curves of figure 27 and table VIII give comparatively little information. The most typical point is that negative readings are found only on the side toward which the formation dips, at greater distances for steeper dips; and are found on both sides of the 90° dip. Another point is that the maximum reading is found on the dip side of the zero dial reading when the dip is 30°. The determination of the direction of dip of a formation by magnetic observations is an uncertain thing, and every other bit of evidence bearing on the question should be secured. In spite of its uncertainty, however, it is sometimes the only evidence to be had in many cases and so is worthy of careful study.

*Strike N.30°W.*—For this strike the dial compass curves indicate that the dip is toward the more distant maximum, this rule failing to hold only for deeper buried beds dipping steeply S. W.

1. When ratio No. 1 is less than .90 and ratio No. 2 is less than 1.30 the dip is gentle and southward.



2. When ratio No. 1 is between .80 and 1.07 and ratio No. 2 is between .90 and 1.80 the dip is steeply southward.

3. When ratio No. 1 is between 1.00 and 1.40 and ratio No. 2 is between 1.30 and 2.25 the dip may be vertical or steeply to the northeast. The dip needle curves for these dips show very slight negative readings to the northeast for 90° dip and marked negative readings for the 60° N.E. dip.

4. When ratio No. 1 is greater than 1.40 and ratio No. 2 is 1.85 or greater the dip is gentle to the northeast.

5. Negative dip needle readings were almost invariably found on the dip side of the formation.

*Strike N.60°W.*—For this strike the dial compass curves indicate that the dip is usually toward the more distant maximum. This rule holds most strongly where the dips are gentle.

1. When the dip is gentle and toward the southwest ratio No. 1 is between .50 and .75 and ratio No. 2 is between .33 and 1.00. The dip needle curve shows its steep part on the dip side.

2. When the dip is steeply southwest ratio No. 1 is between .75 and 1.15, and ratio No. 2 is between 1.29 and 2.00. The dip needle curve has the steep part on the dip side.

3. When the dip is 90° ratio No. 1 is between .86 and 1.45, and ratio No. 2 is between 1.70 and 2.17, except when the depth is slight, when it may exceed 4.00. The steep part of the dip needle curve is on the dip side.

4. When the dip is steeply northeast ratio No. 1 may be between .74 and 1.93, and ratio No. 2 varies from 1.50 to 4.00 and even greater for slight depth. The steep part of the deep needle curve is on the dip side.

5. When the strike is gentle and toward the northeast there is little to distinguish the readings from those for steep northeast dip. Ratio No. 1 tends to be a little higher but not enough to be definite. The dip needle curves show negative readings only on the dip side, and the steep part of the curve is also on the dip side.

*Strike E-W.*—The dial compass gives no indication of the dip of the rock for this strike. Table VIII shows values other than 1 for ratios No. 1 and No. 2 when the dip is gently to the north. This indicates that the iron sheet used was not truly east-west or that one part of it was different from the rest in magnetic properties. The dip needle curves show negative readings on the dip side, and on the south side for a dip of 90°.

*General Conclusions.*—The character of a magnetic rock can usually be told by the magnetic readings. Sedimentary rocks such as iron formation usually give more regular and more continuous belts of attraction than igneous rocks.

The *strike* of magnetic rocks is determined by connecting points of maximum dip needle readings, or zero points on the dial compass curves for successive traverses across the formation. The line drawn to connect these points is known as a "magnetic line."

The *dip* of magnetic rocks may oftentimes be determined from the magnetic readings. The experiments conducted and tests made in the field agree, and show in general that the dip is toward the greater and more distant maximum for all strikes when the dip is less than  $60^\circ$ . This conclusion disagrees with Smyth's paper, and it is regretted that time does not permit a careful study to determine the reason for this disagreement. It may be due to Smyth's incorrect assumption (page 314, loc. cit.) that the magnetic force varies inversely as the square of the distance, or it may be due to the fact that the iron sheets used in the experiments were small in proportion to the distance between their poles and the compasses, when compared to a bed of magnetic rock and the distance of its poles from the compasses. At this point it is important to call attention again to the fact that the conclusions from these experiments apply only to the conditions of the experiment and need careful comparison with similar experiments made under known conditions in the field.

Negative dip needle readings are more likely to be found on the side toward which the rock dips according to the experiments, but too much dependence must not be placed upon this.

The *thickness* of a magnetic formation is always less than the distance between the maximum points on the dial compass curve.

The *width* of a magnetic curve—the distance across the strike through which abnormal attractions are found—depends upon the thickness and the depth of burial of the magnetic formation. A thin formation with a thin drift cover will give a narrow magnetic belt. With a thick cover the belt will be weaker and wider.

The *strength* of the local attractions depends upon the amount of magnetite in the formation and the depth of burial. Much magnetite means strong attractions, and little magnetite means weak attractions. A thin drift-cover means relatively stronger attractions than a thick cover.

*Not all iron formations are magnetic*, but most of them are. Magnetic lines of good characteristics are known to occur in the Lake

Superior iron regions chiefly in areas of Huronian sediments or in greenstone beds associated with them. Hence, all such magnetic lines in this area are believed to indicate areas of Huronian rocks in which iron formations are likely to be found.

### SECTION III.

#### DETERMINATION OF THE DIRECTION AND INTENSITY OF THE MAGNETIC FIELD OVER MAGNETIC FORMATIONS.

The direction assumed by the needle of the dial compass is the direction of the horizontal component of the magnetic field at that point of observation, but it gives no indication of what may be the actual direction of the magnetic pull. The position of the dip needle is due to the action of two pairs of forces acting to rotate it in opposite directions, as described on page 100, and consequently it also fails to give the actual angle of the earth's magnetic field. Neither instrument shows the actual strength—the intensity—of the magnetic attraction. As no observations on the actual direction and intensity of the earth's field in the neighborhood of magnetic formations were known it was decided to make a series in Florence County. Observations were first made at the southeast corner of section 20, T. 40, R. 18 E. as this was at a distance from known local attraction and it was believed would give the normal for the district. Other determinations were then made as given in table X, page 134. The purpose in selecting these places was to secure data showing the effect of a magnetic formation on the actual direction and intensity of the earth's magnetic field. Wherever possible observations with the ordinary dip needle and dial compass were made in the same places for comparison.

The determinations made were (1) the intensity of the horizontal component, and (2) the inclination or dip of the field. From these two the total intensity was computed. By taking many observations of each factor at each station a very satisfactory degree of accuracy was attained.

Professor E. M. Terry of the Physics Department of the State University kindly consented to assist the writer in this, and the following discussion of the work is to be credited to him, excepting for locations and descriptions, and other minor data.

*Instruments Used and Principles Involved.*

*I. The Magnetometer.*—The determination of H, the horizontal component of the earth's magnetic field was made by means of the magnetometer, i. e., a small magnet suspended by a silk fibre and free to oscillate through a small angle about its position of equilibrium. The period of such a magnet is given by the expression:

$$(1) \quad t = 2\pi \sqrt{\frac{I}{MH}}$$

Where  $t$  = time of one complete vibration.

$I$  = moment of inertia of magnet about the line of support.

$M$  = magnetic moment of magnet.

$H$  = intensity of the field in which it is vibrating.

If now,  $t_1$  and  $t_2$  are the periods in fields of intensities  $H_1$  and  $H_2$  respectively, we have:

$$(2) \quad t_1 = 2\pi \sqrt{\frac{I}{MH_1}}, \text{ and } t_2 = 2\pi \sqrt{\frac{I}{MH_2}}$$

Dividing, we have:

$$(3) \quad \frac{H_1}{H_2} = \frac{t_2^2}{t_1^2}, \text{ or } H_1 = \frac{t_2^2}{t_1^2} H_2$$

If  $t_2$  is determined for a known field  $H_2$ ,  $H_1$  may be computed by simply observing  $t_1$ . The measurement of  $H_2$ , the standard field, was made by means of the so-called "Absolute Magnetometer,"

and involves two determinations: (a)  $MH$ , and (b)  $\frac{M}{H}$ .

(a) *The Determination of MH.*—As seen from equation (1) this is readily obtained by observing the period of the magnetometer when vibrating in the standard field, and determining  $I$  from the mass and dimensions of its magnet. Thus:

$$(4) \quad MH = \frac{4\pi^2 I}{t^2}$$

$$(5) \quad \text{Where } I = \left( \frac{l^2}{12} + \frac{r^2}{4} \right) m$$

Where  $l$  = length of magnet  
 $r$  = radius of magnet  
 $m$  = mass of magnet.

(b) *The Determination of  $\frac{M}{H}$ .*—This is accomplished by observing the deflection of another much smaller magnet freely suspended in the standard field when acted upon by the magnetometer—magnet placed with its axis along the line of the perpendicular bisector of the small magnet; i. e., normal to the magnetic meridian, as shown in figure 28.

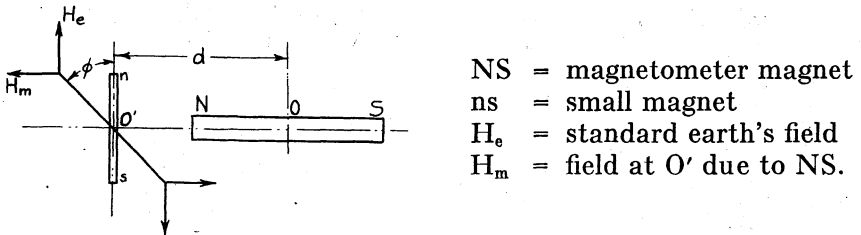

Fig. 28.

It is thus seen that while the earth's field tends to set  $ns$  normal to  $OO'$ , that of the magnetometer magnet tends to set it parallel to  $OO'$ . The equilibrium position, which is determined by the equality of the couples due to those two fields, is defined by the equation

$$(6) \quad M'H_e \sin \phi = M'H_m \cos \phi$$

Where  $M'$  = magnetic moment of  $ns$ .

$$(7) \quad \text{Whence } \frac{H_m}{H_e} = \tan \phi$$

$H_m$  is computed as follows, where  $m$  is the pole strength of  $NS$ .

$$\text{The field at } O' \text{ due to } N = \frac{m}{\left(d - \frac{l}{2}\right)^2}$$

$$\text{The field at } O' \text{ due to } S = \frac{-m}{\left(d + \frac{l}{2}\right)^2}$$

The total field at  $O' = H_m$

$$\begin{aligned}
 &= m \left\{ \frac{1}{\left(d - \frac{1}{2}\right)^2} - \frac{1}{\left(d + \frac{1}{2}\right)^2} \right\} \\
 &= \frac{m}{d^2} \left\{ \frac{1}{\left(1 - \frac{1}{2d}\right)^2} - \frac{1}{\left(1 + \frac{1}{2d}\right)^2} \right\} \\
 &= \frac{m}{d^2} \left\{ 1 + \frac{1}{d} + \frac{3}{4} \frac{1^2}{d^2} + \dots - \left( 1 - \frac{1}{d} + \frac{3}{4} \frac{1^2}{d^2} + \dots \right) \right\} \\
 &= \frac{2ml}{d^3} \\
 &= \frac{2M}{d^3}
 \end{aligned}$$

Substituting in (7)

$$\begin{aligned}
 \frac{2M}{d^3 H_e} &= \tan \phi \\
 \text{or } \frac{M}{H_e} &= \frac{d^3 \tan \phi}{2}
 \end{aligned}$$

$$\text{Whence } H_e^2 = \frac{M H_e}{\frac{M}{H_e}} = \frac{4\pi^2 I}{t^2} \frac{2}{d^3 \tan \phi}$$

$$\text{or } H_e = \sqrt{\frac{8\pi^2 I}{t^2 d^3 \tan \phi}}$$

II. *The Dip Circle*.—The essential parts of this instrument are a slender magnetized needle about eight inches long, with pointed extremities, mounted on agate knife edges at the center of a graduated vertical circle which is placed in the magnetic meridian, the axis of rotation of the needle being normal to the plane of the circle. The circle is mounted so as to admit of rotation about a vertical axis, its position being indicated by a pointer and horizontal graduated circle. The supporting base has three legs provided with level-

ing screws, and a level is placed upon the frame carrying the vertical circle. If the instrument is mechanically perfect, when the plane of the vertical circle includes the magnetic meridian, the needle will indicate the direction of the resultant earth's field.

The principal sources of error in dip determinations arise from the following instrumental imperfections:

(a) The axis of motion of the needle may not pass through the center of the vertical circle.

(b) The center of mass of the needle may not coincide with its axis of motion as regards the length of the needle.

(c) The center of mass of the needle may not coincide with its axis of motion as regards the breadth of the needle.

(d) The magnetic axis of the needle may not coincide with its axis of figure.

(e) The vertical circle may not be properly set with reference to its axis of rotation; i. e., the line passing through the upper and lower 90° reading may not be vertical.

These errors may be eliminated in the following manner:

(a) By reading both ends of the needle.

(b) By reversing the polarity of the needle, thus causing the opposite end to dip.

(c and d) By turning the needle over in its bearings.

(e) By turning the circle through 180°, thus bringing the ends of the needle into different quadrants.

### *Standardization of Instruments.*

I. *The Magnetometer.*—To standardize the magnetometer a point on the University Drive in Madison was selected at a long distance from railroad tracks, steel structures, etc., where the earth's field is very uniform. The period of vibration of the magnetometer, whose angular amplitude never exceeded 5°, was determined by a stop watch reading to fifth's of a second. This watch had previously been compared with the standard clock of the Washburn Observatory and found to have a rate of less than 1 part in 2000 which was deemed sufficiently accurate for the work in hand. The following are the times observed for twenty complete vibrations:

88.2 sec.

88.0

87.8

88.2 Period of one vibration  $= t = \frac{88.12}{20} = 4.406$  sec.

88.4

---

 Mean 88.12''

The constants of the magnetometer magnet are as follows:

Diameter	Length	Mass
(Mean of 5 determinations)—.3979cm	5. cm	4.734 grams.

$$\begin{aligned}
 \text{Moment of Inertia} &= \left( \frac{l^2}{12} + \frac{r^2}{4} \right) m \\
 &= \left( \frac{5^2}{12} + \frac{.1987^2}{4} \right) 4.734 \\
 &= 9.910 \text{ gram cm}^2
 \end{aligned}$$

Substituting in equation (4), we have

$$MH = \frac{4\pi^2 I}{t^2} = \frac{4\pi^2 9.91}{4.406^2} = 20.18$$

For the determination of  $\frac{M}{H}$ , the absolute magnetometer belonging to the Electrical Laboratory of the Physics Department was used, the angle  $\phi$  (see figure 28) being measured by a telescope and scale, the distance between the scale and magnetometer mirror being 175.5 cm. Three determinations were made, using different values of  $d$ , placing  $NS$  on opposite sides of  $ns$ , and reversing between each setting. The results of these determinations, the value of  $\frac{M}{H}$  and the value of  $H$  are given in table IX, in which  $D$  is the observed deflection of the beam of light on the scale.



TABLE IX.

Calculation of  $\frac{M}{H} = \frac{d^3}{2} \tan \phi$ .

	d	D	$\tan 2 \phi^*$	$2\phi$	$\phi$	$\tan \phi$	$d^3$	$\frac{M}{H}$
I. ....	38.1	7.76	.0448	2° 34'	1° 17'	.0224	55300*	619.
II. ....	33.1	11.93	.0687	3° 54.5'	1° 57.3'	.0341	36270	617.5
III. ....	28.1	19.55	.1126	6° 21'	3° 10.5'	.0557	22190	617.
							Mean.....	618.

$$H^2 = \frac{MH}{M} = \frac{20.18}{618} = .03265$$

$$H = .1808 \text{ gauss}^{**}$$

II. *The Dip Circle.*—The only standardization for the dip circle, aside from making the needle as nearly balanced mechanically as possible and polishing the bearings, is to secure parallelism between the level and the supporting frame of the vertical circle. This was accomplished in the usual manner of adjusting a level bubble.

The determination of the dip in the standard field was as follows:

	A Dipping			B Dipping		
	U	L	Mean	U	L	Mean
EP.....	77	76.6	76.8	74.4	74.3	74.35
WF.....	72.8	73.	72.9	77.9	77.8	77.85
WB.....	80.	80.	80.	74.7	74.9	74.8
EB.....	74.6	74.4	74.5	77.1	76.6	76.85
	Mean....		76.05	Mean....		75.96

$$\text{Dip} = 76.005^\circ$$

The above letters have the following meanings:

A, B = labels on ends of needle.

U, L = reading of upper and lower ends of needle on vertical circle.

\*The reflected beam is turned through twice the angle of rotation of the mirror.

\*\*The gauss is the unit of field strength. It is defined as a field which acts on a unit pole with unit force (1 dyne).

$E_F$  = Vertical circle turned to read from the east and lettered side of needle facing graduated side of circle.

$W_F$  = vertical circle turned to read from the west and lettered side of needle facing graduated side of circle.

$W_B$  = vertical circle turned to read from the west and back of needle facing graduated side of circle.

$E_B$  = vertical circle turned to read from the east and back of needle facing graduated side of circle.

The dip circle readings were always taken in the above order, and this nomenclature will be followed throughout.

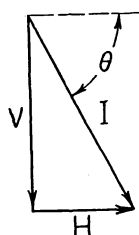

Fig. 29.

Calling  $H$  = Horizontal intensity of Earth's Field

$V$  = Vertical Intensity of Earth's Field

$I$  = Total Intensity of Earth's Field

$\theta$  = Angle of Dip

We have  $V = H \tan \theta$

$$I = \frac{H}{\cos \theta}$$

The constants of the standard field are then as follows:

$$H = .1808$$

$$V = .1808 \times 4.012 = .7228$$

$$I = \frac{.1808}{.2419} = .7475$$

$$\theta = 76.006^\circ$$

#### METHOD OF TAKING OBSERVATIONS.

The routine followed in making a determination was as follows: a Johnson plane table, the large table of which was replaced by a smaller one 12x12x2 inches, was set up at the desired position, made approximately horizontal by means of a small pocket level, and clamped. The table was then rotated until one of its edges was parallel to the magnetic meridian, as indicated by a sensitive compass. The dip circle was then placed upon it and set so that the pointer on the horizontal circle read zero, when the base was turned until the plane of the circle was parallel to the edge of the table. The circle was then carefully levelled by means of the levelling screws. The needle was then magnetized and the observations

taken as indicated on page 129, A dipping; after which it was removed and its magnetism reversed by stroking with a strong bar magnet, when the same readings were taken with B dipping. The dip circle was then replaced by the magnetometer, and the time of 20 complete vibrations measured several times by the stop watch.

## RESULTS.

In order to test the accuracy with which observations could be repeated, and to gain an idea of the undisturbed field in the locality of Florence, a few determinations were made about half a mile west of the village, at a considerable distance from railroad tracks and ore deposits. Station No. 1 was at the southwest corner of section 20, T. 40, R. 18 E. in the middle of the road. Stations No. 2, No. 3 and No. 4 were in the road, respectively 100, 200 and 300 feet west of Station No. 1. Determinations were then made in an area of general high attractions on the Commonwealth lands. The place chosen was about 40 paces west of the old field, near the west side of section 34, and the stations were north of the main road to the Buckeye mine. Station No. 1 was 20 paces north of the road, No. 2 was 100 feet north of No. 1, No. 3 was 200 feet north of No. 1.

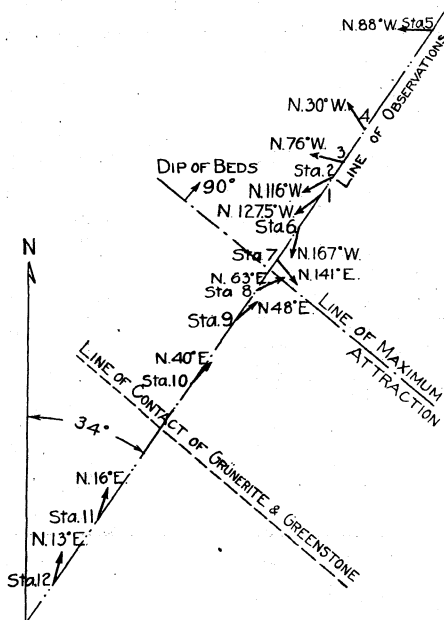

Fig. 30. Magnetic observation stations on Dunkles farm. Arrows give dial compass directions.

The day following the making of these determinations was rainy, so it was decided to take some observations underground in the Florence mine. The observations were made in abandoned workings as far as possible from tracks and electric wires. Station No. 1 was on the 5th level and No. 2 was on the 3rd level near the hanging wall in number 8 crosscut, 20 feet north of the east drift.

The main series of determinations was made across the magnetic line on Dunkle's farm. The location of the various stations and the declination of the horizontal needle at each station are shown in figure 30. The position of Station No. 1 on this line is about 50 feet north of the pit in grunerite schist, 85 paces west and 740 paces south of the  $\frac{1}{8}$  corner between the N. E. corner and the N $\frac{1}{4}$  stake of section 35, T. 40, R. 17 E. The line on which the observations were made was approximately at right angles to the strike of the magnetic bed. The drift cover over the magnetic rock was about five feet, as near as could be estimated. The greenstone southwest was outcropping. The results of these observations are all given in table X.

TABLE X.

SUMMARY OF RESULTS.

Location	Station No.	Period of Vibration	H	Dip	V	I	Dip Needle	Dial Compass
S. E. cor. of Sec. 20, T. 40, 18 E.....	1	4.85	.1493	75.89	.5945	.6128	0°	.....
	2	4.85	.1493	75.88	.5945	.6128	0°	.....
	3	4.857	.1488	75.90	.5924	.6108	0°	.....
	4	4.863	.1484	75.85	.5885	.6030	0°	.....
West line of Sec. 34 T. 40, 18E.....	1	4.79	.1530	76.22	.6235	.6410	7.5	.....
	2	4.807	.1518	76.00	.6094	.6280	7.5	.....
	3	4.805	.1520	76.27	.6255	.6437	8.	.....
Florence Mine.....	1	4.82	.1511	75.67	.5910	.6108	.....	.....
	2	4.76	.1550	75.96	.6185	.6400	.....	.....
Dunkle's Farm.....	1	5.375	.1215	81.67	.8432	.8508	49°	128° W
	2	6.155	.09285	82.89	.7445	.7500	47°	116° W
	3	7.67	.05970	84.73	.6480	.6520	49°	76° W
	4	7.62	.06046	84.59	.6385	.6405	52°	30° W
	5	4.485	.1745	76.15	.7078	.7292	18°	88° W
	6	5.315	.1242	83.22	1.002	1.052	63°	163° W
	7	4.480	.1748	82.96	1.327	1.337	66°	153° E
	8	3.150	.3538	71.46	1.0560	1.1130	41°	63° E
	9	3.026	.3835	65.67	.8480	.9312	22°	48° E
	10	3.184	.3466	67.59	.8400	.9090	7°	40° E
	11	4.145	.2042	71.25	.6020	.6360	0°	16° E
	12	4.273	.1922	72.43	.6073	.6373	-1°	13° E

The "dip needle" column gives the variation from normal of an ordinary dip needle balanced so its normal reading was +12°. The "dial compass" column gives the delination of the horizontal needle from its normal position 2 $\frac{3}{4}$ ° east of north.

The variations of the magnetic elements and the behavior of the counterpoised dip needle—the kind ordinarily used in the Lake Superior iron districts—in crossing a magnetic formation may be seen from figure 31, where the observations taken on Dunkle's farm have been platted. Perhaps the most striking feature of these curves is the tendency of the counterpoised dip needle to follow the

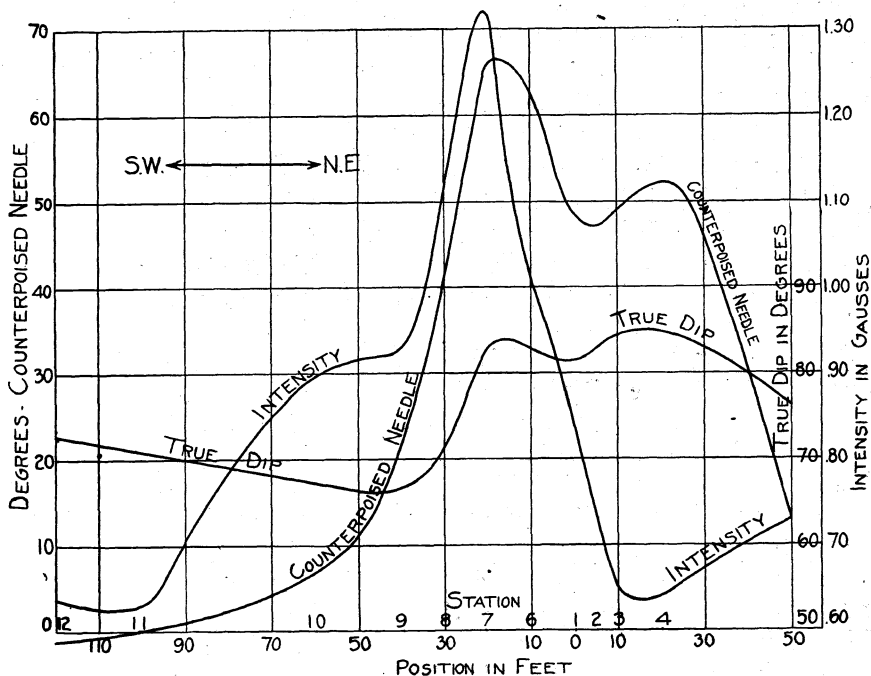

Fig. 31. Curves showing magnetic observations on Dunkle's farm west of Florence.

variations in both the intensity and the dip of the earth's field. That it should behave in this manner may be seen from the following considerations: Let  $I$ , the long arrow in figure 32, represent the direction and magnitude of the earth's field, and let  $AB$  be the position of the needle which is mounted at  $O$ , with its center of mass at  $m$ . The condition for equilibrium is given by  $k \cos \theta = I M \cos \phi$ .

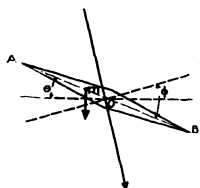

Fig. 32.

- $M$  = magnetic moment of needle.
- $\theta$  = indicated dip.
- $\phi$  = angle between axis of needle and the normal to  $I$ .
- $k$  = a constant depending upon mass of needle, distance of center of mass from axis of rotation, etc.

The right hand member of this equation represents the couple tending to produce a rotation in the clockwise direction, i. e., to increase the reading of the instrument, while the left hand member represents the couple tending to decrease it. It is thus evident that a change in either the magnitude or the direction of  $I$  will affect the indication of the instrument, but that the change of reading is in no wise proportional to the change in  $I$ , since the restoring couple is proportional to  $\cos\theta$  instead of  $\theta$ . Thus, if  $\theta$  is large,  $\cos\theta$  is small, and changes rapidly with  $\theta$ . In this position, a small change in the direction of  $I$  will produce a large change in  $\theta$ , but in this position the instrument is relatively insensitive to changes in the magnitude of  $I$ , since the angle between  $I$  and the axis of the needle is small. This fact is illustrated by the observations at stations 4 to 7 on the plat, where it is seen that the changes in true dip are magnified in the curve for the counterpoised needle, while it has not as sharp a maximum as the intensity curve, showing the decrease in sensibility to this factor.

On the other hand, when  $\theta$  is small, the restoring couple is large, thus reducing the sensitivity to changes in both the magnitude and direction of  $I$ ; but on account of the decrease in  $\phi$  in this position, the sensitivity to changes in magnitude of  $I$  is relatively increased. Thus, at stations 9 to 12, although the true dip is increasing, the rapid increase in intensity reduces the readings of the counterpoised needle to very small and even negative values. Because of the dependence of the counterpoised dip needle upon these two factors, and of the varying effectiveness of each with position, the impossibility of separating them is apparent. Hence, the instrument cannot be used for quantitative determinations; but as a qualitative instrument for locating magnetic disturbances it is very sensitive, and has a large field of usefulness.

## CHAPTER V

## LAND CLASSIFICATION

*Land Classification Necessarily a Public Function.*—The people of the state of Wisconsin are interested in and benefited by the development of all parts of the state to the fullest possible extent. The building up of the manufacturing industries of any section brings a new element of prosperity not only to the people of that particular locality but to many people in other localities and in apparently unrelated lines of endeavor. The agricultural development of northern Wisconsin is not only of benefit to the farmers who profit by their labors and the rise in land values, but it also makes more business for the cities both of the immediate region and at long distances from it. The prosperity of these cities makes better markets and greater prosperity for the farms surrounding them. It is thus easy to see how the farmer clearing land in northern Wisconsin is of direct benefit to a farmer in Milwaukee, Dane or Rock county. The benefit may be small in an individual case but is large in the aggregate. The full development of any natural resource likewise reflects its benefits over a wide territory. The cases are rare where an individual can prosper greatly without directly or indirectly increasing the prosperity of many of his associates and the community in which he lives.

Notwithstanding the evidently good public policy of promoting the development of an iron mining industry in northern Wisconsin the question is sometimes asked "why should the state do this—why should it not be left to the individual initiative of those interested." The direct answer is that the people collectively, through the state government, can at slight expense do what the individual land owners would find prohibitively expensive. On this same principle the state maintains an agricultural department to carry on beneficial investigations that individual farmers could not afford, a factory inspection system to do for the good of the individual working man what he could not afford to do for himself, and many similar activities. As a matter of fact the basic principle of all govern-

mental activity is for the people as a group to do certain things that they can do more cheaply and more effectively than as individuals.

The indirect answer to the question is that it is beyond the bounds of practical possibility to get the land holders to unite to carry on such work. There is an area of about 360 square miles in northern Wisconsin, not included in this report, where the indications would warrant the private owners in paying for such a survey. In 1911 the ownership was concentrated in few hands, and to these owners the proposition was made that this Survey would take active charge of the work and furnish expert supervision without charge provided it was given the right to publish the results. Many of the owners were willing to pay their share but it was found impossible to get them all together.

In a hearing before the Finance Committee of the House of Representatives at Washington, Representative Sherley made the statement that "so far as the development of the mineral resources of the country is concerned, it is just as important to know the resources of privately owned lands as of government owned lands."\* The state of Wisconsin is not particularly interested in discovering the fact that on a particular 40-acre tract of land belonging to George Smith there may be iron ore, but it is very much interested in the fact that in that region there is the possibility of developing a mining industry that will add millions of dollars to the wealth of its citizens. It was for this purpose that the surveys made for this report were directed to be made by the legislature and the necessary money appropriated.

*Purposes of Land Classification.*—"Utilization of lands for their greatest value necessitates the determination of that value (or those values, W. O. H.), which is, briefly, land classification; and, to be adequate, land classification must be based on first hand acquaintance with the land under consideration."\*\* In northern Wisconsin the greatest value of the lands is usually the agricultural value. Other values sometimes so greatly exceed this as to become the paramount consideration. These other values consist chiefly of timber, water power possibilities, and mineral rights. The timber values very often are exclusive of agricultural values; that is, certain lands are of so little agricultural value that their value for forestry purposes exceeds any probable value for agricultural purposes. Such

\* Thirty-fifth Annual Report of the Director of the U. S. Geological Survey, p. 10.

\*\* The classification of the Public Lands. George Otis Smith and others. Bull. 537, U. S. G. S., p. 7.



values are determinable only by a careful classification on the basis of soil conditions—a soil survey—such as this Survey is now conducting over the whole state.

The water power values are exclusive of other values. Use of land for water storage destroys the value for agricultural and mineral development. Such values can be obtained only through a classification of the lands by a survey of the power possibilities, such as this Survey carried on for a number of years, and is now being carried on by the state Railroad Rate Commission in cooperation with the United States Geological Survey.

The mineral values are not exclusive of the agricultural values but are additional to them. Land may be of value for both purposes and used for both purposes. Indications of the presence of iron ore, upon which mineral values depend, can be determined by a geologic and magnetic survey such as forms the basis of this report, and a survey of this kind is necessary for the intelligent classification of mineral lands.

Recognition of the existence of possible mineral value in the lands of northern Wisconsin has been a matter of common business for many years. It is probable that most transfers of large land holdings made in the last ten or fifteen years have conveyed title to the agricultural and timber values only. Many pieces of land sold to settlers have been transferred subject to the reservation of the mineral rights. Concerning the actual presence of mineral values nothing has been known in detail, but there has been sufficient general knowledge to warrant following this procedure as a practical business policy.

A classification of the lands of northern Wisconsin on the basis of mineral value should therefore have for its purpose two things; first an expression of all the positive determinations that can be made of the presence or absence of such values; and second, grading according to the evidence available all lands for which positive determinations are impossible. If the geology of certain lands is such that there is no possibility of iron ore being found this should be ascertained and made known. If certain other lands are known to be underlain by iron-bearing formations this positive determination should be made and published.

It is always the case in the examination of lands for such a classification that these positive determinations can be made only in certain favorable areas where the evidence is unusually good. Much of the area examined will be so completely covered by soil

or other mantle rock that the evidence obtainable will be what a lawyer might call "circumstantial" and will only indicate possibilities or probabilities without furnishing the definite proof necessary for a positive determination.

An adequate scheme of classification must therefore contain not only provisions for positively definable classes but must provide classes graded according to the strength or weakness of the indications found. These classes must be understood to be subject to revision as rapidly as the discovery of new evidence permits positive determination. This new evidence for the area considered in this report must come largely from reports of exploration work and from information obtained from wells. If persons drilling wells to rock will send samples of the rock found to this Survey it will be of great assistance in more definitely classifying the lands, and the courtesy will be appreciated highly.

*Principles of Iron Land Classification.*—The iron-bearing formations of the Lake Superior region occur only in pre-Cambrian rocks. The iron producing formations are localized in belts of limited extent. Their locations and extent are shown in a general way in figure 1, page ——. It will be noted, on reference to this figure, that these productive ranges lie in the great area of pre-Cambrian rocks stretching from Grand Rapids, Wis., northward beyond Lake Superior, covering most of northern Michigan and Minnesota and extending across northern Wisconsin. It will also be noted that there is a general trend of these ranges in a direction somewhat north of east. As this general trend of the pre-Cambrian formations is known to be continuous across northern Wisconsin the expectation is warranted that somewhere, concealed beneath the thick glacial drift, the iron-bearing formations are present in this state, as well as in those regions of Michigan and Minnesota where the rocks are better exposed. This fact of identity of geologic age and structure is the general principle on which to base the classification of northern Wisconsin as possibly iron-bearing.

The problem is then presented to limit these general possibilities to as closely prescribed areas as the information obtainable will permit. This is accomplished by two methods; first, a careful study of all rock exposures, and securing all the information that these may offer, and second, a careful magnetic survey to secure all the information that the magnetism of the rocks may give.

It must be borne in mind constantly that the point of view in this report in interpreting the information obtained in these ways for the

purpose of eliminating lands must be radically different from that of the successful explorer. The explorer is justified in condemning for his purposes, which are immediate, all lands that do not at present offer strong encouragement of a successful outcome to his work. The point of view of this report must be to consider that all lands offer some possibilities for the discovery of ore, unless they are definitely known to be underlain by rocks in which ores cannot occur. The explorer demands definite information, which in many cases is not available, and the geologist must recognize that, while this information is not now available, it may become so in the future.

With regard to the value of a magnetic survey for the purposes outlined the following statement will be of interest.

"All ores of iron are found to be magnetic when tested by sufficiently delicate means. Ordinarily magnetite is the only iron mineral which causes conspicuous disturbance of the magnetic needle. Practically all the Lake Superior iron-bearing formations contain at least minute quantities of magnetite, and hence all exert an influence on the magnetic needle, but in widely varying degree. The iron-bearing formation of the Vermilion district and other Keewatin areas is strongly magnetic. The same is true of the formation in the east end of the Mesabi district, the Gunflint district, the Cuyuna district, and the east and west ends of the Gogebic district, and of most of the Negaunee formation of the Marquette district. Less magnetic parts of the iron-bearing formations are those producing principally hematite and limonite, as the central and western parts of the Mesabi, the central part of the Gogebic, and parts of the Menominee and Crystal Falls districts. The iron-bearing member of the Iron River district of Michigan affects the magnetic needle only locally and slightly."

"Every known iron-bearing formation in the Lake Superior region, with the exception of that in part of the extreme west end of the Mesabi district, has been outlined partly as a result of magnetic surveys. In some of the districts, as, for instance, the Iron River district, the magnetic variation is slight, but careful observations will detect it. In addition several magnetic belts are known in which exploration has not yet shown the character of the iron-bearing formation."\*

The principles of classification of iron-bearing lands have been worked out as the result of many years of careful, detailed geologic and magnetic surveys of the productive iron ranges of the Lake

\* The Geology of the Lake Superior Region, C. R. Van Hise and C. K. Leith. Mon. LII. U. S. G. S., p. 486.

Superior region by the U. S. Geological Survey, the various state geological surveys and the large mining companies which have maintained staffs of geologists. They have been, and are, in constant successful application, both by public and private surveys, and there is no new principle involved in the work done for this report. The only difference from established usage is that heretofore the private surveys have usually been the ones that have gone into new or previously unproductive territory, and the official surveys have, in general, followed the first discoveries of ore.

*System of Classification Adopted.*—The classification adopted for the lands covered in this report has the purpose stated and is based on the principles outlined above.

The lands are divided into five classes. Two of these classes include the lands for which reasonably definite classification is possible. Those known to contain iron formation are the "Class A" lands. Those known to be underlain by rocks in which iron ore is not found are the "Class D" lands. The other three classes include those for the definite classification of which sufficient evidence is not available at present. These are classified according to the character and amount of evidence pointing toward the presence or absence of iron formation.

Classes A and B, and the most favorably situated of Class C, are recommended for more detailed examination. It is believed that a detailed examination will show that a fair percentage of this land is worthy of exploration by drilling.

In the township descriptions are paragraphs giving recommendations for or against the advisability of exploring in each township, and pointing out in detail the most favorable locations for exploration if any work is to be done.

The details of evidence to be looked for to determine the class in which particular parcels of land should be placed are as follows:

*Class A Lands.*—This class includes all land in which iron formation is known to be present. This may be shown by either one or more of the following lines of evidence.

1. Outcrops of iron formation. No attempt has been made to subdivide this class into lands containing rich or poor iron formation.
2. Crossed by magnetic lines traced from outcrops of iron formation found elsewhere.
3. Exploration records, either drill holes or test-pits, which show the presence of iron formation.

4. Contiguity or relation to known iron formation, such as the presence in an adjoining section of a belt of iron formation striking toward the land in question, with some other evidence that the same strike continues.

*Class B Lands.*—This class includes all lands which show strong but not positive evidence of the presence of iron formation. This may be shown by any one of the following lines of evidence. (Some of these lands are possibly better to explore than some in Class A).

1. Abundant angular pieces of iron formation with or without a magnetic line.
2. A moderate amount of angular iron formation drift with a magnetic line of good characteristics (see page 84).
3. Magnetic line of good characteristics in slates or other Huronian sediments. Since the iron formations are almost always associated with slates, the presence of a good magnetic line in rocks of this character is strong evidence of the presence of iron formation.
4. Geological relations showing a succession of formations which elsewhere contain an iron formation but for which no local evidence—such as drift or a magnetic line—can be found.

*Class C1 Lands.*—The Class C lands are those concerning which little information is available. They are divided into two classes on the basis of magnetic lines, and the geologist's best judgment as to whether or not they are underlain by Huronian formations in which an iron formation may occur. The Class C1 lands are those probably underlain by Huronian rocks and crossed by magnetic lines showing good characteristics. Some of these lands with the best magnetic indications may be better to explore than some in Class B.

*Class C2 Lands.*—These include lands which may possibly be underlain by Huronian rocks, have irregular magnetic lines or none at all, and no other indications of the presence of iron formation. For the classification of these lands there is very little or no information available. They may be underlain by igneous rocks, and many sections in this class undoubtedly are, but there are no outcrops or other data showing this. Because of the lack of evidence they are not recommended for exploration, but this fact must not be interpreted as meaning that there is no chance for the finding of iron ore

in this class of lands. The prudent man will not spend much money in exploring them, neither will he condemn them absolutely.

*Class D Lands*—This class includes all lands known to be underlain by rocks in which iron ore does not occur in the Lake Superior region. Thus lands underlain by granites, gneisses, schists, Keweenawan traps and sediments, Huronian quartzite, rhyolites and syenites are as a rule put in this class. Greenstones may be closely associated with iron formation so the lands underlain by them cannot be safely put in this class. Another exception must be made in the case of the Barron quartzite which is believed to be only a thin cover over the older rocks in much of the area where it is found. The land where this is true must usually be placed in one of the C classes.

It is obvious that the foregoing classification must be arbitrary in many cases. In fact it is unusual that there are instances where the evidence is so complete that there is no room for honest difference of opinion. The experience of the U. S. Geological Survey in classifying the lands of the public domain in the western states agrees with our own.

“In preparing the regulations for classification three principles are paramount: (1) The regulations must be based on demonstrated facts or on well-founded and generally accepted inferences; (2) they must be based on all stable, permanent factors involved; (3) they must be as definite yet withal as simple as possible. Ideally the regulations should be so simple that anyone at all acquainted with the subject could correctly apply them, and they should be so definite as to admit of little or no disagreement in interpretation. Neither of these ideal requirements can be realized.”\*

\* Classification of the Public Lands. Loc. cit., p. 66.

## CHAPTER VI.

## EXPLORATION FOR IRON ORE

*Definition.*—As the term is ordinarily used in the Lake Superior iron ranges exploration refers to the local intensive operations in the search for ore on a particular piece of property, and includes only drilling, test pitting and mine explorations. In the title of this chapter it is used in a broader sense to cover all the operations incidental to the discovery of iron ore. In this sense exploration includes (1) the general survey such as has been made of the area covered by this report; (2) the detailed magnetic and geologic survey such as should be made of small portions of the area in which drilling operations are contemplated, and (3) drilling, test pitting, and mine exploration.

This report and the maps accompanying it give the general facts of geology and magnetic attraction, and indicate certain areas worthy of close work to ascertain the structure in detail. Traverses were made a half mile apart, and consequently cannot show up the minor details of the structure on which the concentration of ore would depend.

*Elimination of Barren Areas.*—The general principle on which all intelligent exploration work must be conducted is the elimination of barren areas by cheap, rapid methods, so as to concentrate the great part of the expensive work—drilling and testpitting—on the most favorable areas. It is obvious that only a minute fraction of any large area can be underlain by ore. The task of intelligent exploration is to find this minute fraction with the least possible expense.

This report eliminates from further consideration a large portion of the lands covered. It also points out certain restricted areas as worthy of further examination. These areas are privately owned and of small extent so it is proper that further work in the nature of detailed examination and drilling should be carried on by the owners and not at public expense by this Survey. This

more detailed geologic and magnetic examination will still further cut down the area to be explored by test-pits or drilling. Drilling operations should then be carried on in the most favorably situated lands with the purpose, first, of finding the iron formation, and then of outlining the richer parts and eliminating unprofitable areas of the iron formation itself.

The following statements from an article by C. K. Leith\* present these facts with such excellence that they are given at length.

Some sort of a geological survey of an area, professional, amateur, or otherwise, is now usually regarded as an essential preliminary to exploration for iron ore. The function of the geological survey for exploration purposes is to eliminate the barren areas. The Lake Superior ores are in certain definite iron formations of sedimentary type which can be followed by ordinary stratigraphic methods, and few now wish to spend money in exploration in an area of granite or quartzite, or other non-iron-bearing rocks. In the past this was not as true as it is now, as shown by the expenditures that have been made in such areas. So much of the Lake Superior country is drift-covered that the tracing of iron formation requires magnetic surveys and careful study of structure and stratigraphy in order to extend and connect the iron belts properly through covered areas. There is practically no phase of physical geology which can not be employed to advantage in delimiting the limits of the field of most promise for exploration. \* \* \* \* It is not true that all magnetic portions of the iron formation are to be eliminated \* \* \* \* but nearly all of the extremely magnetic and silicated phases are to be eliminated. One of the commonest fallacies is that high magnetic attraction is a favorable indication of an ore body. Looked at from the standpoint of Lake Superior experience as a whole, a strong magnetic belt is an unfavorable indication for ore close at hand. In support of this statement I need only cite the slightly magnetic character of the great hematite bodies of the Mesabi and other Lake Superior ranges, as compared with the highly magnetic properties of the lean east Mesabi, east and west Gogebic, and other parts of the Lake Superior ranges. A strong magnetic belt may indicate the existence of the iron formation and gives a valuable starting point in working toward less metamorphosed phases of the formation where there is better promise of finding commercial grades of ore. \* \*

By processes of elimination requiring careful geological study at every step the explorer may come to a consideration of about 75 square miles of iron formation in the Lake Superior country.

Within the area thus localized the problem now is to find the parts concentrated to iron ore. Concentration is effected by water and the atmosphere, and accessibility of these substances to the iron formations determines the localization of the ores. There is the greatest variety of factors which determine the localization—whether the beds are flat or on edge, the existence of impervious basements or covers, faulting, jointing,

\*Leith, C. K. Use of Geology in Iron Ore Exploration. Economic Geology, Vol. VIII, No. 7, Oct.-Nov. 1912, pp. 662-669.



nature of the folding, porosity, area of exposure to the surface, and other factors. If you stop to think of the variety of ways that surface solutions can get at rocks effectively you may appreciate in some measure the complexity of the conditions under which the ores may be found. Other things being equal, the concentration is roughly proportionate to the area of exposure of the iron formation to the erosion surface, all the remaining factors being subsidiary and modifying. This is something more than the statement of an academic principle, for it has been worked out in terms of acres and tons of iron ore and iron formation for the different districts. \* \* \* \*

In the Mesabi district, after elimination of the non-productive east and west ends of the range, 8 per cent of the remaining area of the iron formation is known to be ore. In the Vermilion district, between Tower and Gunflint Lake, 2.3 per cent of the surface of the iron formation is ore. In the Michigan ranges, collectively, the present ore area is .6 of a square mile, or 1.5 per cent of the favorable iron formation after elimination of obviously barren phases. But making allowance for ore area mined out and probable further discoveries the true percentage is probably nearer 4 per cent. The lower percentages of ore areas in the steeply-tilted iron formation of Lake Superior, as compared with the flat-lying Mesabi, does not necessarily mean a smaller proportion of ore, for there are better chances of continuance with depth in the steep-dipping than in flat-lying beds, as I shall show later. \* \* \* \*

Careful geological study of any area being explored in detail still further limits the area of exploration. It will be found that one part of the forty acres the formation is richer than another part; that is more leached and porous than on another part, that there are various structural features which favor one part rather than another. Work started miscellaneous over the forty acres will gradually converge toward one spot. The rapidity and effectiveness of this convergence depends largely upon the extent to which the geology, the structural relations and origin of the ores are understood. \* \* \* \* There is almost no fact relating to the structure or metamorphism, conditions of sedimentation, chemistry of deposition of the ore, factors entering into secondary concentration—no matter how apparently unrelated to practical exploration—which does not contribute to a comprehension of the possibilities in a given situation, and facilitate the finding of the ore. \* \* \* \*

Of course there is much successful exploration which does not utilize these methods. If the exploration is followed far enough ore is found in about the average proportions already indicated. If lucky, the explorer may find it at once and not be at the necessity of using these geological inferences. But luck is not likely to be always on the same side in any long campaign of exploration. Where the explorer is limited in the area available to him, or limited in time or funds, his chances are less for approximating the above percentages, but whatever his chances are, they can be utilized to full advantage only by scientific work. In proportion as scientific work is ignored, his average chance, always barring luck, is reduced.

Elementary computation will show that if the explorer on any large plan of operations has a chance of getting ore in 5 per cent of the area

explored, there is an enormous percentage of profit awaiting him. The value of the ore found will, of course, show wide range, depending on its quality, location, and many other facts, but notwithstanding this range the margin of profit makes the plan a reasonably safe one. A large profit is always looked for in mining, but with this large profit there is usually recognized an equally large hazard. The Lake Superior iron district offers one of the few opportunities of which I know for large profit with a hazard so diminished by large-scale scientific operations that it is possible to estimate with reasonable certainty the chances of finding ore. This is the basis for the widespread feeling that iron ore exploration on a small scale is a big gamble, and on a large scale is safe and profitable. There are very few large companies in the Lake Superior region that have followed plans of exploration consistently through a series of years without making a profit. Out of a possible twenty chances in twenty areas they take all twenty and on an average one to two out of the twenty is successful, giving them an ample margin. Certain individuals receiving large incomes from mining properties have found it profitable to set aside yearly portions of their incomes toward exploration, with a fairly definite notion of the percentage of return which could be expected in a long campaign of expenditure of this sort. The increasing use of geological knowledge for such campaigns of exploration may be regarded as the growing recognition of the possibilities of eliminating adverse chances by scientific work. If the geologist can eliminate only one or two of the twenty chances to be taken, more than the cost of his service is saved.

*The Occurrence of Iron Ore as Related to Geologic Structure.*—Through out the Lake Superior iron country ore is found in quite definite relation to the geologic structure. As the ores rich enough to be valuable have been concentrated by water action they are found in places which are favorable to the maximum activity of the underground water. The flow of water is least through hard, dense portions and most free in the more porous parts of the formation. It is still further influenced by the attitude of the iron formation. If the structure is such as to provide pitching troughs the flow of the water is concentrated in them. The ore bodies, therefore, are found most commonly in places where pitching troughs, or broken or porous parts of the iron formation have favored the flow of underground water. These channels of flow occur in a wide variety of shapes and attitudes, and their discovery and use to guide exploration requires most careful study of the structure.

“The necessity for the most careful study of the structural geology in drilling is illustrated by the frequent failure of drills to locate ore deposits even after what seemed to be careful drilling and the subsequent discovery of the deposits either by further drilling or by mining operations. Indeed, as one comes to realize the variety and complexity of underground structural conditions, he is likely to become more and more disinclined to submit

a negative report on any property, no matter how extensively it has been drilled. This difficulty is illustrated by the ore shoots in the Geobic and Menominee districts, many of which have been missed by drilling and picked up in mining operations. Many of the ore shoots in the Vulcan member of the upper Huronian slate of Michigan pitch beneath the surface, following the axes of drag folds and it is easy for drills to pass one side or the other, or, if the drill hole is inclined, to go above or below them. On examination of drilling plats of exploration areas it is easy to see where linear shoots of ore might pass through at places not penetrated by the drilling. In fact, drilling in some of these localities is almost as uncertain as shooting a bird on the wing. There are many ways of missing the ore. As knowledge of structural conditions increases, however, adverse chances diminish, with the result that in certain areas, after the local structural problems are solved, it is possible to drill with a high degree of success.

"A higher average of success in drilling would unquestionably result if greater care were taken in the interpretation of drill records. The drill runner is often allowed to report the character of the drillings and the samples are not kept, with the result that many valuable inferences that might be drawn from the lithology, the dip and strike of bedding and cleavage, and other features are lost. Not infrequently also failure to plat drill records in such a manner that they may be considered in three dimensions may cause promising chances for ore to be overlooked.

"There has been a considerable tendency to generalize the principles of ore occurrence and in exploration to carry such principles from one district to another. As a matter of fact, although some of the basic principles are general for the region, the local variations of structure require the most careful study of each area to prevent mistakes in interpretation. When explorers of the Gogebic district, where the ores lie in regular, impervious, pitching basins, went to the Mesabi district, where the rocks are of the same age, they naturally attempted to use the same methods in exploration. But here the flatter dip of the formation, the shallowness of basins, the effect of overlying slates in ponding waters, and the unusually large influence of joints in localizing the concentration of ore made the finding of ore largely a new problem, which was solved at much expense and trouble. Recognizing the danger of carrying the method of exploration of one district into another, certain explorers have gone to the other extreme and have attempted to disregard all guides derived from the study of the structural geology, with results even more unsatisfactory than if they had been used principles developed for other districts.

"Much the greater part of the exploration of the region has been conducted without taking the fullest advantage of all geologic knowledge available, but there has been a rapidly increasing tendency to follow geologic structure and therefore an increasing demand for geologic information, as shown by the cordial support that the mining men have given to the efforts of the United States and State surveys in this region and by their considerable expenditures for private geologic surveys. Certain of the drilling companies doing contract work now have geologists on their staff to aid in the interpretation of records, notwithstanding the fact that

such interpretation is primarily in the hands of their clients. The problems of underground exploration are followed keenly, intelligently, and energetically by a large number of skilled men in the employ of mining companies, with the result that advances are being made with a rapidity which is sometimes almost bewildering. Six months may see the development of new facts requiring changes in the interpretation of the drilling of a district. The statements as to structural conditions presented in another chapter of this book may require some modification by the time the book is given to the public, because of the amount of rapidly accumulating information in the interval between the writing and the printing.\*

The formations in which the ores are found were originally either carbonate or silicate of iron—and in either case contained silica and other impurities. The ore bodies that are rich enough to mine make up but a small fraction of these formations. They owe their origin chiefly to the fact that the water circulating through them has oxidized the iron and concentrated it to some extent, and has leached out much of the silica. From this fact the intelligent explorer who recognizes an unoxidized iron formation in his drill cores—and many mining men fail to recognize the iron carbonate—continues his search to find those parts of the formation that have been oxidized and leached.

The leaching of the silica frequently reduces the volume so greatly that slump occurs. Evidence of such slump is an excellent guide to indicate the portions of a belt of iron formation most favorable for drilling.

In order to point out the different ways in which the ores occur in some of the producing ranges, and thus aid those who may wish to explore for iron ore in the area covered by this report, the following brief digest is abstracted from the descriptions in the monograph on the "Geology of the Lake Superior Region." Every person in charge of exploration should be familiar with the ways in which iron ore occurs in other parts of the Lake Superior region.

*Mesabi Range.*\*\*—The iron formation in this range has in general a gentle southward dip varying from 5° to 20°. Gentle folding is characteristic and has resulted in broad, shallow troughs, which have influenced the circulation of the underground water and localized the enrichment of the iron formation into ore. The ore bodies are broad, flat, tabular in shape, and the larger ones have their greatest extent in a direction parallel to the general strike of

\*Geology of the Lake Superior Region, C. R. Van Hise and C. K. Leith, Mon. LII, U. S. G. S., pp. 485-6.

\*\*Mon. LII., pp. 159-197.

the range. The vertical thickness of ore is generally less than 200 feet but rarely gets to be 500 feet. The horizontal dimensions vary from a few hundreds of feet to several miles. Figure 33 redrawn from Mon. LII.—shows a north-south cross-section of the range and the way in which the ore is related to the associated rocks.

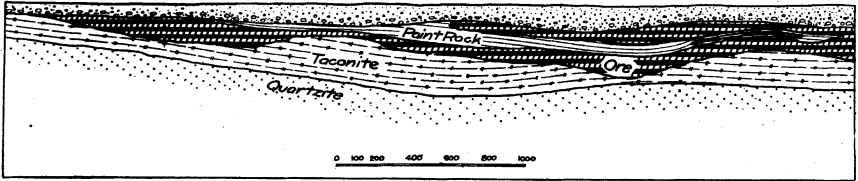

Fig. 33. Cross section showing relation of ore, iron formation (taconite) and other rocks on the Mesabi Range.

*Gogebic Range.*\*—The iron formation in the main part of this range has a strike about  $20^\circ$  north of east and a steep northward

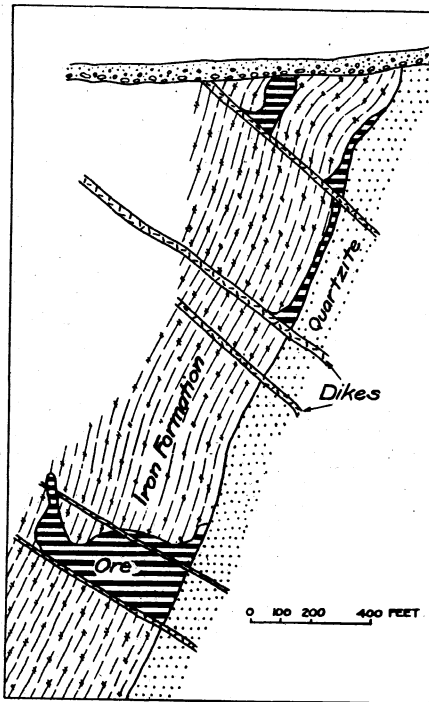

Fig. 34. Gogebic Range. Cross section showing relation of ore, dikes and foot wall quartzite.

\*Mon. LII., pp. 225-250.

dip averaging  $65^\circ$ . The formation is cut by impervious dikes, which, with the impervious footwall of quartzite, make pitching troughs. Most of these troughs have an eastward pitch varying from  $15^\circ$  to  $30^\circ$ . They have controlled the circulation of the underground water and thus localized the enrichment of the ore bodies. Figure 34—redrawn from Mon. LII.—is a north-south cross-section showing the relation of the ores to these troughs and the associated rocks. The thickness of the ore bodies varies from a few feet to 400 feet. The greatest depth to which ore is found exceeds found exceeds 2,000 feet. The length of the largest bodies is several miles.

*Vermilion Range.* †—The iron formation of this range has been most extremely folded and contorted. The ore occurs in irregular, branching, pitching troughs that change both in pitch and direction, so that even the most careful underground exploration in the mines is likely to miss ore bodies. The general strike of the range is somewhat north of east and the dip of the iron formation is always steep but usually varying within  $20^\circ$  of the vertical. Figure 35, redrawn from Mon. LII, shows cross-sections of some of the mines, and illustrates the relation of the ores to the associated rocks. Ore bodies have been found to a depth of 2000 feet. They vary in thickness from stringers too narrow to mine to bodies several hundred feet wide. The greatest length reaches several thousand feet.

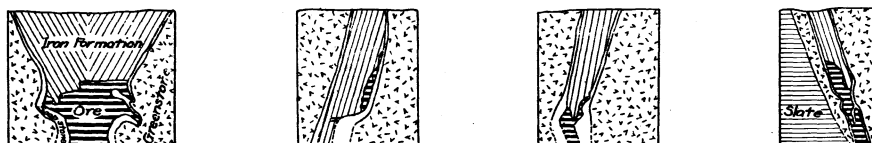

Fig. 35. Vermilion Range. Cross sections showing occurrence of ore in various mines.

*Menominee Range.* ‡—The iron formation of this range has been complexly folded, but is much less complicated than that of the Vermilion range. The main southern belt has a general strike slightly north of west and steep southward dip varying from  $60^\circ$  to  $90^\circ$ , and in some places it is overturned. The ore lies in steeply pitching folds which have concentrated the water flow. Some of these are sharp minor folds with steep pitch nearly parallel to the strike. Others are more gentle and pitch more nearly parallel to the dip. “The ore bodies \* \* \* \* may thus be in a series of

†Mon. LII., pp. 118-143.

‡Mon. LII., pp. 329-354.

parallel shoots, one pitching below the other along the strike." Such shoots have their greatest dimension steeply inclined from the horizontal and their smaller dimensions horizontal. This makes them exceedingly difficult to find with the drill. Other ore bodies are of tabular shape, resting in gentle troughs with a steep southern pitch. Figure 36 shows cross-sections of the upper part of an ore body in one of the sharp minor folds, and of one of the flat, tabular bodies.

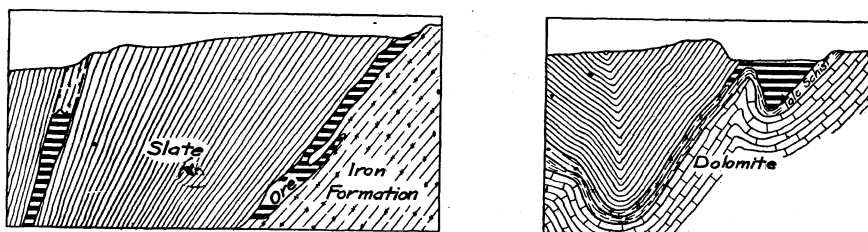

Fig. 36. Menominee Range. Cross sections showing occurrence of ore.

*Marquette District*\*.—The iron formation of this range has been complexly folded and faulted but the folding is usually more gentle and open than in the Menominee range. It has been intruded by dikes and large masses of dark colored igneous rocks, which have locally influenced the concentration of ore in somewhat the same manner as in the Gogebic range.

The soft ore bodies are found in pitching troughs or other situations where the circulation of underground water has been concentrated. The hard ores are found only near the top of the Negaunee iron formation. The various ways in which the ore is found are shown in figure 37 taken from Mon. LII. The ore bodies have been explored to a depth greater than 2000 feet. The length varies from a few hundred to several thousand feet.

*Iron River District*.—In the districts above described—excepting the Vermilion—the folding has been largely controlled by thick,



Fig. 37. Marquette Range. Ideal cross section showing various ways in which ore occurs.

\*Mon. LII., pp. 251-283.

resistant formations of quartzite or dolomite, or both. In these districts the major folding is on a large scale and fairly well indicated by outcrops of the resistant formations. In the Iron River district there is no great resistant formation to control and indicate the major structure. The iron formation is part of a thick slate formation which has been complexly folded, and in this folding process has behaved like so much clay kneaded in a gigantic pottery. The minor structures on the other ranges are very complex but in this district the major structures are as intricate as the minor structures elsewhere. Large folds branch and unite and cross each other at various angles. and are complicated by smaller folds superimposed upon them.

This range and the Vermilion are good types of the Upper Huronian and Keewatin types of iron formation. In the Keewatin, as shown in the Vermilion, the ore area is only 2.35% of the area of iron formation. In this district it has been estimated that nearly half of the 40's underlain by iron formation contain ore.

The ore bodies in the Iron River district are very irregular in form, as would be expected from the above outline of the geologic structure. In fact they are so irregular that it is practically impossible to give an adequate idea of their form by a cross-section. Furthermore, there is little magnetic attraction connected with the ores and many of the usual criteria that are so helpful in exploring elsewhere are lacking here. The result has been that nearly every 40 in the central part of the district necessarily has been looked upon as explorable ground. Notwithstanding their great irregularity the ore bodies are found to lie in situations determined by the concentration of the flow of underground water. When once an ore body is discovered it is often possible to follow its extension readily by careful study of the structure shown by the drill, and thus finding where the though lies that controls the water circulation. The ore bodies are known to extend in some cases to a depth of over 1500 feet. The greatest horizontal extent is several thousand feet.

*The Cuyuna District\**.—This district is like the Iron River district in having no quartzite or dolomite formations to control and indicate the structure, and in the large percentage of the area of iron formation which is underlain by ore. The iron formation is part of a great slate series that has been closely folded. Unlike the Iron River district, however, the folding in this district has been in a single major direction, so that there is a distinct northeast-southwest

\*Mon., LII., pp. 211-224.



linear trend to the iron formation belts. The "south range" has steep dips, both north and south, averaging  $80^\circ$ . The "north range" is not so closely folded and the dips are not so steep. The ore bodies are lenticular in shape and vary up to 125 feet in thickness in the "south range" and to 400 or 500 feet on the "north range." Practically all the ore bodies so far explored, are less than 1000 feet in depth. On the "south range" the known depth is much less than on the "north range." Some of the ore bodies are known to have a horizontal extent of two miles. The rock on this range is covered by 35 to 400 feet of glacial drift and no exposures are found. The discovery of ore was based entirely on magnetic surveys. It has been found that the ore bodies usually lie a moderate distance away from the magnetic lines and much of the early work was disappointing until this relation was discovered. Figure 38 taken from page 218, Mon. LII., shows the relations of the ore bodies to the associated rocks and to the magnetic line. Here the magnetic line is usually stratigraphically below the ore and nearly 100 feet away from it in part of its course. In other cases the magnetic line may be on the other side, or it may be directly over the ore. These relations can only be ascertained by careful tracing of the magnetic line in great detail and then drilling a row of holes across it.

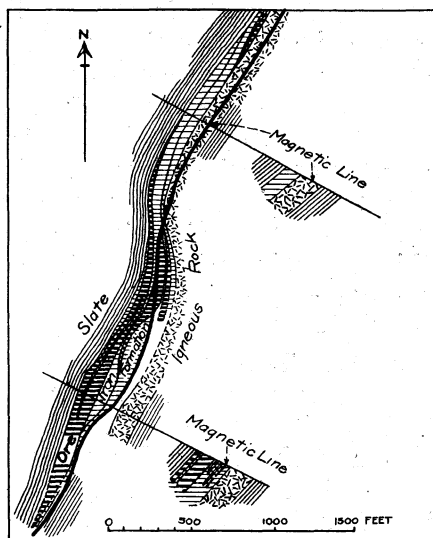

Fig. 38. Cuyuna Range. Plan showing relation of ore bodies and iron formation to the magnetic line.

*The Detailed Examination Before Drilling.*—A careful study of every geologic fact to be observed, of rock exposures, magnetic attractions, glacial drift, topography, and their relations, is a necessary preliminary to drilling if the best possible results are to be secured for the money expended. This is the second step in exploration mentioned on page 145. As quoted on page 147, "There is almost no fact relating to the structure or metamorphism, conditions of sedimentation, chemistry of deposition of the ore, factors entering into secondary concentration—no matter how apparently unrelated to practical exploration—which does not contribute to a comprehension of the possibilities in a given situation, and facilitate the finding of the ore."

This report eliminates from further consideration a great part of the lands covered. It also points out those areas worthy of a more detailed examination. It is of great importance that such areas be examined in detail before drilling is started. Such an examination is relatively inexpensive as compared to the cost of drilling, yet many people have made the expensive mistake of starting drilling operations without it. The cost of a single drill hole expended in having a thoroughly competent geologist make such an examination will almost invariably save the cost of several drill holes.

The important facts to be sought in the detailed examination of rock outcrops are the evidence they give as to the dip and strike of the beds, the nature and degree of metamorphism they have suffered, the character of the rocks—whether favorable or unfavorable to the presence of an iron formation in association with them, the degree and character of erosion they have been subject to, and whether they have been intruded by igneous rocks. From the notable scarcity of rock outcrops in this area little evidence can be hoped for from this source, but what there is should be found.

The detailed magnetic survey should consist of observations made with the dip needle—and the dial compass wherever useful—on closely spaced traverses. There are many cases where abnormal magnetic attractions are shown on the maps on a single traverse but nothing found a half mile east or west. Many of these cases will undoubtedly be found to be due to short magnetic lines ending before they reach the adjacent traverse. Furthermore the connecting of attractions found on traverses a half mile apart, as necessarily done on the township plats of this work, will sometimes be found erroneous and the true situation found to be that the lines have a different direction and the points connected are really on

different lines rather than on one. This can be found only by close work and following the magnetic lines in detail.

In doing this close magnetic work the size of the target aimed at must be borne in mind constantly. While the main purpose of the magnetic survey is served by locating an iron formation there are numerous useful hints to be obtained from it that are of great assistance in selecting places having the most promising structure in which to begin drilling. The ore body, if one is present, will probably be but a moderate number of feet in thickness across the strike, and several hundreds of feet in length; and it will most probably lie in some form of pitching trough. The traverses should be spaced closely enough to outline the structures to which an ore body may owe its origin. The positions of the pitching troughs are indicated oftentimes by minor curves of the magnetic line, which can be located only when it is crossed every few hundred feet. These curves must be examined in relation to the dip of the forma-

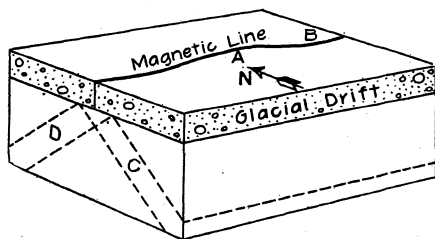

Fig. 39. Block diagram showing the meaning of curves in a magnetic line.

tion. In figure 39 either A or B might be a trough, so far as the magnetic line is concerned. If the dip is to the northward as shown at D, B would be a trough and the best place to start a drill. If the dip were southward as at C, A would be the trough and B would be a hump, and A would be the best place to drill. This illustrates the importance of getting all the evidence of the dip both from outcrops and from a careful study of the magnetic observations, as described in chapter IV. Even though the attraction may be due to a magnetic slate the structure worked out in this way is of the greatest value as a guide in exploring at a distance of many hundred feet from the magnetic line. Furthermore, it is oftentimes possible to make fairly satisfactory inferences as to the nature of the rock causing the magnetic attractions after closely spaced observations have been made.

In beginning drilling operations it is of value to get a closely approximate idea of the depth of surface, and the exact location

of the formation causing the attraction, by the method given on page 81. This will usually make it possible to spot the drill so that the first hole will strike the formation causing the attraction, and thus do away with the expense of several holes frequently necessary to find it when this method is not used. If the surface cover is found to be thin it will be possible to drill inclined holes, thus getting the maximum amount of information for the money expended. Since the formations are more or less steeply inclined a properly placed angle hole will cut a greater thickness of strata than a vertical hole of the same depth. The difficulties of drilling are such that inclined holes cannot be used when the surface is too thick.

The glacial drift in the region to be explored should be examined with care to see what evidence may be found as to the kind of rocks present in the area, and especially the character and abundance of iron formation and iron ore in the drift. All evidence available should be found which shows the direction of movement of the glaciers and permits an estimate of the distance which the boulders and pebbles of iron formation or ore have been transported. Particular care should be taken in looking for small pieces of the softer forms of ore, as their presence strongly indicates a nearby source of some magnitude, especially if they are plentiful.

The topography should be examined in a general way to find any relationship of the present forms of the surface to the surface of the underlying rock. The rock surface was determined largely by the drainage lines that existed before the covering of glacial drift was deposited. These preglacial drainage channels had rather thoroughly adjusted themselves to the rocks so that they are found chiefly in the less resistant parts, while the more resistant formations made the divides between them. These old valleys therefore usually mark the areas of slate and of associated rocks in which iron formations are most likely to occur. They are more or less completely obscured by the glacial drift at present, and careful work by an experienced observer is necessary to find any evidence on which to determine their location.

The topography of the area immediately along the line which it is proposed to explore should be examined in detail to identify, if possible, any depressions caused by the slump of glacial drift over the depressions which resulted when the ore was enriched by leaching out the silica, as described on page 151. Depressions of this sort are seldom definitely identifiable, but the association of ore

bodies with slight depressions is so common that a slight depression is a better place to explore than a slight elevation, if all other indications are equal.

*Methods of Underground Exploration.*—The various methods of underground exploration are test pitting, drilling—either with a churn drill or a core drill—and running drifts and cross-cuts from mine workings or prospect shafts. Under the following subhead exploration by means of drills is discussed at length, as this is the method that will necessarily be used in most cases in this district. The directions given for the placing of drills apply equally well to the placing of test pits or prospect shafts. Test pits are the cheapest method of exploring where the drift cover does not exceed 50 to 100 feet if the conditions are such that they can be used. In some cases where ore is found in a test pit it may be advisable to sink deeper and run drifts and cross-cuts to determine the size of the ore body.

*Drilling.*—After all of the information to be had by a detailed surface examination is at hand, the place to start the drill is determined upon. If the general structure and nature of the iron formation is known from the surface examination, the first purpose of the drilling should be to find the position and extent of the oxidized and enriched parts and thus eliminate the barren parts. But the usual case is that after a surface examination there still remains much of the geological succession and structure that must be determined by the drill. The first hole should be so placed as to penetrate, if possible, the formation causing the magnetic attraction. The proper place for this hole is not necessarily on the line of maximum attraction but is likely to be a short distance to one side or the other, depending on the dip and strike of the formation. The closest possible determination of the place can be made by the method described on page 81. The method of drilling may be influenced by the information thus gained as stated on page 157. This hole may show that the cause of the attraction is schist, slate, greenstone, granite, or iron formation or any other kind of rock—for almost any kind of rock may contain sufficient magnetite to cause local attraction. If iron formation is found a few holes should determine whether it is the highly productive type like the Iron River formation, or whether it is like the less productive Vermilion type. If the rock is bedded the drill should penetrate it for a sufficient depth to show the angle of dip, unless conditions are

such that it appears desirable to use a churn drill and only test the character of the ledge. If the rock is massive granite, or highly anamorphosed rock of any kind, there is little use of further drilling, but if it is almost any other kind of rock a succession of holes—a cross-section—should be drilled to see if an iron formation is present. The distance at which the hole should be spaced in the first cross-section must be determined by local considerations but ordinarily they should not be more than 400 or 500 feet apart. If an iron formation is penetrated the holes should be spaced closely enough to give a good knowledge of its strike, dip, character, and the degree to which it has been altered. When the oxidized and enriched part of the formation is found drilling should be continued along the strike, making complete cross-sections and penetrating it at different depths.

It will be noticed from the above that the first thing sought is geological information rather than ore. The finding of ore in the first cross-section can be nothing but pure luck. After the geological information is available future drilling can be planned more intelligently and the element of luck reduced to a minimum. If the knowledge of the geologic facts only increases the chances of finding ore from 2% to 4% it has saved half of the drilling, or in other words, has increased the chances 100%, and better results than this can usually be secured.

In order to accomplish this it is necessary to preserve all drill cores and to carefully plot the drill holes so the geologic structure can be seen in three dimensions—thus enabling the person in charge to see all possible relations. The too common practice of throwing away all drill core except that which the drill man thinks rich enough for assaying means nothing less than throwing away the greatest part of the information that is paid for. After a few holes have been drilled it is usually possible to work out details of structure which enable the person in charge to spot drills in the most advantageous way—getting a maximum amount of information for the minimum expenditure. Too much emphasis, therefore, cannot be laid on the importance of saving all drill cores and taking advantage of every bit of geologic information shown by the drill.

*Lands to Explore in this Area.*—Each township description in Part II includes a paragraph on exploration. In making the recommendations in these paragraphs all the information obtained in the neighboring townships is taken into account. Any person contemplating exploration in the area covered by this report

should study carefully these township maps and descriptions and should also study chapter IV., so as to interpret the magnetic data shown on the maps.

All lands in classes A and B, and most of those in class CI present more or less favorable chances for the discovery of iron ore, and are worthy of further detailed surface examination. While this detailed examination will eliminate many of them from further consideration, it will show many places worthy of being drilled. Nearly all the favorable recommendations are based on magnetic data. However, the idea must not be entertained that lands with no magnetic attraction cannot contain ore. Large areas of non-magnetic lands in the Iron River district contain ore, and there may be large ore bodies in the non-magnetic parts of northern Wisconsin. The difficulty is that ores which cause no local magnetic attraction offer no other indication of their presence underneath a thick cover of glacial drift, and so drilling for them is a stab in the dark and offers very little chance of success. If ore is once found in a non-magnetic area, either by a well or, by a fortunately placed drill, it affords a definite start from which large areas of non-magnetic land may be explored with profit; but until ore or indications of ore are actually found very little exploration is warranted on such lands. The magnetic lines afford a definite starting place, and so with a few exceptions only those lands lying along them are recommended for exploration.

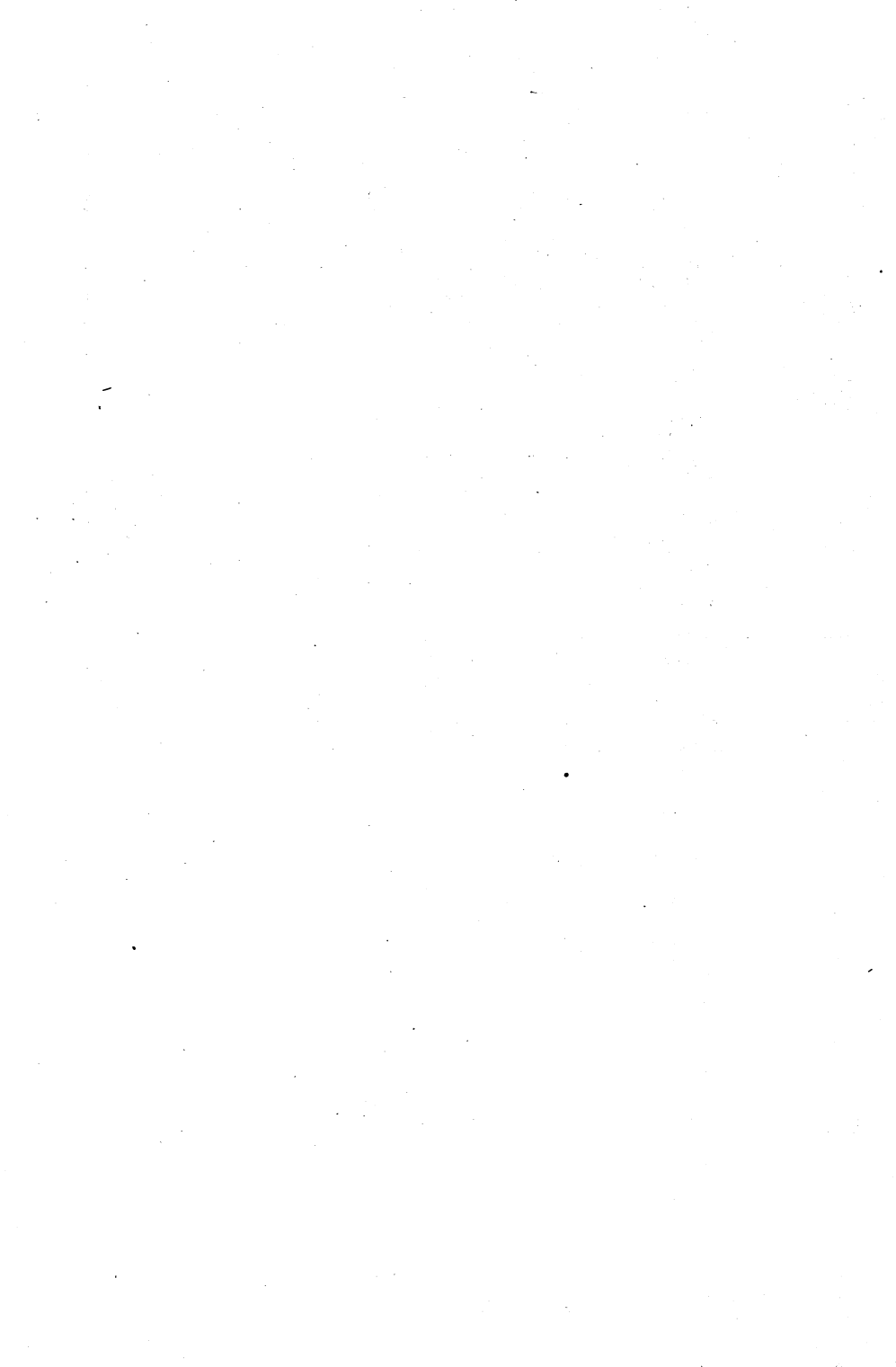



## **PART II**

### **TOWNSHIP MAPS AND DESCRIPTIONS**

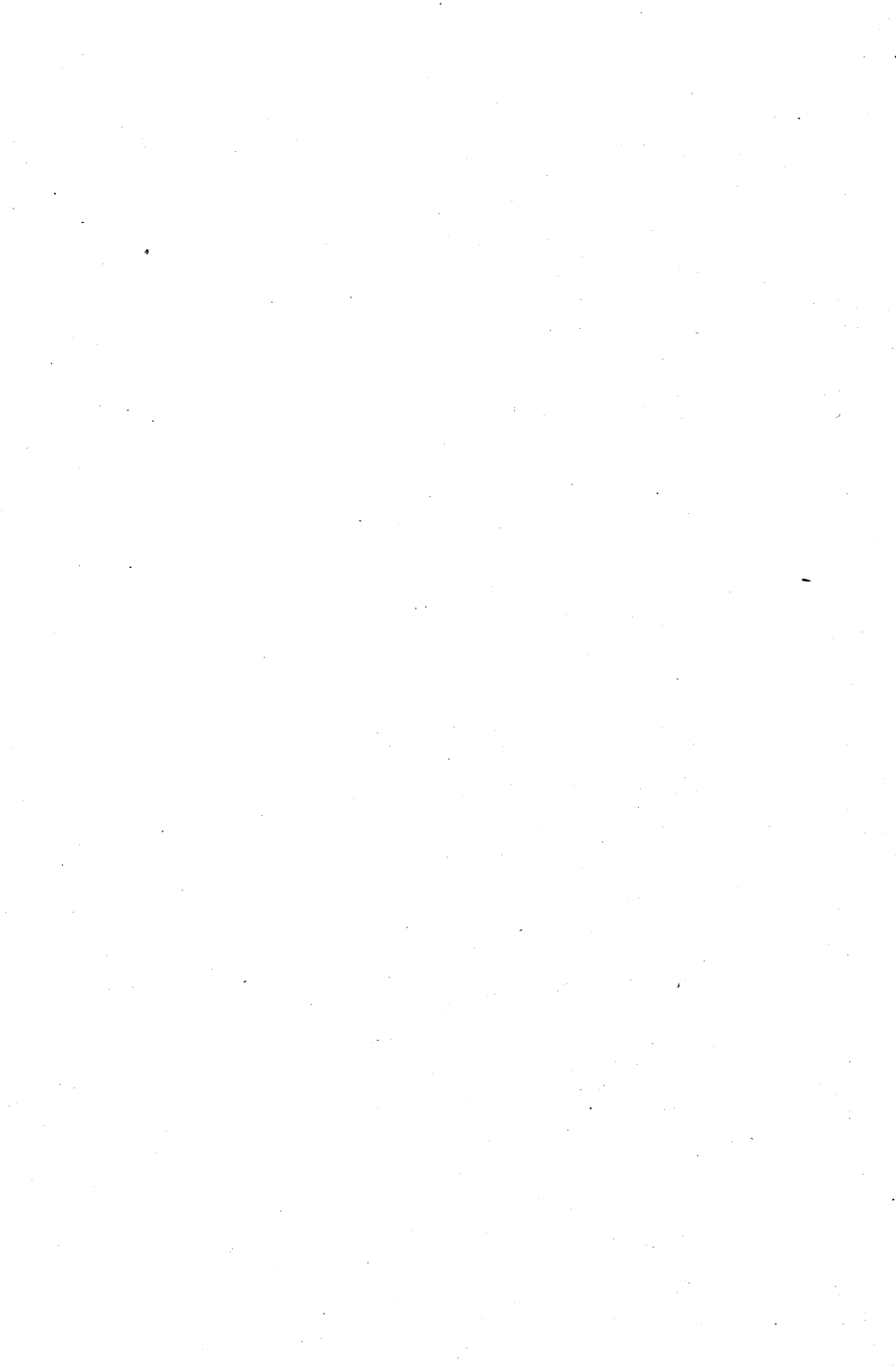

## TOWNSHIP 32 N., RANGE 7 W.

*Surface Features.*—This township presents a variety of topographic features. In the northwestern part are several sections of nearly flat, poorly drained land, which slope upward toward a gently undulating area to the southeast. Over much of the southern half extremely rugged knob and basin topography is found. This is less pronounced in the east side of the township, however, and here some nearly level areas are found. In the northeastern part Flambeau Ridge is a striking topographic feature. It is about  $3\frac{1}{2}$  miles in length and rises to a height of 300 to 400 feet above the surrounding country. The ridge is broken by a gap in the middle of section 1, which undoubtedly was the channel of a large river in preglacial times. Since being abandoned as a river channel the valley has been filled with an unknown thickness of glacial drift, so that gap is now slightly higher than the general elevation of the country around the ridge.

The accompanying profile shows the topography, as Flambeau Ridge is approached from the south. The elevations given here for the ridge were taken along the road which crosses at a point estimated to be about 100 feet lower than the highest point on the ridge farther west. A distant view of the ridge from the north is given in plate VIII.

Roads in this township are very little improved, and as usual with dirt roads, are very poor in wet weather. During the dry seasons they are good. The best and most used road runs north and south a mile west of the east line and turns east to cross the ridge at the gap in section 1.

Very little timber remains in this township, but there are a few scattered patches of hardwood. Settlement has been very slow, probably in part because of the distance from railroad and in part because of the rough topography. There is still a large amount of very good unimproved land.

*Glacial Drift.*—Northwest of a line connecting the N.  $\frac{1}{4}$  S. of section 4 and the southwest corner of section 7, is a flat area of out-

wash material which is mostly swamp. Some low sand hills rise above the undrained part. The southeast corner of section 12, the E.  $\frac{1}{2}$  of section 13, all of section 24 and a small part of the adjoining sections 23, 25, and 26, is an area of ground moraine largely covered with outwash. The glacial material here consists of sand, gravel and some boulders. All the remainder of the township is covered with terminal moraine deposits varying from nearly level hilltops to very rugged slopes. The materials are sand, silt, and gravel with some clay. Large boulders are numerous in places. Flambeau Ridge is in this area, but extends far above the general level of the terminal moraine and is itself covered by a veneer of glacial drift varying from nothing to possibly as much as several hundred feet in the gap in section 1. The drift will show great variations in thickness, but except along Flambeau Ridge it will undoubtedly be deep, possibly from 100 to 200 feet, or even more in the southwestern part. Wells are generally shallow and none of them reach ledge.

*General Geology.*—The outcrops in this township are confined to sections 1, 2, 11 and 12 and are all on Flambeau Ridge. Some exposures in section 6 in the township to the east are shown on the accompanying map because they have a bearing on the structure of the ridge and no map of that township was made. All of the rocks are quartzite or conglomerate. The conglomerate occurs principally at the base of the formation, but stringers are found throughout the entire thickness of exposed rock. It consists of pebbles varying from  $\frac{1}{4}$  inch to 3 inches in diameter, which lie in a matrix of reddish quartz sand. In places the pebbles make up nearly the entire volume of the conglomerate, whereas in others they are found several inches apart. Most of the pebbles are vein quartz but others are porphyry and iron formation in notable quantity, and granite and slate in lesser quantity. Where not conglomeratic the quartzite is composed of rounded quartz grains as a rule very thoroughly cemented. It varies in color from white through pink and brick-red to purplish; most of it is dark red.

The outcrops located are shown with strike and dip on the accompanying map. (Note: The  $5^\circ$  dip shown in the N. E.  $\frac{1}{4}$  of the S. E.  $\frac{1}{4}$  of section 1 should be  $35^\circ$ .) The quartzite on the line between sections 11 and 12 is very much brecciated and recemented with vein-quartz. At this point bedding is not distinct but the rock appears to strike S.  $60^\circ$  E., and dip  $85^\circ$  N. Elsewhere the bedding is fairly good and well developed cross-bedding is shown in places. In all instances this cross-bedding gives undoubted evidence that the top

of the formation lies to the north. It also indicates that the predominant direction of the currents causing it was from a southerly direction. The exposure occurring in section 2 is of a rather finer grained quartzite and contains at its base a number of pieces of red slate varying up to 4 inches in length and  $\frac{1}{2}$  inch thick. Between this outcrop and those lying to the south is a depression which suggests that a softer formation may occupy this intervening space. Here as well as in the outcrops to the south the strike is nearly east and west and the dip  $85^\circ$  to the north. The younger beds are on the north.

At the east end of the quartzite the strike varies from northeast, on the south side, through north, to north  $15^\circ$  west on the north and the dip varies from  $35^\circ$  to  $70^\circ$ , always toward the west. The base is to the east where a thick conglomerate is developed.

Structurally this ridge is a monocline bent in the form of a hook on the east end and represents the remnant of a syncline.

The total thickness of rock exposed in contiguous outcrops does not exceed 600 feet, but the thickness estimated by measuring the distance between the most northerly and the most southerly outcrops in the straight monoclinical portion of the ridge, is believed to be at least 2,000 feet.

There are no outcrops to indicate the character of the rocks in the remainder of the township but it is probably underlain by schists with intrusives of acid igneous rocks similar to the formations to the east on the Chippewa River at Holcombe and south.

*Magnetic Observations.*—A general discussion of magnetic observations and their significance is given in chapter IV. In the southeastern part of the township is an area of rather mild and irregular attraction which is believed to indicate the presence of magnetic schists. Basic schists outcrop about 3 miles east in the vicinity of Holcombe and show attractions very much the same as those found in this township. The dashed lines in sections 25 and 26 may indicate lines of strike.

*Land Classification.*—The principles of land classification employed in this work are discussed in Chapter V. Lands known or believed on very good evidence to be underlain by the quartzite are placed in class D. Lands north of the quartzite are classed as C1 since this quartzite is believed to be of Huronian age and consequently may have iron formation associated with it. All other lands are placed in class C2.

*Exploration.*—While this survey has shown no iron formation and the results are such that none of this township can be especially recommended for exploration, there is a reasonable chance that iron formation may be present on the north side of Flambeau Ridge. This quartzite is probably of Huronian age and the structure is a synclinal remnant as indicated under the discussion of general geology. Thus conditions are approximately the same as in most of the iron ranges of Michigan and Wisconsin and it is quite possible that north of the quartzite there may be the slate and iron formation so frequently found in such associations. It is believed that this is certainly the most favorable place for exploration in this township.

Much of the work done in exploration for iron ore is wasted because of failure to make intelligent use of the geologic and magnetic data to be obtained by a careful preliminary survey and because the geologic information given by the drill is not properly used as a guide for further work. The value of careful scientific methods of exploration therefore cannot be too strongly emphasized. If exploration is contemplated in this township the discussion of this subject in chapter VI should be carefully studied.

TOWN 32 N., R. 7 W.

Survey Made in May, 1914

Under the Direction of

W. O. HOTCHKISS, State Geologist

AND

E. F. BEAN and O. W. WHEELWRIGHT,  
in charge of Field Parties

BY

O. W. WHEELWRIGHT, Chief of Party

O. W. POTTER, Asst. Geologist

HOWARD QUINLAN, Asst. Geologist

SYMBOLS AND ABBREVIATIONS.

The symbols and abbreviations used on this map are explained in Chapter II.

TOWN AND RANGE LINES.

In constructing this map the south line of the township was laid off as a true east west line. The other boundary lines were then laid off with the lengths shown on the Land Survey plat. Some of the maps are therefore incorrect in shape but this is necessary because definite facts are lacking. The acreage of part of the lots in the north and west tier of sections is shown to give a check on the distances in these sections.

LOCATIONS.

All locations are based on pacing traverses from government land corners. In many cases these were not found and it was necessary to continue the traverse several miles without a check. Locations of certain features may therefore be somewhat wrong. In such cases the feature sought may best be located by its relation to a stream, swamp, lake, or other feature shown on the map.

PROFILES.

The locations of the profiles are shown on the map by dashed blue lines with black letters at the ends. Railroad profiles were furnished by the companies and show elevations of the ground rather than track in most cases; others are from road surveys by the State Highway Commission; most of them are hand level lines made by this Survey. Wherever possible the elevations above sea level are given. These elevations vary from 1050 to 1770 feet. A local datum plane was necessarily assumed in some cases. These cases are identifiable by the fact that the base line is always numbered 0.

LAND CLASSIFICATION.

This is shown on the map by the blue letters. It is explained in the following township description and at length in chapter V.

MAGNETIC DATA.

Dial compass readings are shown in blue figures. Eastward declinations are shown with a dot to the east and westward with a dot to west of the number. Dip needle readings are shown in black. All are positive except those preceded by the negative sign. All readings show deviation of needles from the normal reading of the instrument used. Normal readings are omitted from the map except at each quarter section corner. All abnormal readings are shown.

Traverses were made on lines indicated—usually the N-S section and quarter lines. Dip needle readings were taken each 50 paces, dial compass readings each 100 paces when sun permitted.

Magnetic lines are indicated by heavy black lines, solid where definite and dashed where doubtful.

CAUTION: Almost any kind of rock may be the cause of magnetic attraction. Do not fail to read the following description of this township, and also chapter IV., in which the magnetic attractions are discussed.

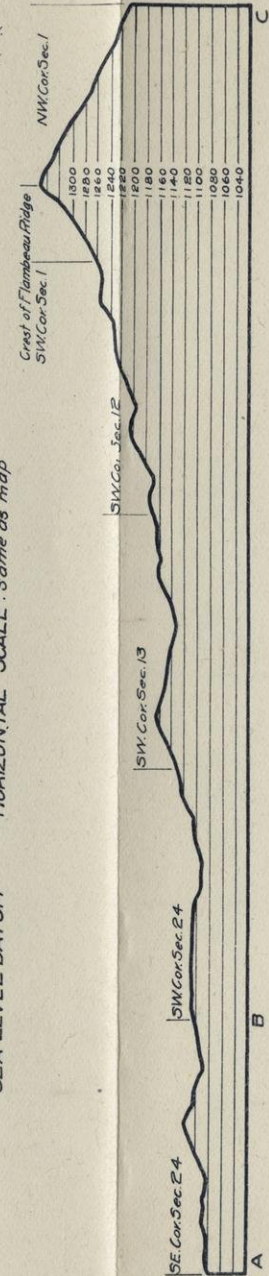
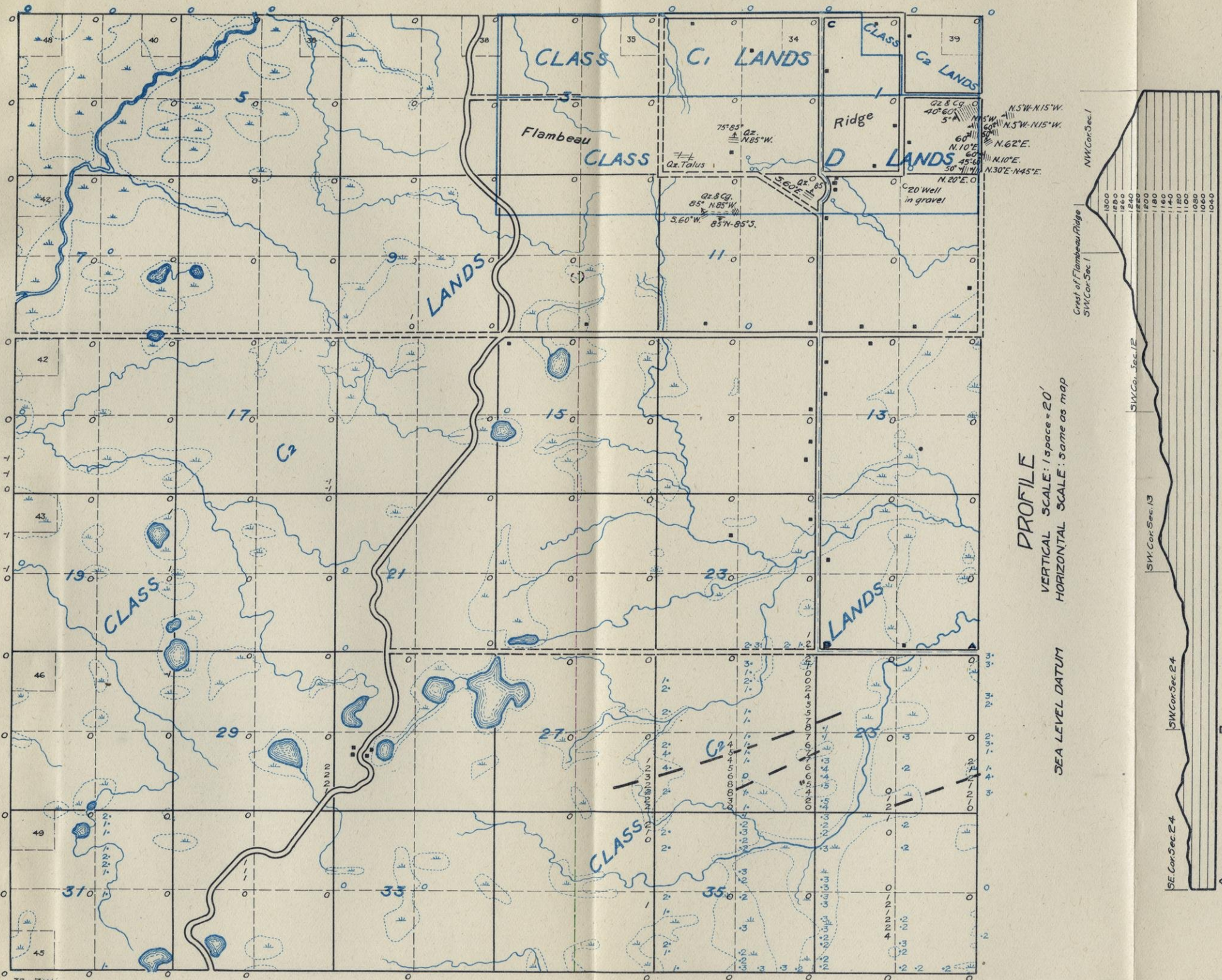

PROFILE  
VERTICAL SCALE: 1 space = 20'  
HORIZONTAL SCALE: Same as map  
SEA LEVEL DATUM

## TOWNSHIP 33 N., RANGE 6 W.

*Surface Features.*—This township is characterized by gently undulating topography except for a belt of somewhat more pronounced hills one half to one mile wide extending across it in an east-west direction, 1 mile north of the south line.

The roads are of recent construction and usually follow the section lines. Most of them are well graded and generally in good condition. The main road running north and south throughout the center of the township leads to Ladysmith and is exceptionally good. Practically all the timber has been removed except a small amount in sections 35 and 36.

*Glacial Drift.*—The entire township is covered with ground moraine. This is generally very level, but is slightly rolling in places. The materials composing the drift are sand and silt, with boulders generally distributed but not numerous as a rule. The northern third is less sandy than the remainder.

The depth of the drift covering is believed to be very moderate. Rocks are exposed in section 25 and along the west line of the township near the northwest corner of section 19, and in a well and several shallow pits in sections 15 and 16. The ledge has not been uncovered in any other localities, but it is believed that the depth of the drift will not often exceed 50 feet.

*General Geology.*—An outcrop of fine-grained granite gneiss occurs along Main Creek 200 paces south and 200 paces east of the N.  $\frac{1}{4}$  post of section 25. Two hundred paces south of the northwest corner of section 19 is an outcrop of highly vitrified quartzite. This has been badly brecciated and re-cemented with many quartz veins, and contains quartz druses. The exposure consists only of a mass of broken blocks which give no clue to its structure.

A well 450 paces north of the southeast corner of section 16 penetrated a mashed porphyry at a depth of about 30 feet. The rock is very schistose, light-colored, and in many places stained bluish green by copper minerals. The copper is very unevenly distributed. Two samples taken from this well were assayed with the following results:

Sample No. 1. Silver, 1 oz. per ton; copper,  $\frac{3}{4}$  of 1%

Sample No. 2. Silver, 1 oz. per ton; copper, none.

These mineral values are not sufficient to make this a workable deposit but judging from the leached appearance of the rock, there is some chance for greater concentration with depth. Other shallow



pits near the school house  $\frac{1}{4}$  mile north show similar rock but the presence of copper is less evident.

No relations between the three formations in the township were found. The porphyry and quartzite are both highly metamorphosed and are probably older than the granite. It is impossible to outline the area covered by any of these formations or to state whether other formations are present. If iron formation is present it exhibits no evidence of the fact.

*Magnetic Observations.*—No abnormal readings of the dip or dial compasses were found in this township.

*Land Classification.*—The principles of land classification employed in this work are discussed in Chapter V. The 40 acre tract at the granite outcrop is placed in class D. All other lands in the township are placed in class C2 but are not considered to be among the most favorably situated lands in this class.

*Exploration.*—While the existence of iron formation is not improbable exploration for iron ore does not seem warranted in the light of present information. The immediate vicinity of the quartzite outcrop in section 19 probably offers the most favorable prospect for iron since this rock is of a type frequently associated with iron formations in the Lake Superior country. The copper prospect in section 16 does not offer particular encouragement but there is a possibility, not yet disproven, that metals in paying quantities may exist. The rock appears most heavily mineralized at the well above mentioned and a small amount of work seems warranted in sinking this well deeper and possibly drifting or cross-cutting if any evidence of concentration is found at greater depth.

# TOWN 33 N., R. 6W.

Survey Made in August, 1914

Under the Direction of

W. O. HOTCHKISS, State Geologist

AND

E. F. BEAN and O. W. WHEELWRIGHT,  
in charge of Field Parties

BY

W. I. ROBINSON, Chief of Party

S. M. WILLIS, Asst. Geologist

G. M. SCHWARTZ, Asst. Geologist

## SYMBOLS AND ABBREVIATIONS.

The symbols and abbreviations used on this map are explained in Chapter II.

## TOWN AND RANGE LINES.

In constructing this map the south line of the township was laid off as a true east west line. The other boundary lines were then laid off with the lengths shown on the Land Survey plat. Some of the maps are therefore incorrect in shape but this is necessary because definite facts are lacking. The acreage of part of the lots in the north and west tier of sections is shown to give a check on the distances in these sections.

## LOCATIONS.

All locations are based on pacing traverses from government land corners. In many cases these were not found and it was necessary to continue the traverse several miles without a check. Locations of certain features may therefore be somewhat wrong. In such cases the feature sought may best be located by its relation to a stream, swamp, lake, or other feature shown on the map.

## PROFILES.

The locations of the profiles are shown on the map by dashed blue lines with black letters at the ends. Railroad profiles were furnished by the companies and show elevations of the ground rather than track in most cases; others are from road surveys by the State Highway Commission: most of them are hand level lines made by this Survey. Wherever possible the elevations above sea level are given. These elevations vary from 1050 to 1770 feet. A local datum plane was necessarily assumed in some cases. These cases are identifiable by the fact that the base line is always numbered 0.

## LAND CLASSIFICATION.

This is shown on the map by the blue letters. It is explained in the following township description and at length in chapter V.

## MAGNETIC DATA.

Dial compass readings are shown in blue figures. Eastward declinations are shown with a dot to the east and westward with a dot to west of the number. Dip needle readings are shown in black. All are positive except those preceded by the negative sign. All readings show deviation of needles from the normal reading of the instrument used. Normal readings are omitted from the map except at each quarter section corner. All abnormal readings are shown.

Traverses were made on lines indicated—usually the N-S section and quarter lines. Dip needle readings were taken each 50 paces, dial compass readings each 100 paces when sun permitted.

Magnetic lines are indicated by heavy black lines, solid where definite and dashed where doubtful.

**CAUTION:** Almost any kind of rock may be the cause of magnetic attraction. Do not fail to read the following description of this township, and also chapter IV., in which the magnetic attractions are discussed.



## TOWNSHIP 33 N., RANGE 7 W.

*Surface Features.*—The topography in this township is generally level, varying to slightly undulating east of the Flambeau River. A few somewhat rougher places are found in sections 1, 2, 3, 7, 8, 12, and 22. South of the Chippewa River in sections 34, 35, and 36 the ground rises rather gently toward Flambeau Ridge and reaches a considerable elevation above the general level of the township. Drainage is very poor in the flatter part of the township and numerous swamps and a few small lakes are found.

The maximum relief is not more than 100 feet and is generally very much less than this. The elevation of the mouth of the Flambeau River, as determined by river surveys, is 1050 feet above sea level.

The roads are generally good because of their sandy nature, although but few of them have been graded or much improved. The most traveled road is that running along the west side of the Flambeau River from Flambeau to Bruce.

Although this township contains much good land, settlement is progressing slowly, probably because of the distance from the railroad. Nearly all of sections 34, 35, and 36 are cleared, and a number of good farms are located along the river. Sheep raising is engaged in extensively. A few settlers are found elsewhere as well.

*Glacial Geology.*—A flat, poorly drained outwash plain occupies all of the township west of Flambeau River except sections 3 and 4. Two views of this plain are shown in Plate VIII. It extends about a half mile east of the river as far south as the center of section 27, then curves to the southeast corner of section 27 and continues in a narrow strip along the river. South of the Chippewa River and east of the mouth of the Flambeau is an undulating area of terminal moraine extending back to Flambeau Ridge. That part of the township north and east of the outwash plain, is gently undulating ground moraine. In its northern part some rough ground is found.

The glacial deposits are sand and gravel, with some silt and occasional large boulders in the outwash area; silt and sand, with boulders, in the ground moraine; and silt, clay, gravel and boulders, in the terminal moraine.

The thickness of the drift in this township is not known, nor is there much information upon which to base an estimate. Ledge is exposed on high ground in section 24, which suggests very thin drift in the east side of the township. A well at the school-house in sec-

tion 36 was drilled to a depth of 65 feet without reaching ledge. Probably the thickness of the drift will be found in general to exceed this.

*General Geology.*—An outcrop of quartzite was found about 200 paces south of the northeast corner of section 24. It consists merely of numerous blocks of broken rock covering an area of 150 paces long in an east and west direction. The rock is a very highly vitrified quartzite which has been much brecciated and re-cemented by quartz veins. In its present condition the quartz veins compose a very large percentage of the rock. This single outcrop gives very little clue to the character of the rock which underlies the remainder of the township. However, since the only rock known is a sediment, it indicates that sediments of Huronian age may exist generally over the township, in which case the prospects for iron formation should be fair. Flambeau Ridge, a quartzite syncline, lies just south, but it is not possible to say whether or not this quartzite exists under the surface in this township. Probably it does not.

*Magnetic Observations.*—A general discussion of magnetic observations and their significance is given in Chapter IV. This should be carefully studied before attempting to interpret the readings shown on the map. Mild magnetic attraction was found in several places in this township. The belt in sections 2, 3, and 10 continues in the township north. The attraction is not definite enough to constitute a line but may indicate the trend of a magnetic formation.

A poorly defined line of very mild attraction is found in sections 7 and 18 and is continuous with a more definite line in the township to the west.

A small area of very mild attraction just north of the Chippewa river at the mouth of the Flambeau attracts attention because of its location with reference to the quartzite of the Flambeau Ridge. It may mark an iron formation which is only locally magnetic.

*Land Classification.*—A general discussion of the principles of land classification is given in Chapter V. Information in this township is so meager as to make definite classification impossible. The only rock found outcropping is a highly metamorphosed sediment of a type commonly associated with iron formation which is a favorable indication. The lands along the magnetic line in sections 7 and 8 are classified as C 1. All other lands are placed in class C 2, but it is recognized that they offer better prospects for iron ore than many others in this class.

# TOWN 33 N., R. 7W.

Survey Made in May, 1914

Under the Direction of

W. O. HOTCHKISS, State Geologist

AND

E. F. BEAN and O. W. WHEELWRIGHT,  
in charge of Field Parties

BY

O. W. WHEELWRIGHT, Chief of Party  
GEO. NISHIHARA, Asst. Geologist  
O. W. POTTER, Asst. Geologist  
HOWARD QUINLAN, Asst. Geologist

## SYMBOLS AND ABBREVIATIONS.

The symbols and abbreviations used on this map are explained in Chapter II.

## TOWN AND RANGE LINES.

In constructing this map the south line of the township was laid off as a true east west line. The other boundary lines were then laid off with the lengths shown on the Land Survey plat. Some of the maps are therefore incorrect in shape but this is necessary because definite facts are lacking. The acreage of part of the lots in the north and west tier of sections is shown to give a check on the distances in these sections.

## LOCATIONS.

All locations are based on pacing traverses from government land corners. In many cases these were not found and it was necessary to continue the traverse several miles without a check. Locations of certain features may therefore be somewhat wrong. In such cases the feature sought may best be located by its relation to a stream, swamp, lake, or other feature shown on the map.

## PROFILES.

The locations of the profiles are shown on the map by dashed blue lines with black letters at the ends. Railroad profiles were furnished by the companies and show elevations of the ground rather than track in most cases; others are from road surveys by the State Highway Commission; most of them are hand level lines made by this Survey. Wherever possible the elevations above sea level are given. These elevations vary from 1050 to 1770 feet. A local datum plane was necessarily assumed in some cases. These cases are identifiable by the fact that the base line is always numbered 0.

## LAND CLASSIFICATION.

This is shown on the map by the blue letters. It is explained in the following township description and at length in chapter V.

## MAGNETIC DATA.

Dial compass readings are shown in blue figures. Eastward declinations are shown with a dot to the east and westward with a dot to west of the number. Dip needle readings are shown in black. All are positive except those preceded by the negative sign. All readings show deviation of needles from the normal reading of the instrument used. Normal readings are omitted from the map except at each quarter section corner. All abnormal readings are shown.

Traverses were made on lines indicated—usually the N-S section and quarter lines. Dip needle readings were taken each 50 paces, dial compass readings each 100 paces when sun permitted.

Magnetic lines are indicated by heavy black lines, solid where definite and dashed where doubtful.

**CAUTION:** Almost any kind of rock may be the cause of magnetic attraction. Do not fail to read the following description of this township, and also chapter IV., in which the magnetic attractions are discussed.

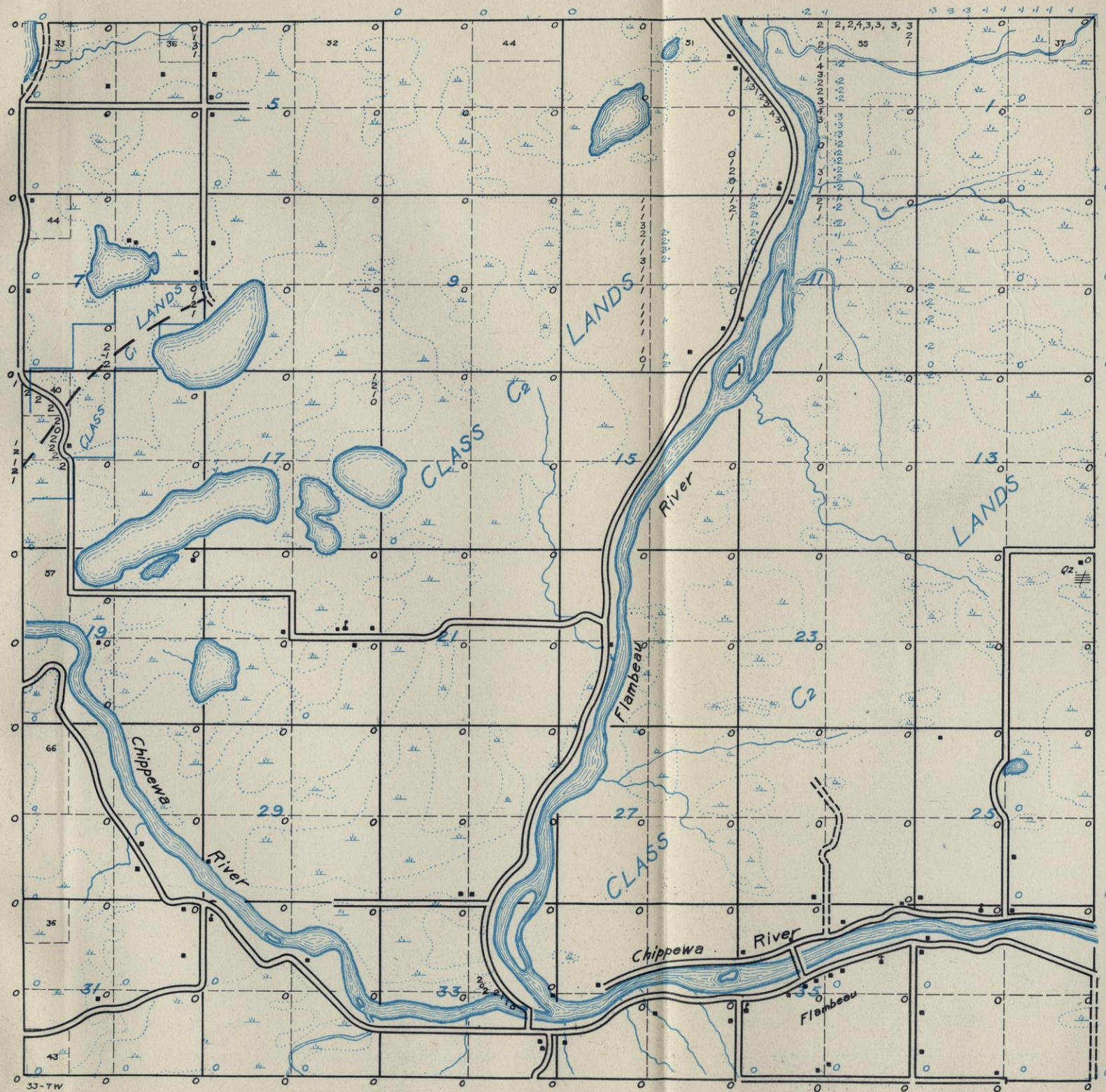

*Exploration.*—The survey made in this township shows no positive indication of iron formation and no particular tract of land can be especially recommended for exploration. If any exploratory work is done it should be in the magnetic areas, or in section 24 near the quartzite outcrop. The results of any work which may later be done on the magnetic lines in this general area will have an important bearing on the prospects for finding ore in this township and it is possible that these lands may appear to be much better prospects later on. Much of the work done in exploration for iron ore is wasted because of failure to make intelligent use of the geologic and magnetic data to be obtained by a careful preliminary survey, and because the geologic information given by the drill is not properly used as a guide for further work. The value of careful scientific methods of exploration therefore cannot be too strongly emphasized. If exploration is contemplated in this township the discussion of this subject in Chapter VI should be carefully studied.

## TOWNSHIP 33 N., RANGE 8 W.

*Surface Features.*—The greatest part of this township is of low relief. The central and eastern part is nearly flat. To the south and west of this is a belt of somewhat roughly undulating topography. The western portion is flat to gently undulating.

In the accompanying profiles, A-B shows the rougher topography southeast of Island Lake, while C-D is quite typical of the flat plain northeast of Island Lake. The roads in the more level areas are in good condition. The Bruce-New Auburn road, extending from the northern part of section 2 to the southwestern part of section 32, is the main road of the township. Except in some of the areas of rougher topography, all of the timber has been cut. Farming has developed to some extent but the proportion of cleared land is as yet quite small.

*Glacial Drift.*—In the eastern and central parts of this township is a flat outwash plain. Extending from section 35 to Island Lake, thence northward through sections 20, 17, 8, 4, and 5 is a terminal moraine belt with sags and knobs. West of this belt is an area of flat to undulating ground moraine. The glacial deposits are largely sand in the outwash area, silt and sand in the ground moraine, and sand and gravel with boulders in the terminal moraine.

The thickness of drift in this township is known only in the S. E.  $\frac{1}{4}$  of the N. E.  $\frac{1}{4}$  of section 4, where sandstone is reached at a depth of 60 feet. It seems probable that the thickness, except along drainage lines, seldom exceeds 75 feet. If the present streams follow preglacial channels, and this seems extremely likely, the drift cover in stream valleys is at least 100 feet in thickness.

*General Geology.*—No outcrops were found in this township and no information was obtained as to the nature of the underlying rock except in the northeastern part where there appears to be a thin covering of Cambrian sandstone. This was encountered at a depth of 60 feet in a well in section 4. As a result of the magnetic work it is believed that Huronian rocks underlie most of the township and the presence of iron formation is not unlikely.

*Magnetic Observations.*—A general discussion of magnetic observations and their significance is given in Chapter IV. This should be carefully studied before attempting to interpret the readings shown on the map. Over a large part of the township irregular dip

TOWN 33 N., R. 8 W.

Survey Made in June, 1914

Under the Direction of  
W. O. HOTCHKISS, State Geologist  
AND  
E. F. BEAN and O. W. WHEELWRIGHT,  
in charge of Field Parties

BY  
LOUIS ROARK, Chief of Party  
J. P. GOLDSBERRY, Asst. Geologist  
GEO. BELCHIC, Asst. Geologist

**SYMBOLS AND ABBREVIATIONS.**  
The symbols and abbreviations used on this map are explained in Chapter II.

**TOWN AND RANGE LINES.**  
In constructing this map the south line of the township was laid off as a true east west line. The other boundary lines were then laid off with the lengths shown on the Land Survey plat. Some of the maps are therefore incorrect in shape but this is necessary because definite facts are lacking. The acreage of part of the lots in the north and west tier of sections is shown to give a check on the distances in these sections.

**LOCATIONS.**  
All locations are based on pacing traverses from government land corners. In many cases these were not found and it was necessary to continue the traverse several miles without a check. Locations of certain features may therefore be somewhat wrong. In such cases the feature sought may best be located by its relation to a stream, swamp, lake, or other feature shown on the map.

**PROFILES.**  
The locations of the profiles are shown on the map by dashed blue lines with black letters at the ends. Railroad profiles were furnished by the companies and show elevations of the ground rather than track in most cases; others are from road surveys by the State Highway Commission: most of them are hand level lines made by this Survey. Wherever possible the elevations above sea level are given. These elevations vary from 1050 to 1770 feet. A local datum plane was necessarily assumed in some cases. These cases are identifiable by the fact that the base line is always numbered 0.

**LAND CLASSIFICATION.**  
This is shown on the map by the blue letters. It is explained in the following township description and at length in chapter V.

**MAGNETIC DATA.**  
Dial compass readings are shown in blue figures. Eastward declinations are shown with a dot to the east and westward with a dot to west of the number. Dip needle readings are shown in black. All are positive except those preceded by the negative sign. All readings show deviation of needles from the normal reading of the instrument used. Normal readings are omitted from the map except at each quarter section corner. All abnormal readings are shown.

Traverses were made on lines indicated—usually the N-S section and quarter lines. Dip needle readings were taken each 50 paces, dial compass readings each 100 paces when sun permitted.

Magnetic lines are indicated by heavy black lines, solid where definite and dashed where doubtful.

**CAUTION:** Almost any kind of rock may be the cause of magnetic attraction. Do not fail to read the following description of this township, and also chapter IV., in which the magnetic attractions are discussed.

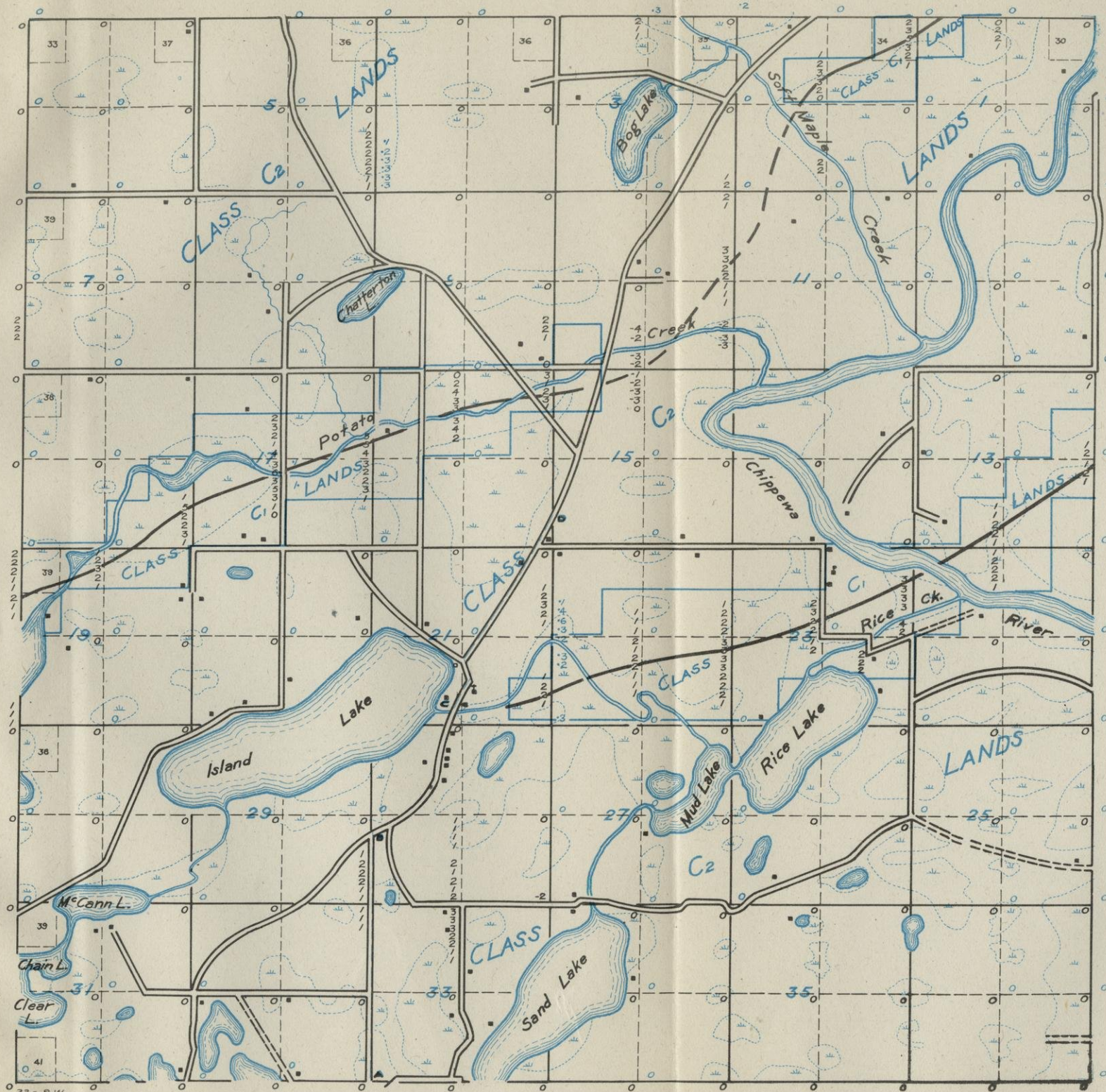

**PROFILES**

VERTICAL SCALE: 1 space = 20'  
HORIZONTAL SCALE: same as map

LOCAL DATUM

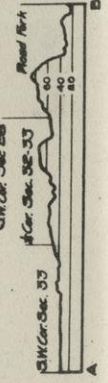
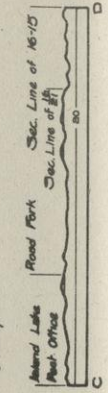



needle readings with a few deflections of the dial compass were obtained. Three fairly definite lines can be drawn, from section 13 to section 21, from the northeast corner of section 16 to the northwest corner of 19, and across sections 1 and 2. The line in section 1 is continuous to the northeast. It may also connect with the one in section 16 as indicated by the dashed line. These lines are approximately parallel and indicate the strike of the magnetic formations. While the cause of the attractions is not known it is quite certainly a sedimentary formation and not improbably an iron formation.

*Land Classification.*—The principles of land classification employed in this work are discussed in chapter V. All lands crossed by these more definite magnetic belts or lying in their immediate vicinity are classed as C1. Other lands in the township are placed in class C2, for lack of information upon which to base a more definite classification.

*Exploration.*—A reasonable amount of exploration in the magnetic areas seems warranted. A series of shallow holes to test ledge across and for some distance north and south of the more definite magnetic lines would show whether or not an iron formation is the cause and might lead to the discovery of ore. Much of the work done in exploration for iron ore is wasted because of failure to make intelligent use of the geologic and magnetic data to be obtained by a careful preliminary survey, and because the geologic information given by the drill is not properly used as a guide for further work. The value of careful scientific methods of exploration therefore cannot be too strongly emphasized. Before formulating plans for exploration the discussion of this subject in chapter VI should be carefully studied.

## TOWNSHIP 34 N., RANGE 7 W.

*Surface Features.*—Except near the Chippewa and Flambeau Rivers this township is quite level, but there are a few areas of rough, hummocky ground, as in the east side of section 17, along the west line of 17 and 20, and along the line between 28 and 29. Along the Chippewa River south of Bruce the topography is markedly rolling. Throughout its entire course in the township, the Flambeau River lies from 30 to 60 feet below the general level, and for one-half mile on each side the surface is rough. Sections 9, 10, 15, and 16 are exceptionally flat and generally very swampy. The railroad and road profiles on the accompanying map show the level nature of the country.

Roads are generally well graded and drained, and travel is seldom difficult except in the spring of the year. Practically all the timber has been removed and settlement is going on rapidly. Dairying and potato raising are the chief farm activities. One well improved farm in section 17 is shown in plate VIII. A pulp mill is located on the west side of Flambeau River in section 22.

*Glacial Geology.*—The greater part of the township is covered by a deposit of outwash, composed of sand and gravel with a few bowlders and some blue clay which is frequently found in digging wells. This clay probably represents lake stages in the deposition of the outwash. The outwash forms essentially a plain but is much pitted in places and considerably eroded along the Chippewa River, giving it a rough appearance. The east boundary of the outwash is a line drawn from the northeast corner of section 12 to the southwest corner of 21, thence south to the township line. The rest of the township is undulating ground moraine, which is composed of silt, sand, and bowlders. It is somewhat better drained than the outwash area and carries a different type of vegetation. Where crossed by the Flambeau River, it has been rather deeply cut by erosion.

The thickness of the drift in this township will vary from 30 feet to probably as much as 150 feet. Where the sandstone is exposed in section 24 the drift covering is very light, but elsewhere it appears to be much greater. Wells around Bruce are reported to be down to a depth of nearly 100 feet in sand and gravel without encountering ledge.

*General Geology.*—A single outcrop or group of outcrops was found in the N. W.  $\frac{1}{4}$  of section 24 on the south side of the Flambeau River. The rock is a very coarse, poorly cemented sandstone which undoubtedly belongs to the Cambrian. This probably underlies the hill for some distance back from the river, but it is believed to be merely an outlier, and not connected with the main sandstone formation to the west. There is no definite information on the character of the pre-Cambrian formations which underlie this township. About three miles west there is an outcrop of chert and iron ore, which strikes in a general direction toward section 6, and suggests the probability that at least some Huronian sediments underlie this township.

*Magnetic Observations.*—A general discussion of magnetic observations and their significance is given in chapter IV. This should be carefully studied before attempting to interpret the readings shown on the map. Irregular and disconnected dip needle readings were obtained over a considerable part of this township, but they do not connect up to form well defined magnetic lines. A poorly defined line in section 31 extends into the townships to the west and southwest. The irregular belt running north and south through the middle of the township suggests a mildly magnetic formation bowed to the west in sections 16 and 21 and swinging back to the southeast and turning again to the west in the northern part of T. 33-7 W.

*Land Classification.*—The principles of land classification employed in this work are discussed in chapter V. Because of the lack of information definite classification of the lands in this township is not possible and all are placed in class C2.

*Exploration.*—Exploration of any particular tracts of land in this township cannot be recommended until further information regarding the character of underlying formations is obtained.

It is not at all improbable that iron formation may be found although the results of this survey showed no indication of its presence. The iron bearing rocks found in section 10, T. 34-8 W. may extend into the northwestern part of this township and this at the present time appears to be one of the most favorable prospects. A small amount of work in the magnetic areas might show the presence of iron formation. Much of the work done in exploration for iron ore is wasted because of failure to make intelligent use of the geological

and magnetic data to be obtained by a careful preliminary survey and because the geologic information given by the drill is not properly used as a guide for further work. The value of careful scientific methods of exploration therefore cannot be too strongly emphasized. If exploration is contemplated in this township the discussion of this subject in chapter VI should be carefully studied.

TOWN 34 N., R. 7W.

Survey Made in June, 1914

Under the Direction of  
W. O. HOTCHKISS, State Geologist  
AND  
E. F. BEAN and O. W. WHEELWRIGHT,  
in charge of Field Parties

BY  
O. W. WHEELWRIGHT, Chief of Party  
GEO. NISHIHARA, Asst. Geologist  
O. W. POTTER, Asst. Geologist  
HOWARD QUINLAN, Asst. Geologist

**SYMBOLS AND ABBREVIATIONS.**  
The symbols and abbreviations used on this map are explained in Chapter II.

**TOWN AND RANGE LINES.**  
In constructing this map the south line of the township was laid off as a true east west line. The other boundary lines were then laid off with the lengths shown on the Land Survey plat. Some of the maps are therefore incorrect in shape but this is necessary because definite facts are lacking. The acreage of part of the lots in the north and west tier of sections is shown to give a check on the distances in these sections.

**LOCATIONS.**  
All locations are based on pacing traverses from government land corners. In many cases these were not found and it was necessary to continue the traverse several miles without a check. Locations of certain features may therefore be somewhat wrong. In such cases the feature sought may best be located by its relation to a stream, swamp, lake, or other feature shown on the map.

**PROFILES.**  
The locations of the profiles are shown on the map by dashed blue lines with black letters at the ends. Railroad profiles were furnished by the companies and show elevations of the ground rather than track in most cases; others are from road surveys by the State Highway Commission; most of them are hand level lines made by this Survey. Wherever possible the elevations above sea level are given. These elevations vary from 1050 to 1770 feet. A local datum plane was necessarily assumed in some cases. These cases are identifiable by the fact that the base line is always numbered 0.

**LAND CLASSIFICATION.**  
This is shown on the map by the blue letters. It is explained in the following township description and at length in chapter V.

**MAGNETIC DATA.**  
Dial compass readings are shown in blue figures. Eastward declinations are shown with a dot to the east and westward with a dot to west of the number. Dip needle readings are shown in black. All are positive except those preceded by the negative sign. All readings show deviation of needles from the normal reading of the instrument used. Normal readings are omitted from the map except at each quarter section corner. All abnormal readings are shown.

Traverses were made on lines indicated—usually the N-S section and quarter lines. Dip needle readings were taken each 50 paces, dial compass readings each 100 paces when sun permitted.

Magnetic lines are indicated by heavy black lines, solid where definite and dashed where doubtful.

**CAUTION:** Almost any kind of rock may be the cause of magnetic attraction. Do not fail to read the following description of this township, and also chapter IV., in which the magnetic attractions are discussed.

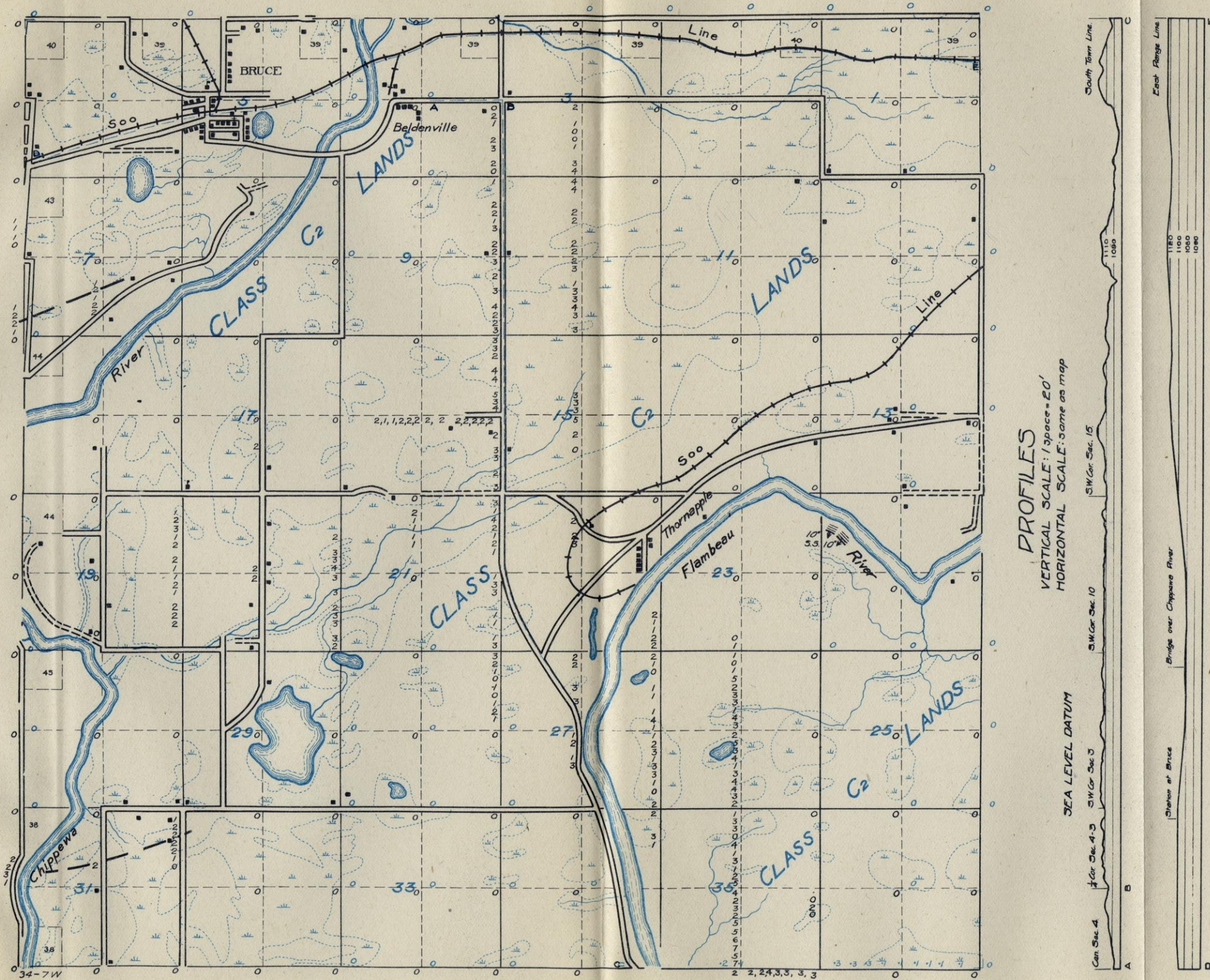

**PROFILES**  
VERTICAL SCALE: 1 space = 20'  
HORIZONTAL SCALE: same as map

SEA LEVEL DATUM

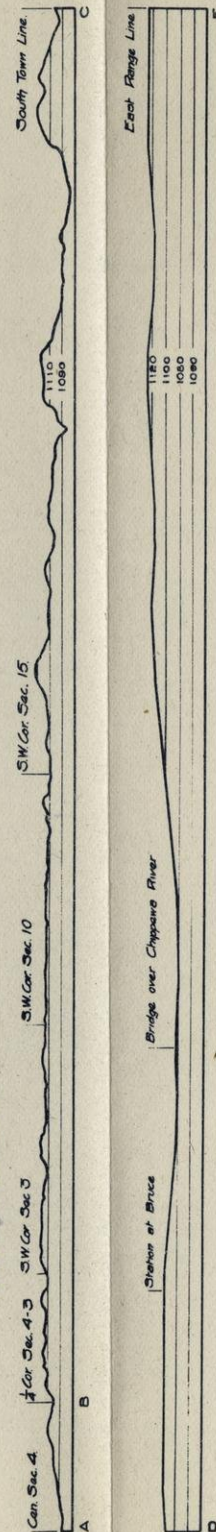

## TOWNSHIP 34 N., RANGE 8 W.

*Surface Features.*—The eastern part of this township, with the exception of parts of sections 13, 14, 23 and 24 is gently undulating to flat. The central portion is flat and the western part is higher and gently undulating. The highest part is in section 6, where glacial drift probably mantles the Barron quartzite. The northeastern part drains northeast to the Chippewa river through Hay creek. The remainder of the township drains southeast to the Chippewa river through Soft Maple creek.

Profile A-B shows the descent from the higher western portion to the lower level area to the east. Profile C-D shows that the western area is about 100 feet higher than the plain to the east.

The main traveled road, parallel to the railroad, is well graded and kept in good repair. Nearly all the roads of the township are fairly good. Very little good timber is left and agriculture is developing rapidly. A creamery was opened in Weyerhauser in 1914, and dairying should prove an important industry.

*Glacial Drift.*—Gently undulating ground moraine is found in sections 31, 4, 5, and 8. Terminal moraine occurs in the western part of the township and in sections 13, 14, 23, and 24, where the topography varies from very roughly undulating to gently undulating. The remainder of the township is a flat to gently undulating outwash plain with dissection near stream courses. The glacial deposits are largely sand, silt and boulders in the ground moraine; silt, sand and gravel with boulders in the terminal moraine; sand, some gravel, and a few boulders in the outwash.

The thickness of the drift in this township varies greatly. A rock exposure and wells in the central part show thin drift, and in a well in the N. W.  $\frac{1}{4}$  of the N. E.  $\frac{1}{4}$  of section 3, ledge was not reached at a depth of 120 feet. Another well in the N. W.  $\frac{1}{4}$  of the N. E.  $\frac{1}{4}$  of section 36, shows 100 feet of drift. It seems quite certain that the greater elevation of the western portion of this township is largely due to the fact that in preglacial time this was a highland with a valley to the east, since the well records show a somewhat thinner covering of drift over the western portion than is found over the eastern part.

*General Geology.*—The only outcrop found in this township is located along the railroad in the S. W.  $\frac{1}{4}$  of section 10. The rock is mainly a massive, somewhat pyritic chert, which in places carries

iron oxide, both in irregular bands and in a disseminated form. Most of the iron is hematite with probably some magnetite. In some places limonite occurs as a coating over the rock. Several test pits have been sunk into this formation in a search for iron ore. Some of the material in the most westerly pits has a slaty appearance probably because of being on a shear zone developed during folding. This formation is magnetic, showing abnormal dips of  $6^{\circ}$  to  $8^{\circ}$ , but the area of attraction is very limited in extent as determined by the dip needle.

The formation is very badly folded and owing to its brittle character, much brecciated. The structure is not certain, but this exposure appears to be at the crest of an anticline. The rock strikes about N.  $70^{\circ}$  E., and dips at greatly varying angles to the north, where exposed on the north side of the railroad track, and slightly to the south where exposed on the south side of the track. These determinations of south dip are uncertain, however. While this rock differs considerably from the usual Lake Superior iron formations it was apparently deposited under conditions not greatly dissimilar and it is not improbable that better iron formation may be found nearby.

A well near the center of section 9 penetrated a very schistose acid igneous rock containing considerable pyrite, which is very much like the porphyry found in T. 33-6W and in the southwestern part of T.36-7W., and is possibly of the same age.

Ten wells which penetrated sandstone are indicated on the map. The rock brought from these wells is a very soft friable sandstone which undoubtedly belongs to the Cambrian. The extent to which this formation underlies this township is uncertain but its occurrence is apparently quite general. Beneath this sandstone, which is believed to be thin, there are rocks of pre-Cambrian age, of whose character but little is known. That there are both igneous and sedimentary rocks present is shown by the exposure in section 10 and the well in section 16.

*Magnetic Observations.*—A general discussion of magnetic observations and their significance is given in Chapter IV. Mild abnormal readings of both dip and dial compasses were obtained generally over this township. The belts or areas are not distinct and definite lines connecting the maximum readings cannot be drawn except in section 36. The dashed lines drawn elsewhere are placed on the map because they are thought to indicate general lines of structure. As mentioned above, the chert and iron ore is magnetic where exposed, but this is only a very small area. The attraction is section 18 may

TOWN 34 N., R. 8W.

Survey Made in June, 1914

Under the Direction of  
W. O. HOTCHKISS, State Geologist  
AND  
E. F. BEAN and O. W. WHEELWRIGHT,  
in charge of Field Parties  
BY  
LOUIS ROARK, Chief of Party  
J. P. GOLDSBERRY, Asst. Geologist  
GEO. BELCHIE, Asst. Geologist

**SYMBOLS AND ABBREVIATIONS.**  
The symbols and abbreviations used on this map are explained in Chapter II.

**TOWN AND RANGE LINES.**  
In constructing this map the south line of the township was laid off as a true east west line. The other boundary lines were then laid off with the lengths shown on the Land Survey plat. Some of the maps are therefore incorrect in shape but this is necessary because definite facts are lacking. The acreage of part of the lots in the north and west tier of sections is shown to give a check on the distances in these sections.

**LOCATIONS.**  
All locations are based on pacing traverses from government land corners. In many cases these were not found and it was necessary to continue the traverse several miles without a check. Locations of certain features may therefore be somewhat wrong. In such cases the feature sought may best be located by its relation to a stream, swamp, lake, or other feature shown on the map.

**PROFILES.**  
The locations of the profiles are shown on the map by dashed blue lines with black letters at the ends. Railroad profiles were furnished by the companies and show elevations of the ground rather than track in most cases; others are from road surveys by the State Highway Commission; most of them are hand level lines made by this Survey. Wherever possible the elevations above sea level are given. These elevations vary from 1050 to 1770 feet. A local datum plane was necessarily assumed in some cases. These cases are identifiable by the fact that the base line is always numbered 0.

**LAND CLASSIFICATION.**  
This is shown on the map by the blue letters. It is explained in the following township description and at length in chapter V.

**MAGNETIC DATA.**  
Dial compass readings are shown in blue figures. Eastward declinations are shown with a dot to the east and westward with a dot to west of the number. Dip needle readings are shown in black. All are positive except those preceded by the negative sign. All readings show deviation of needles from the normal reading of the instrument used. Normal readings are omitted from the map except at each quarter section corner. All abnormal readings are shown.

Traverses were made on lines indicated—usually the N-S section and quarter lines. Dip needle readings were taken each 50 paces, dial compass readings each 100 paces when sun permitted.

Magnetic lines are indicated by heavy black lines, solid where definite and dashed where doubtful.

**CAUTION:** Almost any kind of rock may be the cause of magnetic attraction. Do not fail to read the following description of this township, and also chapter IV., in which the magnetic attractions are discussed.

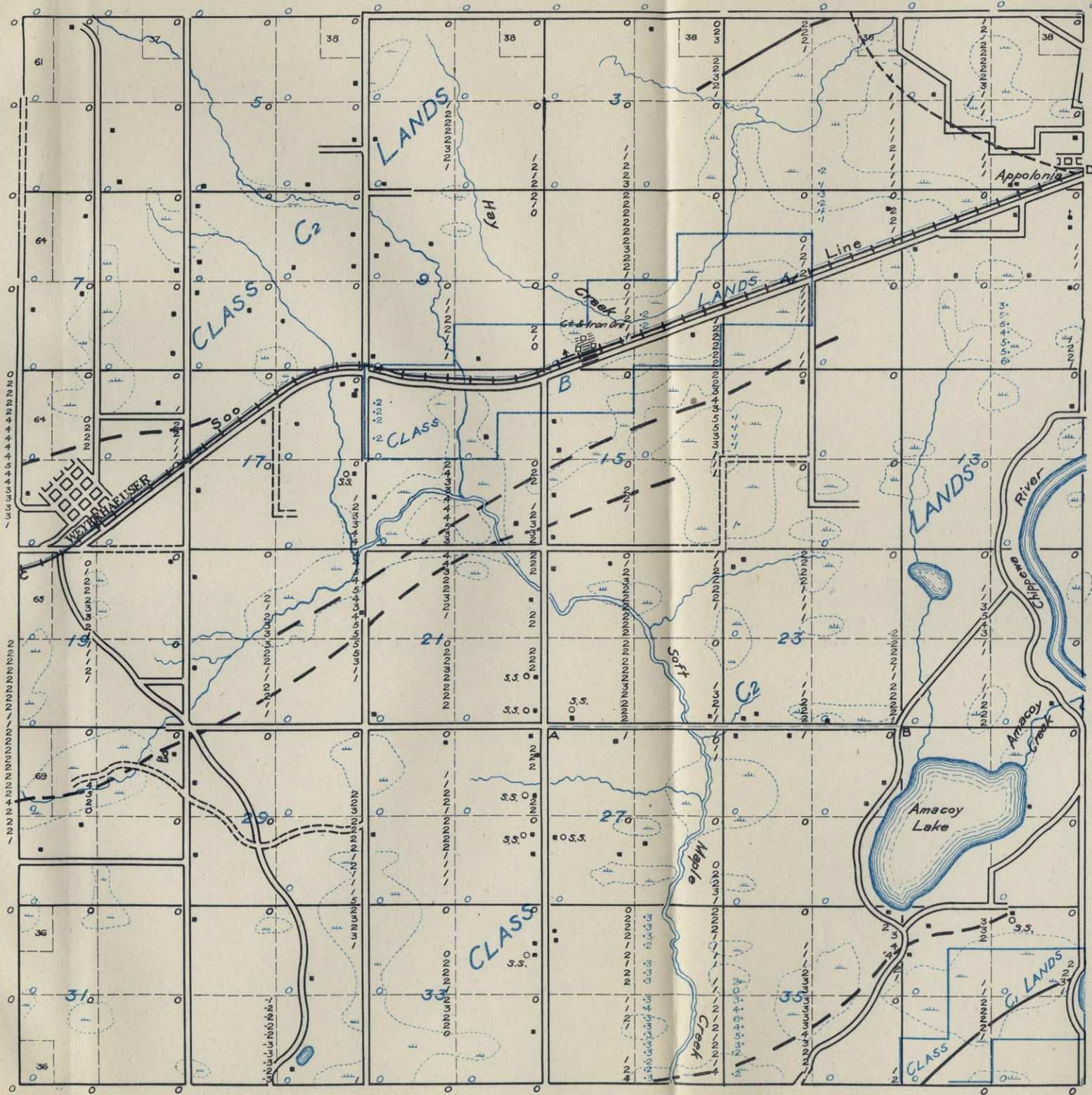

**PROFILE**  
VERTICAL SCALE: 1 space = 20'  
HORIZONTAL SCALE: same as map

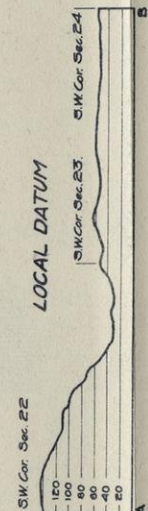



mark the extension of this bed. That in section 36 continues in the township to the south and as suggested in the report on that township may be part of a long continuous magnetic line. The line in section 2 can be traced a short distance in the township to the north. The decided irregularity of the attractions elsewhere in the township makes it appear doubtful whether they represent iron formation.

*Land Classification.*—For a thorough understanding of the principles of land classification employed in this work the reader is referred to Chapter V. Lands at and directly along the strike of the outcrop in section 10 are classed as B lands. Where exposed this rock does not offer particular promise for iron ore, but if followed up it might develop into a softer formation which would prove productive. Lands crossed by the line in section 36 are placed in class C1. All others are classed as C2.

*Exploration.*—A reasonable amount of exploration planned for the purpose of determining the possibility of ore along the strike of the chert and iron ore formation in section 10 seems warranted. Undoubtedly the exposed part of this formation is the hardest part and it appears quite possible that under the glacial drift a productive formation might be found. Shallow drill holes or test pits if the depth of surface would permit, should be sunk a short distance northeast and southwest of this exposure, and placed in a line approximately normal to the direction of the railroad track which runs nearly parallel to the line of strike in the formation. There is little to encourage exploration elsewhere but the magnetic line in section 36 may indicate the presence of iron formation. Much of the work done in exploration for iron ore is wasted because of failure to make intelligent use of the geologic and magnetic data to be obtained by a careful preliminary survey, and because the geologic information given by the drill is not properly used as a guide for further work. The value of careful scientific methods of exploration therefore cannot be too strongly emphasized. If exploration is contemplated in this township the discussion of this subject in chapter VI should be carefully studied.

## TOWNSHIP 34 N., RANGE 9 W.

*Surface Features.*—The northern part of this township is high and rough. South of the railroad in sections 14, 15, 22, 27, 28, 33, 34, and 35 is a belt of hummocky topography. Along the west range line south of the railroad the topography is gently to roughly undulating. The remainder south of the railroad is flat to rolling. The accompanying profiles show elevations varying from 1,200 feet above sea level at the southeast corner of sections 13, to 1,472 feet at the northwest corner of section 4. Profile E-D shows that the northwest corner of section 4 is 160 feet higher than the southwest corner. The greater elevation of the northern part of the township is due to the underlying Barron quartzite.

The main traveled road runs east-west through the center of the township. This is well graded. The roads leading north from this are few in number and poorly graded. The roads leading south are somewhat better. Nearly all of the timber has been cut.

*Glacial Deposits.*—In the north part of the township is a terminal moraine belt which lies along the southern edge of the quartzite. Along the west range line south of the railroad lies a gently undulating terminal moraine. South of the railroad in sections 14, 15, 22, 27, 28, 33, 34, and 35 is an area of roughly undulating terminal moraine characterized by an abundance of gravel and boulders. The remainder of the township is rolling ground moraine with small areas of level outwash. The glacial deposits are largely sand, gravel and silt in the ground moraine; sand, gravel, silt and numerous boulders in the terminal moraine.

The thickness of the drift varies from a thin veneer over the quartzite in the northern part to a thickness of at least 90 feet in section 32. The average thickness over the southeastern part of the township is probably not over 60 feet. In the central and western parts the drift cover is probably somewhat heavier.

*General Geology.*—No exposures of ledge are found in this township. In the south half of section 6 talus slopes of quartzite are found and it is believed that approximately the north half of the north row of sections is underlain by the Barron quartzite which occurs commonly to the north and west. Well records and outcrops in the adjoining townships indicate that the remainder of this township, with the possible exception of the northeast quarter, is underlain by the Cambrian sandstone. The older rocks underlying

TOWN 34 N., R. 9 W.

Survey Made in June, 1914

Under the Direction of  
W. O. HOTCHKISS, State Geologist  
AND  
E. F. BEAN and O. W. WHEELWRIGHT,  
in charge of Field Parties

BY  
W. I. ROBINSON, Chief of Party  
S. M. WILLIS, Asst. Geologist  
G. M. SCHWARTZ, Asst. Geologist

**SYMBOLS AND ABBREVIATIONS.**  
The symbols and abbreviations used on this map are explained in Chapter II.

**TOWN AND RANGE LINES.**  
In constructing this map the south line of the township was laid off as a true east west line. The other boundary lines were then laid off with the lengths shown on the Land Survey plat. Some of the maps are therefore incorrect in shape but this is necessary because definite facts are lacking. The acreage of part of the lots in the north and west tier of sections is shown to give a check on the distances in these sections.

**LOCATIONS.**  
All locations are based on pacing traverses from government land corners. In many cases these were not found and it was necessary to continue the traverse several miles without a check. Locations of certain features may therefore be somewhat wrong. In such cases the feature sought may best be located by its relation to a stream, swamp, lake, or other feature shown on the map.

**PROFILES.**  
The locations of the profiles are shown on the map by dashed blue lines with black letters at the ends. Railroad profiles were furnished by the companies and show elevations of the ground rather than track in most cases; others are from road surveys by the State Highway Commission; most of them are hand level lines made by this Survey. Wherever possible the elevations above sea level are given. These elevations vary from 1050 to 1770 feet. A local datum plane was necessarily assumed in some cases. These cases are identifiable by the fact that the base line is always numbered 0.

**LAND CLASSIFICATION.**  
This is shown on the map by the blue letters. It is explained in the following township description and at length in chapter V.

**MAGNETIC DATA.**  
Dial compass readings are shown in blue figures. Eastward declinations are shown with a dot to the east and westward with a dot to west of the number. Dip needle readings are shown in black. All are positive except those preceded by the negative sign. All readings show deviation of needles from the normal reading of the instrument used. Normal readings are omitted from the map except at each quarter section corner. All abnormal readings are shown.

Traverses were made on lines indicated—usually the N-S section and quarter lines. Dip needle readings were taken each 50 paces, dial compass readings each 100 paces when sun permitted.

Magnetic lines are indicated by heavy black lines, solid where definite and dashed where doubtful.

**CAUTION:** Almost any kind of rock may be the cause of magnetic attraction. Do not fail to read the following description of this township, and also chapter IV., in which the magnetic attractions are discussed.

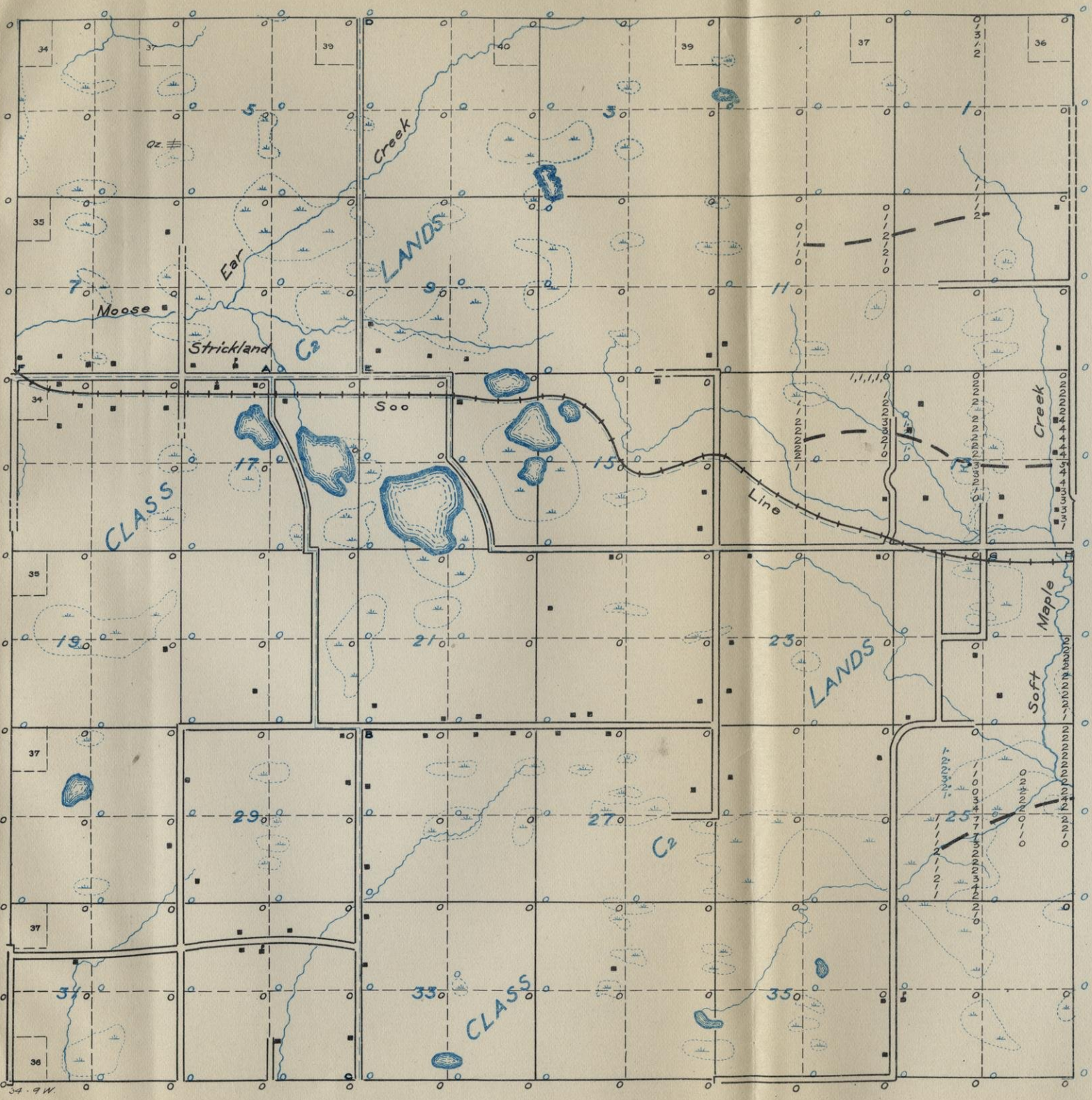

PROFILES  
VERTICAL SCALE: 1 space = 20'  
HORIZONTAL SCALE: same as map

SEA LEVEL DATUM

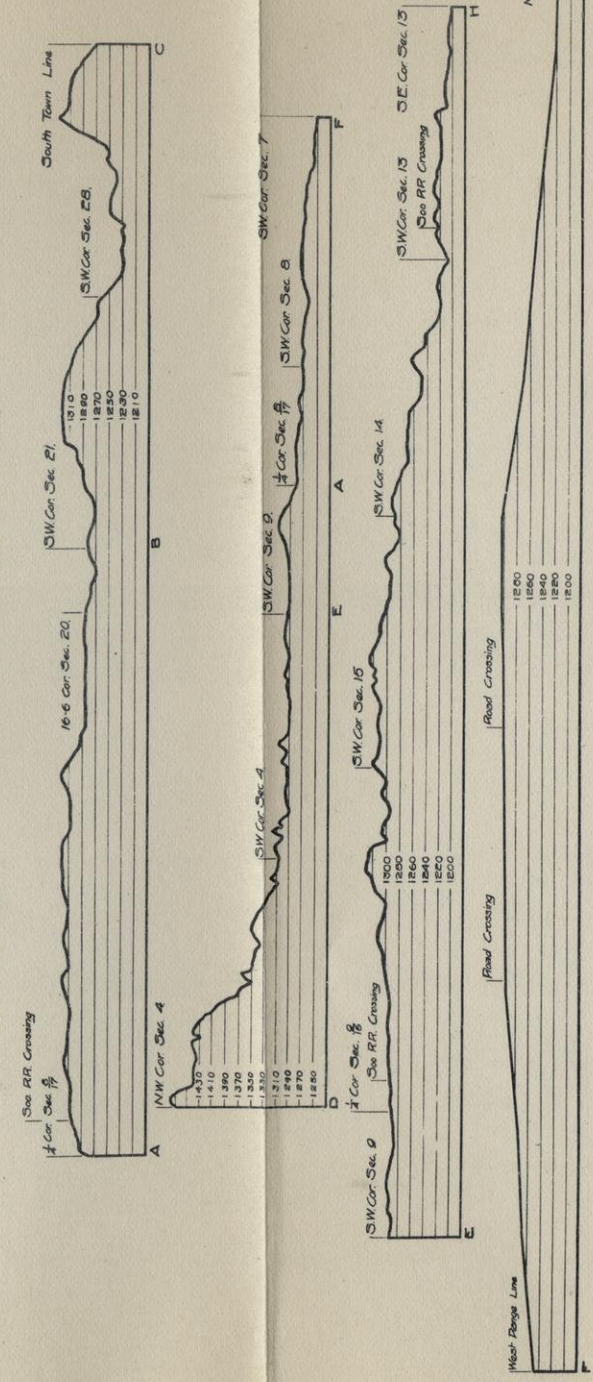

are believed from information obtained to the east, to be both igneous and sedimentary in origin, in which case iron formation may be present.

*Magnetic Observations.*—A general discussion of magnetic observations and their significance is given in chapter IV. Erratic readings of the dip needle and a few mild deflections of the dial compass were obtained in the eastern part of the township. These attractions cover broad areas and the lines are not very definite but with the exception of the line in sections 11 and 12 are continuations of attractions in the township to the east. The apparent lack of definite maxima may be due in part to burial beneath a considerable thickness of sandstone. The lines probably indicate the presence of sedimentary rocks in the pre-Cambrian and these may be iron formation.

*Land Classification.*—The general principles of land classification employed in this work are discussed in this work in chapter V. All lands in this township are placed in class C2. They are probably underlain by Huronian rocks in which iron formations may occur but there is no positive evidence of such occurrence. The irregular character of the magnetic attractions does not warrant giving these lands any higher classification.

Neither the sandstone nor quartzite is believed to be thick enough to seriously interfere with the prospects of finding iron formation in the older rocks underneath.

*Exploration.*—As a result of the information obtained by this survey, exploration of particular areas in this township is not especially recommended. Undoubtedly the magnetic areas offer the most promise at the present time and any contemplated work should be started where the attractions are found. If work in the magnetic areas to the east should show the attraction to result from the presence of iron formation the magnetic areas in this township would be more highly recommended. Much of the work done in exploration for iron ore is wasted because of failure to make intelligent use of the geologic and magnetic data to be obtained by a careful preliminary survey, and because the geologic information given by the drill is not properly used as a guide for further work. The value of careful scientific methods of exploration therefore cannot be too strongly emphasized. If exploration is contemplated in this township the discussion of this subject in chapter VI should be carefully studied.

## TOWNSHIP 34 N., RANGE 10 W.

*Surface Features.*—The greater part of this township is flat to gently undulating. In the extreme north is the quartzite highland. In the east central part is an area of gently undulating topography. In the southwest Pokegama Creek occupies a valley through which a much larger stream once flowed. The accompanying profiles show a relief of 130 feet in section 16 and of 120 feet between Canton and Lehigh.

The roads in the well settled west and southwest parts of this township are good. Agriculture is the leading industry. The good farm buildings and fine herds of dairy cows in the older settled portions of the township speak well for the fertility of the soil and the future of this township.

*Glacial Drift.*—South of the quartzite, in the northeastern and northwestern parts of the township, and in the east central part are areas of terminal moraine. In the west there is a strip of outwash along Pokegama Creek. It seems probable that this is a pre-glacial valley as no wells reach rock here. The remainder of the township is very gently undulating ground moraine. The glacial deposits are sand, silt, gravel and boulders in the terminal; sand, silt, and a few boulders in the ground moraine; and silt and sand in the outwash.

The glacial drift is very thin in the northern part of the area and in sections 15, 20, 27, 28, 29, and 30, where ledge occurs. Drift is somewhat heavier in the east central part, probably averaging 60 feet in thickness. In the valley of Pokegama Creek wells are shallow and do not reach ledge. It seems likely that the drift cover here is considerably thicker than elsewhere in the township.

*General Geology.*—In the northern tier of sections outcrops and talus slopes of the Barron quartzite are found at frequent intervals and it is believed that most of these sections are underlain by this formation. Where noted in position the rock has a northeast strike and dips northwest at an angle of about 10°. As indicated by talus slopes, outliers of this same formation occur near the E.  $\frac{1}{4}$  S. of 21, and near the S.  $\frac{1}{4}$  S. of 15.

A soft, friable, white to yellow, fossiliferous sandstone is found outcropping in a railroad cut at the center of section 8; in the N. E.  $\frac{1}{4}$  of the S. W.  $\frac{1}{4}$  of 20; along the wagon road north of the S. W. corner of 27, and in a road cut on the east and west road 250 paces east of the west line of 33. This rock has also been encountered in nu-

TOWN 34 N., R. 10W.

Survey Made in August, 1914

Under the Direction of

W. O. HOTCHKISS, State Geologist

AND

E. F. BEAN and O. W. WHEELWRIGHT,  
in charge of Field Parties

BY

W. I. ROBINSON, Chief of Party

S. M. WILLIS, Asst. Geologist

H. N. EIDEMILLER, Asst. Geologist

SYMBOLS AND ABBREVIATIONS.

The symbols and abbreviations used on this map are explained in Chapter II.

TOWN AND RANGE LINES.

In constructing this map the south line of the township was laid off as a true east west line. The other boundary lines were then laid off with the lengths shown on the Land Survey plat. Some of the maps are therefore incorrect in shape but this is necessary because definite facts are lacking. The acreage of part of the lots in the north and west tier of sections is shown to give a check on the distances in these sections.

LOCATIONS.

All locations are based on pacing traverses from government land corners. In many cases these were not found and it was necessary to continue the traverse several miles without a check. Locations of certain features may therefore be somewhat wrong. In such cases the feature sought may best be located by its relation to a stream, swamp, lake, or other feature shown on the map.

PROFILES.

The locations of the profiles are shown on the map by dashed blue lines with black letters at the ends. Railroad profiles were furnished by the companies and show elevations of the ground rather than track in most cases; others are from road surveys by the State Highway Commission; most of them are hand level lines made by this Survey. Wherever possible the elevations above sea level are given. These elevations vary from 1050 to 1770 feet. A local datum plane was necessarily assumed in some cases. These cases are identifiable by the fact that the base line is always numbered 0.

LAND CLASSIFICATION.

This is shown on the map by the blue letters. It is explained in the following township description and at length in chapter V.

MAGNETIC DATA.

Dial compass readings are shown in blue figures. Eastward declinations are shown with a dot to the east and westward with a dot to the west of the number. Dip needle readings are shown in black. All are positive except those preceded by the negative sign. All readings show deviation of needles from the normal reading of the instrument used. Normal readings are omitted from the map except at each quarter section corner. All abnormal readings are shown.

Traverses were made on lines indicated—usually the N-S section and quarter lines. Dip needle readings were taken each 50 paces, dial compass readings each 100 paces when sun permitted.

Magnetic lines are indicated by heavy black lines, solid where definite and dashed where doubtful.

CAUTION: Almost any kind of rock may be the cause of magnetic attraction. Do not fail to read the following description of this township, and also chapter IV., in which the magnetic attractions are discussed.

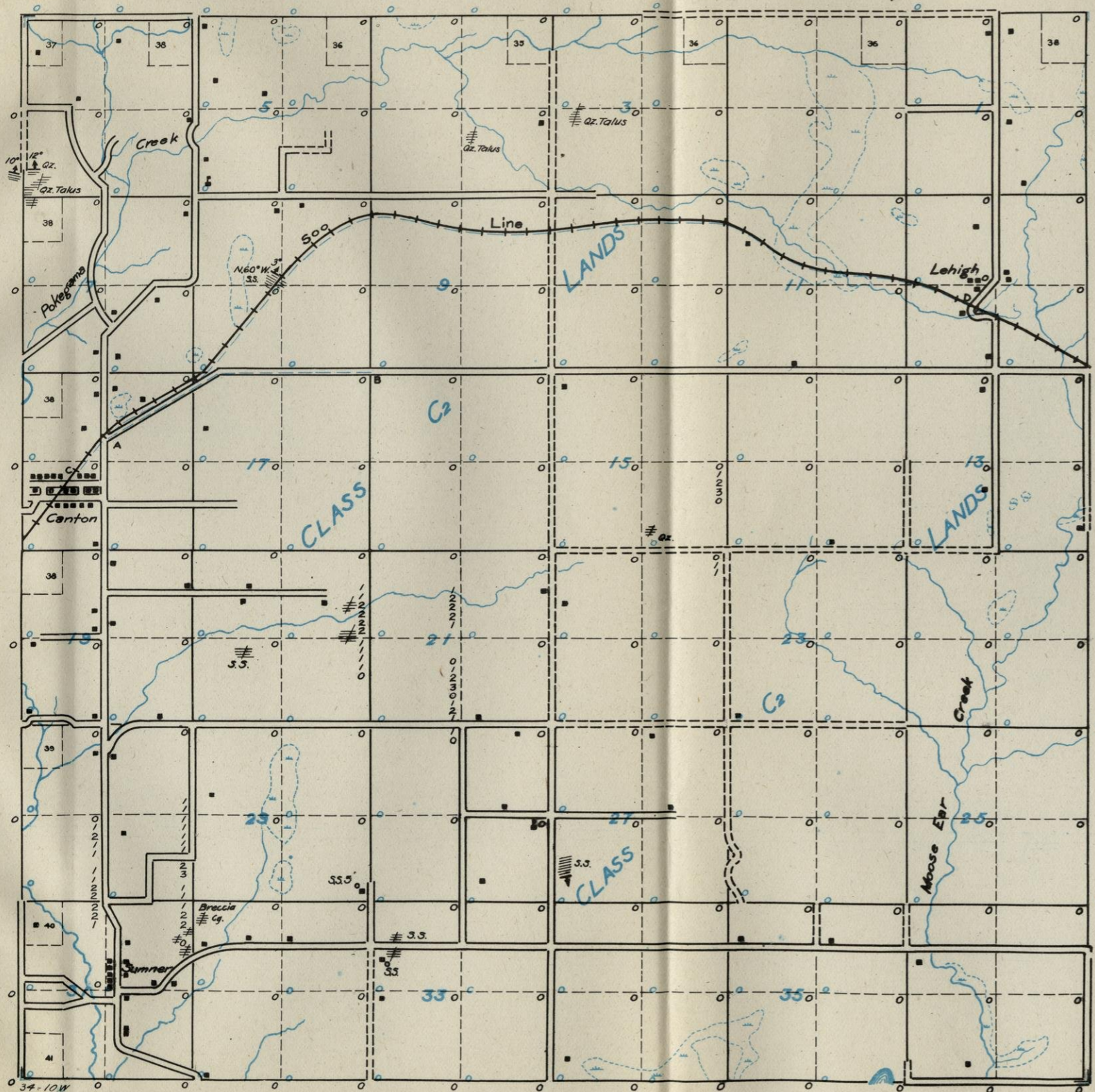

PROFILE

VERTICAL SCALE: 1 space = 20'  
HORIZONTAL SCALE: same as map

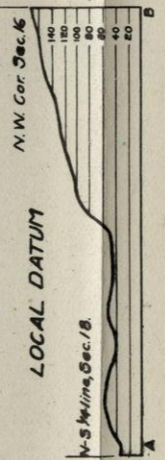

SEA LEVEL DATUM

Station at Lehigh

Station at Center

merous wells over the township. It is undoubtedly of Cambrian age.

Along the east line of 31 about midway between the N. E. corner and the E.  $\frac{1}{4}$  S. is an outcrop of quartzite breccia. This rock is composed of large blocks of light red quartzite identical with the Barron formation, which are very little rounded and show no special arrangement in the formation. They are cemented with a matrix of lighter colored quartzite which is somewhat less indurated than the enclosed blocks. In a few instances masses of quartzite several feet in diameter were observed, which suggested the original ledge, but these are believed to be merely larger blocks than those which make up the main part of the formation. This breccia is believed to have originated in the breaking down of a cliff of Barron quartzite and may represent either a second quartzite series or may be of Cambrian age. It seems quite certain that all of that part of the township not underlain by the quartzite will be found to have a thin covering of the Cambrian sandstone.

*Magnetic Observations.*—A general discussion of magnetic observations and their significance is given in chapter IV. A few erratic dip needle readings were encountered in sections 15, 21, 30, and 31, but these are not of such character that they can be interpreted as indicating the presence of an iron formation.

*Land Classification.*—The principles of land classification employed in this work are discussed in Chapter V. In classifying the lands in this township the Barron quartzite and Cambrian sandstone are left out of consideration for the reason that they are not considered to be of very great thickness. A series of older rocks will undoubtedly be found underneath, but of their character we have no knowledge and consequently all lands are placed in class C2.

*Exploration.*—With our present knowledge of the geology of this township, exploration is not recommended. Deeper wells may in the future penetrate the pre-Cambrian rocks and serve as a clue for exploration.

## TOWNSHIP 35 N., RANGE 6 W.

*Surface Features.*—The greatest portion of this township has a very gently undulating surface. In the southern part there are a few gravel ridges rising 15 or 20 feet above the general level. The accompanying profile serves to emphasize the fact that this is an extremely level township. Flambeau River flows across the southeast corner, Thornapple river enters the township in section 3 and flows out near the west  $\frac{1}{4}$  corner of section 19, and Little Thornapple creek drains the northwestern part of the area.

The roads in the southern part of the area are quite good. Except for small tracts of hardwood in the northwestern and eastern parts of the township the timber has all been cut. Farming is developing in the central, north central, and southern portions.

*Glacial Drift.*—In the southern part of the township there are a few low terminal moraine ridges composed largely of sand and gravel but the greater part of the area is gently undulating ground moraine, with a large proportion of swamp. In sections 25 and 26 there are well defined terraces along the Flambeau river. The glacial deposits are sand and gravel in the terminal belts; silt, sand and boulders in the ground moraine.

The thickness of the drift is not definitely known. As there are rock outcrops in section 17 and the topography is very level, it seems probable that the covering of drift is thin except along Flambeau river.

*General Geology.*—Two small outcrops of diorite occur along the Thornapple river near the railroad bridge in section 17. No other exposures or borings in the underlying rock were found, and there is very little evidence for mapping the geology of the township. The results of the magnetic work in this and the adjoining townships indicate that the northwestern quarter is probably in an area of Huronian rocks and the remainder of the township in an area underlain principally by igneous rocks.

*Magnetic Observations.*—Magnetic observations and their significance are discussed in Chapter IV. Strong magnetic attraction was found at the southeast corner of section 4 where abnormal dip readings of  $32^\circ$  and dial deflections of  $17^\circ$  E. were found. Northeast and southwest from here irregular attractions were obtained but they do not connect to form a definite line. The character of these attractions is not such as to lead one to believe that they are caused



**TOWN 35 N., R. 6 W.**

Survey Made in September, 1914

Under the Direction of

**W. O. HOTCHKISS, State Geologist**

AND

**E. F. BEAN and O. W. WHEELWRIGHT,**  
in charge of Field Parties

BY

**W. I. ROBINSON, Chief of Party**

**S. M. WILLIS, Asst. Geologist**

**H. N. EIDEMILLER, Asst. Geologist**

**SYMBOLS AND ABBREVIATIONS.**

The symbols and abbreviations used on this map are explained in Chapter II.

**TOWN AND RANGE LINES.**

In constructing this map the south line of the township was laid off as a true east west line. The other boundary lines were then laid off with the lengths shown on the Land Survey plat. Some of the maps are therefore incorrect in shape but this is necessary because definite facts are lacking. The acreage of part of the lots in the north and west tier of sections is shown to give a check on the distances in these sections.

**LOCATIONS.**

All locations are based on pacing traverses from government land corners. In many cases these were not found and it was necessary to continue the traverse several miles without a check. Locations of certain features may therefore be somewhat wrong. In such cases the feature sought may best be located by its relation to a stream, swamp, lake, or other feature shown on the map.

**PROFILES.**

The locations of the profiles are shown on the map by dashed blue lines with black letters at the ends. Railroad profiles were furnished by the companies and show elevations of the ground rather than track in most cases; others are from road surveys by the State Highway Commission; most of them are hand level lines made by this Survey. Wherever possible the elevations above sea level are given. These elevations vary from 1050 to 1770 feet. A local datum plane was necessarily assumed in some cases. These cases are identifiable by the fact that the base line is always numbered 0.

**LAND CLASSIFICATION.**

This is shown on the map by the blue letters. It is explained in the following township description and at length in chapter V.

**MAGNETIC DATA.**

Dial compass readings are shown in blue figures. Eastward declinations are shown with a dot to the east and westward with a dot to west of the number. Dip needle readings are shown in black. All are positive except those preceded by the negative sign. All readings show deviation of needles from the normal reading of the instrument used. Normal readings are omitted from the map except at each quarter section corner. All abnormal readings are shown.

Traverses were made on lines indicated—usually the N-S section and quarter lines. Dip needle readings were taken each 50 paces, dial compass readings each 100 paces when sun permitted.

Magnetic lines are indicated by heavy black lines, solid where definite and dashed where doubtful.

**CAUTION:** Almost any kind of rock may be the cause of magnetic attraction. Do not fail to read the following description of this township, and also chapter IV., in which the magnetic attractions are discussed.

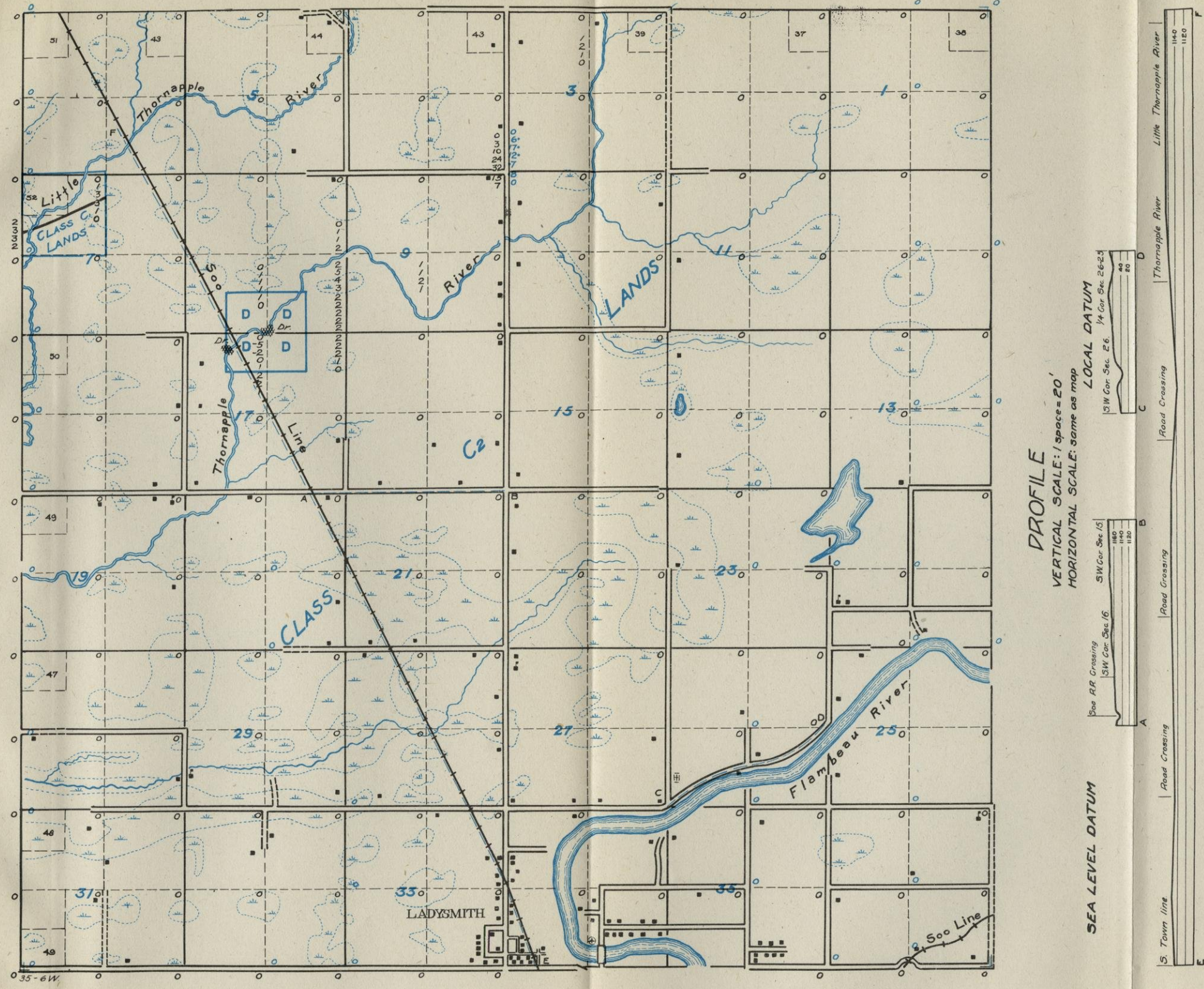

**PROFILE**

VERTICAL SCALE: 1 space = 20'  
HORIZONTAL SCALE: same as map

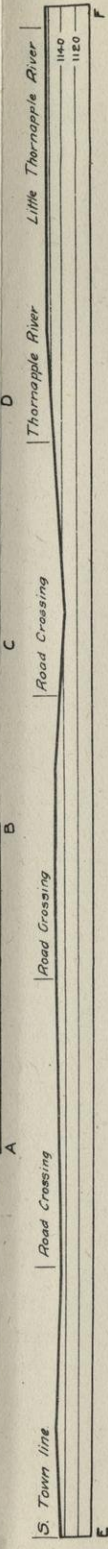
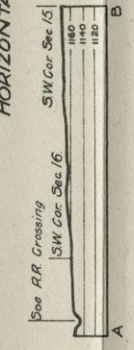
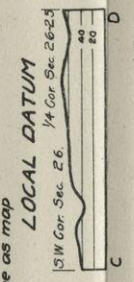

by iron formation. They may be caused by a magnetic greenstone or be the result of intrusion of a greenstone into a sedimentary formation. In the northwest corner of section 7 is a better defined line extending into the township to the west where it continues for more than a mile.

*Land Classification.*—The principles of land classification employed in this work are discussed in Chapter V. Lands upon which the greenstone is found outcropping are classed as D lands. The N. W.  $\frac{1}{4}$  of section 7 is classed as C1 because of the fairly well defined magnetic line. All others are placed in class C2. The presence of granite over the greater part of the township is not sufficiently certain to warrant a D classification for those lands.

*Exploration.*—In the light of present information exploration in this township is not especially recommended. It is considered possible that the magnetic line in section 7 may indicate the presence of an iron formation and possibly the expenditure of a small amount of money in testing this area is warranted. Much of the work done in exploration for iron ore is wasted because of failure to make intelligent use of the geologic and magnetic data to be obtained by a careful preliminary survey and, because the geologic information given by the drill is not properly used as a guide for further work. The value of careful scientific methods of exploration therefore cannot be too strongly emphasized. If exploration is contemplated in this township the discussion of this subject in Chapter VI should be carefully studied.

## TOWNSHIP 35 N., RANGE 7 W.

*Surface Features.*—Most of this township is a flat sandy plain. The northwestern and eastern portions are gently undulating. Streams tributary to the Chippewa river have dissected the flat central portion to some extent.

Most of the roads are fairly good though some stretches are very sandy. The timber has all been cut and agriculture is well developed in the area to the west of the Chippewa river. The Arpin Hardwood Lumber Company has a mill at Atlanta. This company operates a railroad between Bruce and Exeland which will be a very important factor in the development of agriculture in the tributary territory.

*Glacial Drift.*—The eastern and northwestern portions of this township are gently undulating ground moraine. The remainder is an outwash plain which is in general very level. Along the streams tributary to the Chippewa river there is some dissection. The glacial deposits are sand, gravel and silt in the outwash area; silt, sand and gravel in the ground moraine.

There is ledge along Elder Creek in the northwestern part of section 29. Ledge is found in section 31 at a depth of 52 feet and in section 19 at a depth of 27 feet. The indications are that the drift cover is relatively thin west of the Chippewa river, while to the east the thickness is somewhat greater.

*General Geology.*—But one outcrop of rock was found in this township. A rather soft, friable sandstone occurs along the banks of Elder creek about  $\frac{1}{4}$  mile south of the northwest corner of section 29. The formation is very well bedded, perfectly flat-lying, and is believed to be of Cambrian age. It has been quarried quite extensively for building stone. This sandstone was found at shallow depths in wells in sections 19 and 30. The pre-Cambrian rocks are not exposed and we have no positive indication of their character. Immediately to the west are igneous and sedimentary rocks of types found in the iron-bearing districts. Since these strike in a general direction toward this township, it is believed that similar rocks are likely to occur here but there is no indication of their presence other than the magnetic attractions in the northern part which suggest the presence of Huronian rocks.

*Magnetic Observations.*—A discussion of magnetic observations and their significance is given in Chapter IV. Over a considerable part of this township mild abnormal readings of the dip needle were

### TOWN 35 N., R. 7W.

Survey Made in August, 1914

Under the Direction of

W. O. HOTCHKISS, State Geologist

AND

E. F. BEAN and O. W. WHEELWRIGHT,  
in charge of Field Parties

BY

LOUIS ROARK, Chief of Party

G. M. EHLERS, Asst. Geologist

GEO. BELCHIC, Asst. Geologist

#### SYMBOLS AND ABBREVIATIONS.

The symbols and abbreviations used on this map are explained in Chapter II.

#### TOWN AND RANGE LINES.

In constructing this map the south line of the township was laid off as a true east west line. The other boundary lines were then laid off with the lengths shown on the Land Survey plat. Some of the maps are therefore incorrect in shape but this is necessary because definite facts are lacking. The acreage of part of the lots in the north and west tier of sections is shown to give a check on the distances in these sections.

#### LOCATIONS.

All locations are based on pacing traverses from government land corners. In many cases these were not found and it was necessary to continue the traverse several miles without a check. Locations of certain features may therefore be somewhat wrong. In such cases the feature sought may best be located by its relation to a stream, swamp, lake, or other feature shown on the map.

#### PROFILES.

The locations of the profiles are shown on the map by dashed blue lines with black letters at the ends. Railroad profiles were furnished by the companies and show elevations of the ground rather than track in most cases; others are from road surveys by the State Highway Commission; most of them are hand level lines made by this Survey. Wherever possible the elevations above sea level are given. These elevations vary from 1050 to 1770 feet. A local datum plane was necessarily assumed in some cases. These cases are identifiable by the fact that the base line is always numbered 0.

#### LAND CLASSIFICATION.

This is shown on the map by the blue letters. It is explained in the following township description and at length in chapter V.

#### MAGNETIC DATA.

Dial compass readings are shown in blue figures. Eastward declinations are shown with a dot to the east and westward with a dot to west of the number. Dip needle readings are shown in black. All are positive except those preceded by the negative sign. All readings show deviation of needles from the normal reading of the instrument used. Normal readings are omitted from the map except at each quarter section corner. All abnormal readings are shown.

Traverses were made on lines indicated—usually the N-S section and quarter lines. Dip needle readings were taken each 50 paces, dial compass readings each 100 paces when sun permitted.

Magnetic lines are indicated by heavy black lines, solid where definite and dashed where doubtful.

**CAUTION:** Almost any kind of rock may be the cause of magnetic attraction. Do not fail to read the following description of this township, and also chapter IV., in which the magnetic attractions are discussed.

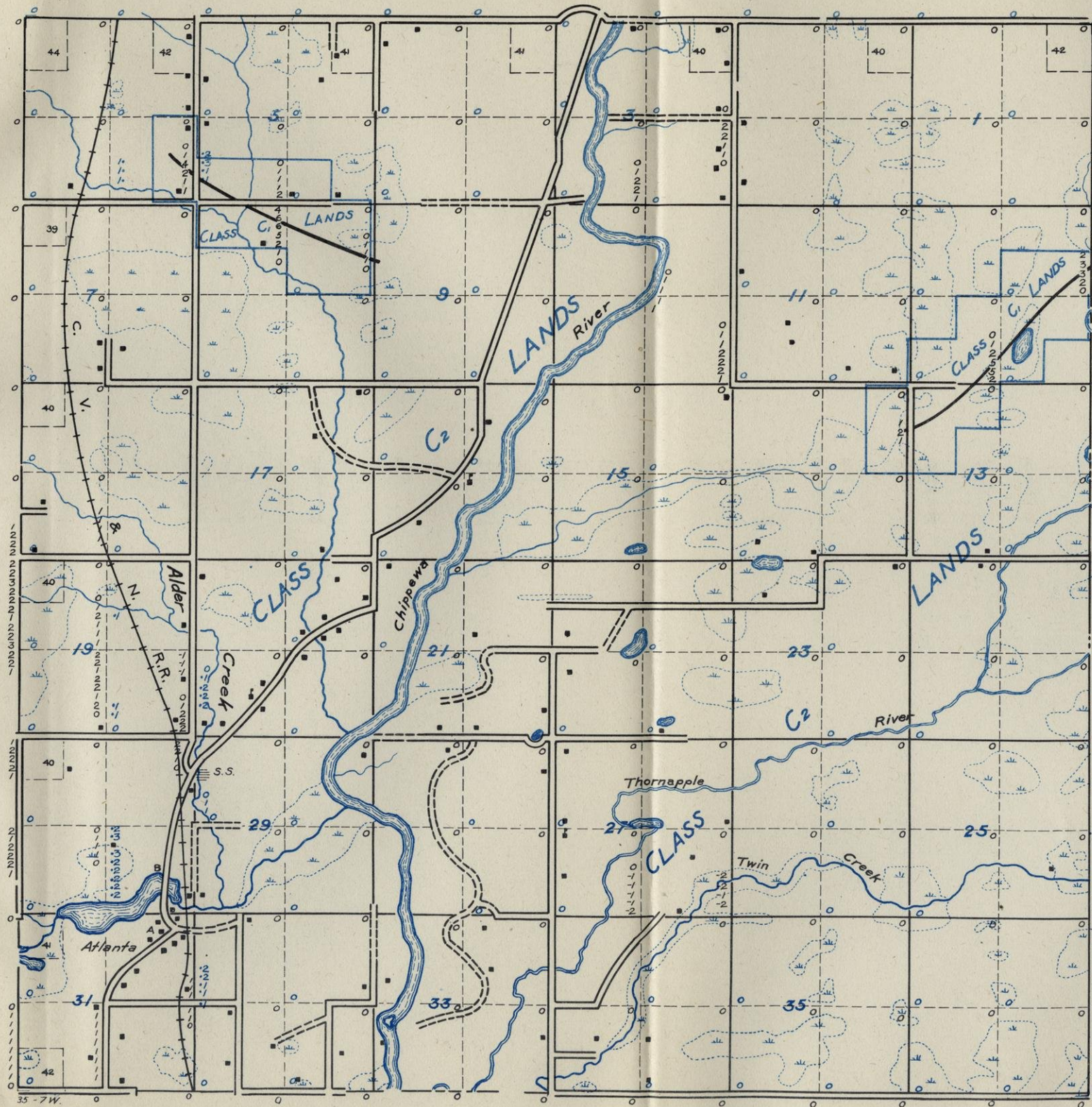

recorded, but most of them are irregular in character, and do not form good lines. The negative readings in the southeastern part are believed to indicate the presence of igneous rocks. The fairly well defined lines of attraction which occur in sections 12, 13, and 14 and crossing sections 5, 6, and 7 are probably caused by sedimentary formations.

*Land Classification.*—The principles of land classification employed in this work are discussed in Chapter V. Lands on the magnetic lines in sections 5, 6, and 8, and 12, 13, and 14, are classed as C1. All other lands in the township are placed in class C2.

*Exploration.*—Exploration for iron ore in this township is not especially recommended at present but later developments may make it appear advisable to do some work in the class C1 lands. The first work done should be along the well defined magnetic lines to determine whether or not they indicate the presence of iron formation. Much of the work done in exploration for iron ore is wasted because of failure to make intelligent use of the geologic and magnetic data to be obtained by a careful preliminary survey, and because the geologic information given by the drill is not properly used as a guide for further work. The value of careful scientific methods of exploration therefore cannot be too strongly emphasized. If exploration is contemplated in this township the discussion of this subject in Chapter VI should be carefully studied.

## TOWNSHIP 35 N., RANGE 8 W.

*Surface Features.*—The southeastern part of this township is flat to gently undulating. The northwestern part, underlain by the Barron quartzite, is higher and much more rugged.

The roads in the southeast are good. There is some hardwood left in the northeastern and western portion of the township. The southern and eastern parts are well settled.

*Glacial Drift.*—The striking topographic features are not due to glacial deposits but to the quartzite. In the southeastern part is a flat outwash plain. In the western and northwestern part is hummocky terminal moraine. The remainder of the township is gently undulating ground moraine southeast of the quartzite, and a thin veneer of ground moraine over the quartzite. The glacial deposits are largely sand and silt in the outwash areas; sand, gravel and silt with boulders in the terminal moraine; and silt, sand, and boulders in the ground moraine.

The drift is very thin in the central and northwestern part. In the southeast rock probably will be found at depths of from 25 to 60 feet in the uplands and at greater depths along Devil Creek. Outside the above mentioned areas the thickness of drift is not definitely known, except that near the E.  $\frac{1}{4}$  S. of section 16 rock is found at a depth of 150 feet.

*General Geology.*—The Barron quartzite is found in the northwest third of this township and several exposures are found along the eastern edge of the formation. The locations of the outcrops, together with the strike and dip of the rock are shown on the map. The strike is uniformly to the east of north and the dip is westward and very gentle.

The most interesting exposure is located on the section line between sections 17 and 20, a short distance east of the quarter post. The quartzite caps a very high hill which can be seen from a long distance and from the top of which one can view the country for many miles around.

The exposure consists of a vertical face of rock about 40 feet high along the foot of which test pits have exposed about 30 feet of the lower beds and penetrate the older rocks at the base. The exposed rock is a well indurated quartz sand having a pinkish color but the test pits in the bottom beds show a massive, soft, coarse sandstone

which grades upward into the quartzite. In other places in this vicinity the Barron formation is thoroughly cemented down to its base.

Lying unconformably below the quartzite is a reddish ferruginous slate. Because of partial filling of the pits this is not exposed in place but much has been thrown out of them and some large blocks show the contact between the two rocks. The bedding at the contact forms an angle of about  $70^\circ$ . Conglomerate is almost entirely lacking at the base of the Barron formation but occasional pieces of slate occur in the first few inches.

In other places where exposed, the quartzite is similar to the upper part of this outcrop. The strike is uniformly to the east of north and the dip always west at a low angle. The soft sandstone phase is not seen at any other point in this township but is found in several locations in adjoining townships.

In the west half of section 16 are a number of test pits in slates, and outcrops of slates and schistose greenstone are shown on or near Devil Creek. The former vary from a greenish yellow chloritic slate to dark red, highly ferruginous, cherty slates. The latter rock has served to encourage exploration for iron ore from time to time. The strike of the slate and of the schistosity in the green schists is about N.  $80^\circ$  W. and the dip  $80^\circ$  north.

A well at the school house near the E.  $\frac{1}{4}$  S. of section 16 was drilled to a depth of about 250 feet and from samples furnished by Mr. Oliver L. Olson was found to have cut chloritic schist after passing through 150 feet of glacial drift. The upper part of the schist was completely oxidized to red clay but as depth was reached the rock became fresher.

Fine-grained greenstone outcrops in the N. W.  $\frac{1}{4}$  of section 1. Although less schistose than in section 16 it is the same type of rock and its presence here suggests that the slates may also exist in this part of the township. There is little doubt that these slates and greenstones are of Huronian age and it is probable that Huronian rocks underlie all of this township, being covered by the Barron quartzite to a considerable extent in the north and west sides and to some extent by the Cambrian sandstone in the southeastern part. Sandstone was reported from 2 wells in sections 25 and 26. This probably belongs to the Cambrian which is exposed 2 miles east.

*Magnetic Observations.*—A general discussion of magnetic observations and their significance will be found in chapter IV. Mild positive and negative attractions were found in the eastern

and southeastern parts of the township but most of them do not connect to form a line. A poorly defined line extends from section 36 into the township to the south. The cause of these attractions is not known but it is very doubtful if they are due to iron formation.

*Land Classification.*—For a discussion of the principles of land classification employed in this work the reader is referred to chapter V. Lands in the immediate vicinity of the slates exposed in sections 16, 17 and 21 are placed in class B, because of the presence of a class of rock commonly associated with iron formation in the Lake Superior districts. No evidence of an iron formation was found, and in certain forties sufficient exploration has been done to indicate its absence for that property.

All other lands are classed as C2, although some of the area near the B lands may offer even better prospects for ore than the B lands themselves, but for lack of information the B classification was not extended beyond the area where the slates are known to exist.

*Exploration.*—Some drilling and test pitting has recently been done by Mr. O. L. Olson in the S. W.  $\frac{1}{4}$  of section 17 but his results have not been made public. There are also a number of old pits in sections 16, 17 and 20, most of which are shown on the map.

While there is no assurance that iron formation exists, its discovery is not improbable. There is nothing to indicate where, in the general locality of the slates, search should be made. It is pointed out that the B lands should not receive all of the attention. If exploratory work is contemplated it should not be confined to small localities with the idea that these slates will concentrate to an ore. An iron formation must first be located and, to do this, work must be carried on in a broad and systematic way over a considerable territory. Much of the work done in exploration for iron ore is wasted because of failure to make intelligent use of the geologic and magnetic data to be obtained by a careful preliminary survey, and because the geologic information given by the drill is not properly used as a guide for further work. One of the most common errors is drilling closely spaced holes in an entirely barren formation. The value of careful scientific methods of exploration therefore cannot be too strongly emphasized. If exploration is contemplated in this township the discussion of this subject in chapter VI should be carefully studied.



# TOWN 35 N., R. 8W.

Survey Made in July, 1914

Under the Direction of

W. O. HOTCHKISS, State Geologist

AND

E. F. BEAN and O. W. WHEELWRIGHT,  
in charge of Field Parties

BY

LOUIS ROARK, Chief of Party

G. M. EHLERS, Asst. Geologist

GEO. BELCHIC, Asst. Geologist

### SYMBOLS AND ABBREVIATIONS.

The symbols and abbreviations used on this map are explained in Chapter II.

### TOWN AND RANGE LINES.

In constructing this map the south line of the township was laid off as a true east west line. The other boundary lines were then laid off with the lengths shown on the Land Survey plat. Some of the maps are therefore incorrect in shape but this is necessary because definite facts are lacking. The acreage of part of the lots in the north and west tier of sections is shown to give a check on the distances in these sections.

### LOCATIONS.

All locations are based on pacing traverses from government land corners. In many cases these were not found and it was necessary to continue the traverse several miles without a check. Locations of certain features may therefore be somewhat wrong. In such cases the feature sought may best be located by its relation to a stream, swamp, lake, or other feature shown on the map.

### PROFILES.

The locations of the profiles are shown on the map by dashed blue lines with black letters at the ends. Railroad profiles were furnished by the companies and show elevations of the ground rather than track in most cases; others are from road surveys by the State Highway Commission: most of them are hand level lines made by this Survey. Wherever possible the elevations above sea level are given. These elevations vary from 1050 to 1770 feet. A local datum plane was necessarily assumed in some cases. These cases are identifiable by the fact that the base line is always numbered 0.

### LAND CLASSIFICATION.

This is shown on the map by the blue letters. It is explained in the following township description and at length in chapter V.

### MAGNETIC DATA.

Dial compass readings are shown in blue figures. Eastward declinations are shown with a dot to the east and westward with a dot to west of the number. Dip needle readings are shown in black. All are positive except those preceded by the negative sign. All readings show deviation of needles from the normal reading of the instrument used. Normal readings are omitted from the map except at each quarter section corner. All abnormal readings are shown.

Traverses were made on lines indicated—usually the N-S section and quarter lines. Dip needle readings were taken each 50 paces, dial compass readings each 100 paces when sun permitted.

Magnetic lines are indicated by heavy black lines, solid where definite and dashed where doubtful.

**CAUTION:** Almost any kind of rock may be the cause of magnetic attraction. Do not fail to read the following description of this township, and also chapter IV., in which the magnetic attractions are discussed.

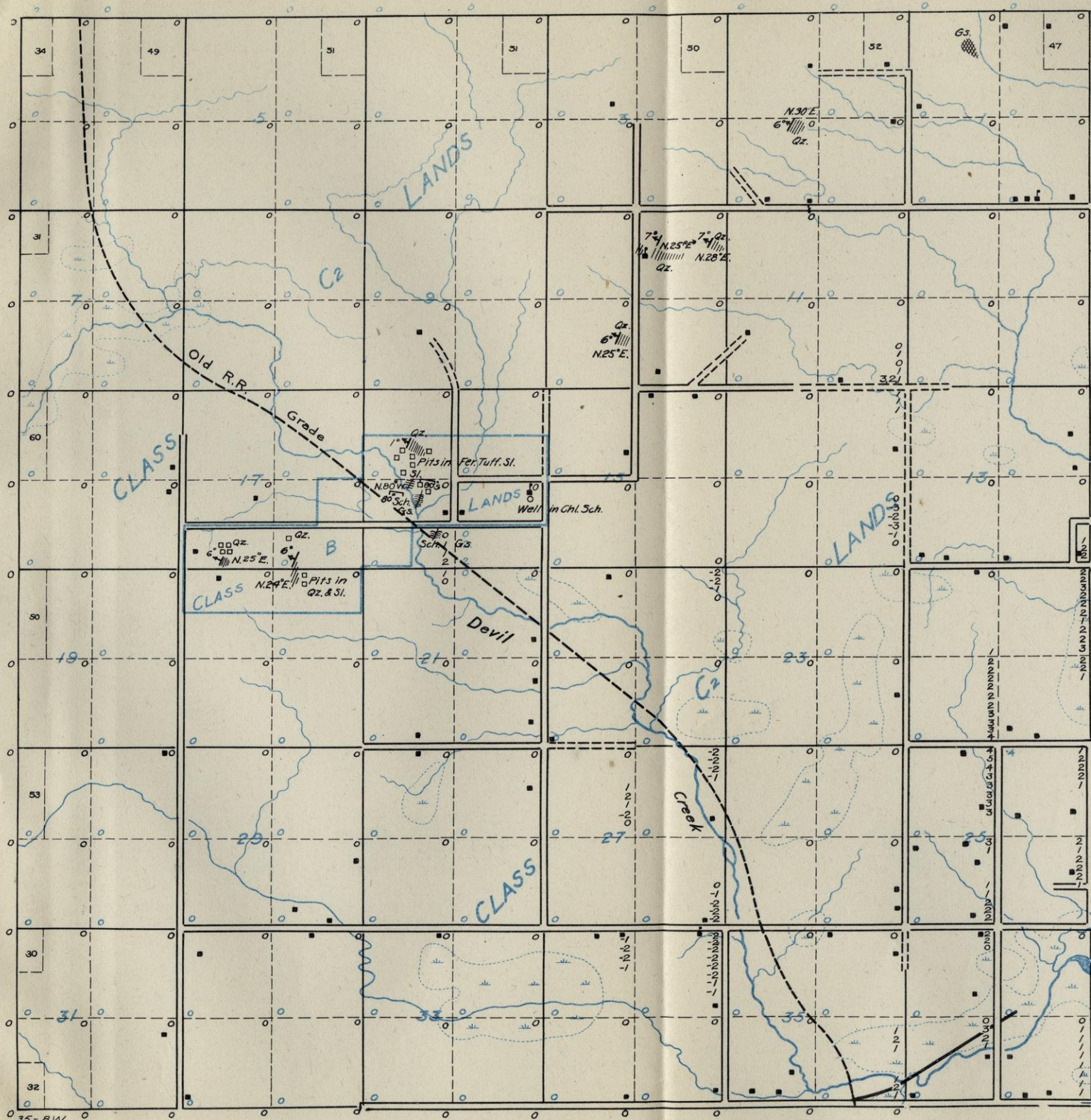

## TOWNSHIP 35 N., RANGE 9 W.

*Surface Features.*—This township is high, rising in places to at least 250 feet above the plain to the south. In the western third the upland is level to gently undulating, with numerous valleys cut in the quartzite. The eastern two-thirds is gently to roughly undulating. Here the topography is determined by the terminal moraine which masks most of the quartzite. The divide between the east flowing and west flowing streams runs north and south through the center of the township.

The accompanying profile shows the relief along the road. In section 30, Rock Creek flows through a gorge 50 feet deep in the quartzite. The road along the east line of section 32 makes a detour around a similar gorge. The only good road in the township is the one through sections 19 and 20. Hardwood covers most of the township. In the eastern sections there is considerable hemlock. There are some prosperous stock farms in sections 19 and 20, but the major portion of the township is still unsettled.

*Glacial Drift.*—The east two-thirds of the township is terminal moraine. In the southeast portion of this moraine area the hills have a local relief of 75 feet. The west third is gently undulating ground moraine, making a thin veneer over the quartzite. The glacial deposits of silt, some sand and gravel, and numerous boulders in the terminal moraine; silt, some sand and boulders in the ground moraine.

In the west third of the township numerous outcrops show that the drift cover is thin. It is undoubtedly heavier in the eastern part but it is not thought that it will exceed 75 feet, except possibly in the southeast corner.

*General Geology.*—Distributed generally over the west half of the township are numerous outcrops of the Barron quartzite. The ledge is usually covered with talus slopes and in many cases no rock is found in position. The rock is a rather fine-grained pink quartzite, usually well cemented, but at times almost as soft as sandstone. This sandy phase in places has been cemented by iron oxide in vein like forms which usually follow joints and less frequently, the bedding planes. Pipestone in thin seams is found in section 30, but it makes up but a very small part of the entire formation. On the east side of the township but one outcrop was found, that in section 24.

The strikes observed vary from E.-W. to N. 45° E. and the dips are N. or N. W. at angles varying from 3 to 25°. It is quite certain that the quartzite underlies the whole township. From general considerations, which are discussed in chapter III, it is believed that the thickness of this formation does not exceed 600 feet and that it is much thinner in this township. Nothing whatever is known of the character of the older rocks beneath the quartzite but from information obtained in the township to the east it seems probable that they may be, to some extent at least, sediments of Huronian age. If such is the case, the existence of iron formation is not improbable.

*Magnetic Observations.*—No abnormal attractions are detected in this township.

*Land Classification.*—The principles of land classification employed in this work are discussed in chapter V. As stated above, the Barron quartzite probably covers all of this township, but it is considered to be so thin that it would not materially interfere with mining operations in the event of the discovery of ore in the older rocks beneath, so it is not taken into consideration in classifying the lands.

All lands are classed as C2 because nothing is known of the character of the formations beneath the quartzite, and no magnetic attraction was found.

*Exploration.*—Exploration for iron ore in this township is not warranted until some information is obtained which may indicate the presence of iron formation. The results of this Survey give no clue whatever to guide explorers in the search for ore.

# TOWN 35 N., R. 9W.

Survey Made in June, 1914

Under the Direction of

W. O. HOTCHKISS, State Geologist

AND

E. F. BEAN and O. W. WHEELWRIGHT,  
in charge of Field Parties

BY

W. I. ROBINSON, Chief of Party

S. M. WILLIS, Asst. Geologist

G. M. SCHWARTZ, Asst. Geologist

### SYMBOLS AND ABBREVIATIONS.

The symbols and abbreviations used on this map are explained in Chapter II.

### TOWN AND RANGE LINES.

In constructing this map the south line of the township was laid off as a true east west line. The other boundary lines were then laid off with the lengths shown on the Land Survey plat. Some of the maps are therefore incorrect in shape but this is necessary because definite facts are lacking. The acreage of part of the lots in the north and west tier of sections is shown to give a check on the distances in these sections.

### LOCATIONS.

All locations are based on pacing traverses from government land corners. In many cases these were not found and it was necessary to continue the traverse several miles without a check. Locations of certain features may therefore be somewhat wrong. In such cases the feature sought may best be located by its relation to a stream, swamp, lake, or other feature shown on the map.

### PROFILES.

The locations of the profiles are shown on the map by dashed blue lines with black letters at the ends. Railroad profiles were furnished by the companies and show elevations of the ground rather than track in most cases; others are from road surveys by the State Highway Commission; most of them are hand level lines made by this Survey. Wherever possible the elevations above sea level are given. These elevations vary from 1050 to 1770 feet. A local datum plane was necessarily assumed in some cases. These cases are identifiable by the fact that the base line is always numbered 0.

### LAND CLASSIFICATION.

This is shown on the map by the blue letters. It is explained in the following township description and at length in chapter V.

### MAGNETIC DATA.

Dial compass readings are shown in blue figures. Eastward declinations are shown with a dot to the east and westward with a dot to west of the number. Dip needle readings are shown in black. All are positive except those preceded by the negative sign. All readings show deviation of needles from the normal reading of the instrument used. Normal readings are omitted from the map except at each quarter section corner. All abnormal readings are shown.

Traverses were made on lines indicated—usually the N-S section and quarter lines. Dip needle readings were taken each 50 paces, dial compass readings each 100 paces when sun permitted.

Magnetic lines are indicated by heavy black lines, solid where definite and dashed where doubtful.

**CAUTION:** Almost any kind of rock may be the cause of magnetic attraction. Do not fail to read the following description of this township, and also chapter IV., in which the magnetic attractions are discussed.

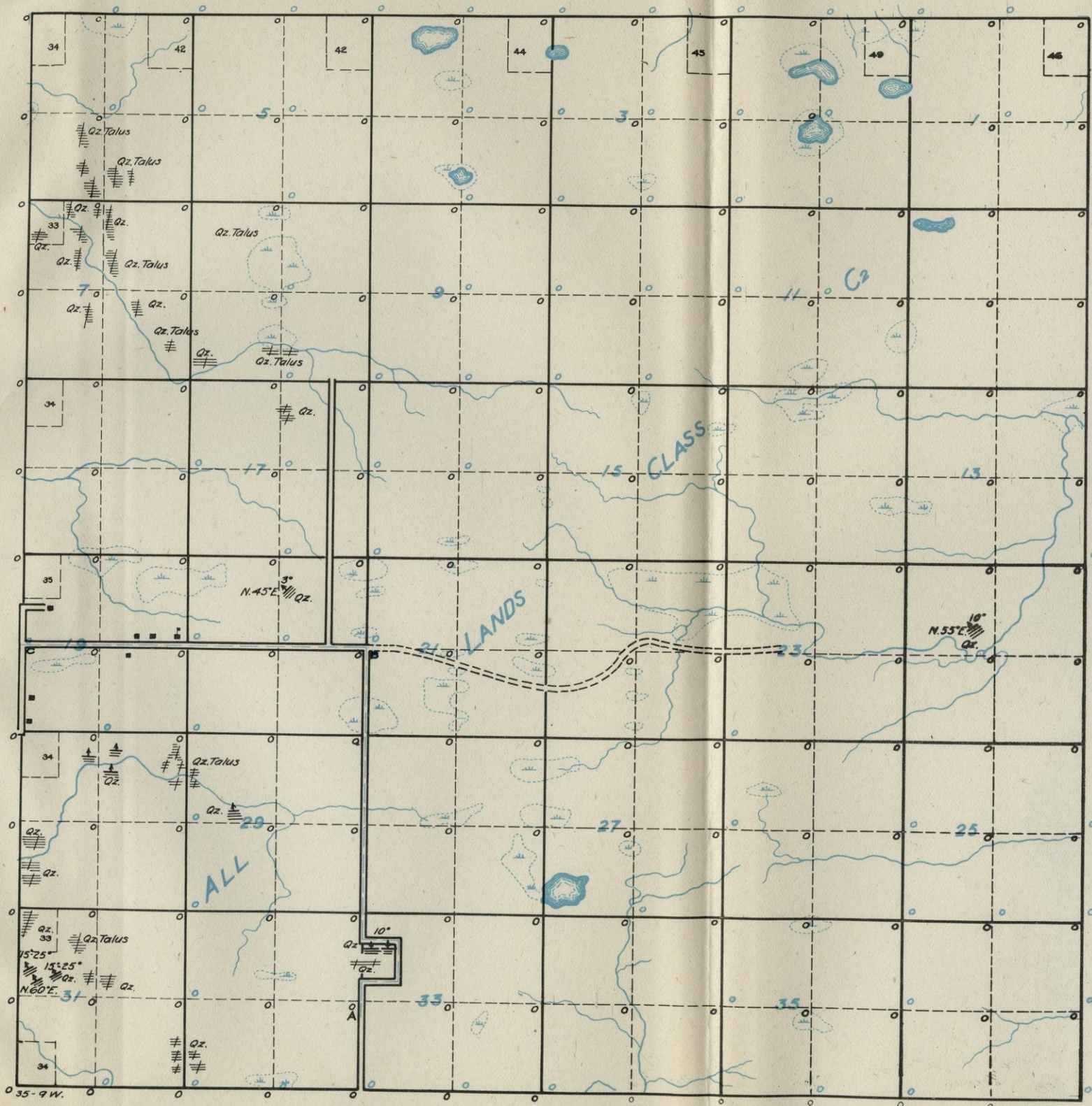

PROFILE

VERTICAL SCALE: 1 space = 20'  
HORIZONTAL SCALE: same as map



## TOWNSHIP 35 N., RANGE 10 W.

*Surface Features.*—The eastern and southern parts of this township are underlain by quartzite, covered with a thin veneer of drift. The topography is essentially that of preglacial times. Between the valleys are areas of flat upland broken here and there by quartzite ridges. In the northwest is a broad plain broken in a few places by stream erosion.

Profile A-B shows the level topography of the plain. Profile C-D illustrates the level topography of the plain in the northwestern part of the township and the rugged topography of the northeastern part. The roads in the more level portions of the township are good. The timber is confined to the quartzite area in the south and east, where considerable hardwood is still standing. A large part of the population is found in the flat area where there are numerous well improved farms.

*Glacial Drift.*—Over most of the quartzite there is a veneer of ground moraine. In the northeastern part of the township there is an area of terminal moraine, very weak to the west, but stronger to the east. In the northwest is an area of outwash. Glacial deposits are largely silt and boulders in the ground moraine; silt, sand, and boulders in the terminal moraine; sand and silt in the outwash.

The drift covering in the quartzite area is very thin. In the terminal moraine and outwash well records indicate that the drift is at least 80 feet in thickness.

*General Geology.*—Over the southeast half of the township many outcrops of the Barron quartzite occur at the locations indicated on the map. The rock is a light pink to dark red in color. It is composed principally of moderately fine sand grains thoroughly cemented and containing at times small pebbles of quartz up to  $\frac{1}{4}$  inch in diameter. Many of the outcrops mapped are merely talus slopes where no ledge in place is exposed. However, a number of them show the rock in position and make it possible to obtain strike and dip determinations. While some variation is shown, the general strike is about N. E. and the dip N. W. at an angle varying from  $5^{\circ}$  to  $20^{\circ}$ . The occurrence of thin layers of pipestone is common but this makes up very little of the entire bulk of the formation. During the early days the Indians quarried this rock more or less for the manufacture of pipes. Their principal and most famous quarry was located in the S. E. corner of section 27, and is described by Cham-

berlin in Volume 4 of the Geology of Wisconsin. Near the N. W. corner of section 14 a number of test pits were put down about 25 years ago in search for iron ore, and it is reported that some drilling was also done here. No definite records of this work have been preserved. However, the pits show that the rock encountered was a diabase, in some cases very little altered and in others completely altered to a red clay product which was erroneously thought to be iron formation. The relations of this formation to the quartzite are not clear. It may be intrusive or it may be a part of the underlying Huronian series.

There is no doubt that all that half of the township showing outcrops and talus is underlain by the Barron formation, but it is not certain that any occurs in the other half. Two wells, one in the N. E. corner of 16 and one at the N. E. corner of 10, were reported to have encountered quartzite at a depth of 75 feet, but there is some question as to whether or not this was ledge. The valley of Pakegama creek may possibly have been cut through the quartzite in 30 and 31, but the underlying Huronian rocks are not exposed along its banks.

*Magnetic Observations.*—The township map shows a few areas in which irregular mild dip needle readings were found, but these are not thought to be of any importance.

*Land Classification.*—The principles of land classification employed in this work are discussed in Chapter V. The Barron quartzite is a non-productive formation but is not thought to be thick in this township. The older rocks beneath may carry iron formation, and on account of this fact all lands in the township are placed in class C2.

*Exploration.*—Exploration for iron ore is not recommended in this township. The work previously done in section 14 was a waste of money so far as prospects of finding iron ore are concerned. This does not mean that iron formation is not present but since there is no evidence of its existence there is very little chance that exploration would prove successful.

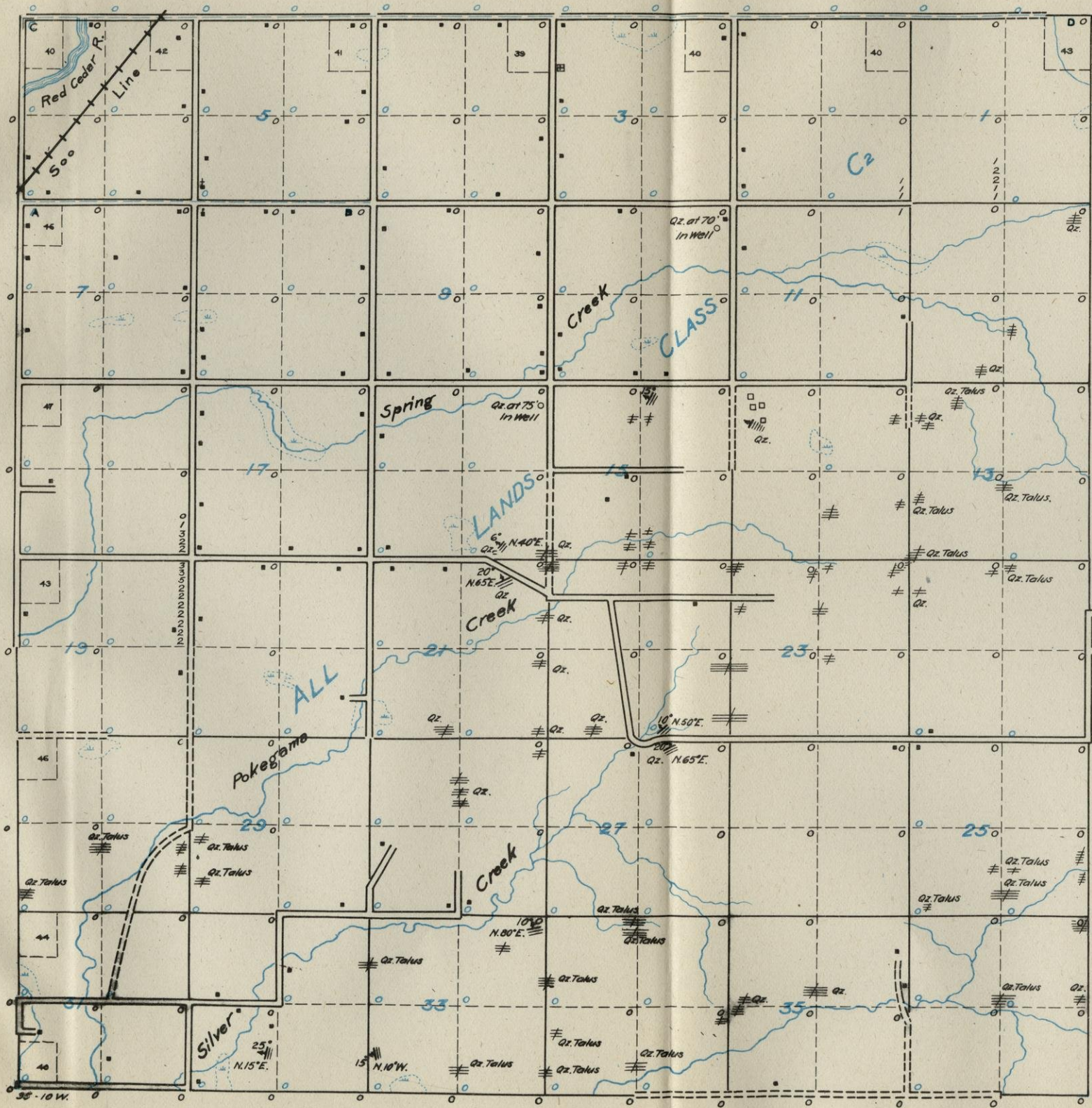

PROFILE  
 VERTICAL SCALE: 1 space = 20  
 HORIZONTAL SCALE: same as map  
 LOCAL DATUM

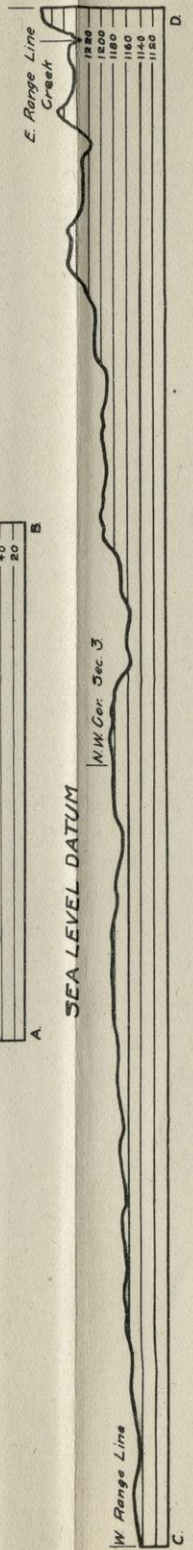
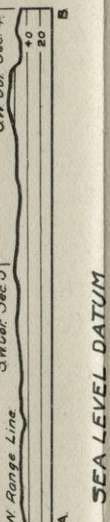

TOWN 35 N., R. 10 W.

Survey Made in July, 1914

Under the Direction of  
 W. O. HOTCHKISS, State Geologist  
 AND  
 E. F. BEAN and O. W. WHEELWRIGHT,  
 in charge of Field Parties  
 BY  
 W. I. ROBINSON, Chief of Party  
 S. M. WILLIS, Asst. Geologist  
 G. M. SCHWARTZ, Asst. Geologist

**SYMBOLS AND ABBREVIATIONS.**  
 The symbols and abbreviations used on this map are explained in Chapter II.

**TOWN AND RANGE LINES.**  
 In constructing this map the south line of the township was laid off as a true east west line. The other boundary lines were then laid off with the lengths shown on the Land Survey plat. Some of the maps are therefore incorrect in shape but this is necessary because definite facts are lacking. The acreage of part of the lots in the north and west tier of sections is shown to give a check on the distances in these sections.

**LOCATIONS.**  
 All locations are based on pacing traverses from government land corners. In many cases these were not found and it was necessary to continue the traverse several miles without a check. Locations of certain features may therefore be somewhat wrong. In such cases the feature sought may best be located by its relation to a stream, swamp, lake, or other feature shown on the map.

**PROFILES.**  
 The locations of the profiles are shown on the map by dashed blue lines with black letters at the ends. Railroad profiles were furnished by the companies and show elevations of the ground rather than track in most cases; others are from road surveys by the State Highway Commission; most of them are hand level lines made by this Survey. Wherever possible the elevations above sea level are given. These elevations vary from 1050 to 1770 feet. A local datum plane was necessarily assumed in some cases. These cases are identifiable by the fact that the base line is always numbered 0.

**LAND CLASSIFICATION.**  
 This is shown on the map by the blue letters. It is explained in the following township description and at length in chapter V.

**MAGNETIC DATA.**  
 Dial compass readings are shown in blue figures. Eastward declinations are shown with a dot to the east and westward with a dot to west of the number. Dip needle readings are shown in black. All are positive except those preceded by the negative sign. All readings show deviation of needles from the normal reading of the instrument used. Normal readings are omitted from the map except at each quarter section corner. All abnormal readings are shown.

Traverses were made on lines indicated—usually the N-S section and quarter lines. Dip needle readings were taken each 50 paces, dial compass readings each 100 paces when sun permitted.

Magnetic lines are indicated by heavy black lines, solid where definite and dashed where doubtful.

**CAUTION:** Almost any kind of rock may be the cause of magnetic attraction. Do not fail to read the following description of this township, and also chapter IV., in which the magnetic attractions are discussed.

## TOWNSHIP 36 N., RANGE 12 E.

*Surface Features.*—A line drawn from the east quarter post of section 13 to the northwest corner of this section, then southwest to the Wolf river near the center of section 20, then following south about  $\frac{1}{4}$  mile east of the river to the township line, separates this township into two areas of widely different topography. North and west of this line the surface varies from very gently undulating to flat. Drainage is very poor and fully 50 per cent is swamp or lake. The area is crossed by Wolf river, a deep sluggish stream which widens out in sections 17 and 20 to form Little Rice Lake. This lake is very shallow and has indistinct marshy shores.

In strong contrast with this is the high, rough, well-drained part of the township to the southeast. Going east from Wolf river at the center of section 20 there is a rise of 125 feet in the first half mile along the road. This general high elevation is maintained over most of the southeastern part. A very prominent hill occupies the area in the loop of the C. & N. W. Ry. The rest of this higher area is characterized by a series of nearly parallel hills trending slightly east of north and showing local relief from a few feet to about 100 feet. There is a marked north and south depression from  $\frac{1}{2}$  to 1 mile wide in the west sides of sections 24, 25, and 36. The accompanying profiles show some of these features although they do not cross the highest parts of the township. The grade of the C. & N. W. Ry., on the profile H-I is worthy of note. The highest measured point in the township is the hill in section 35 which is known to be over 1800 feet above sea level—see page 59.

The roads in the southeastern part of the township are good. Elsewhere they are very poor and, except in dry weather, are almost impassable. Considerable hardwood still remains, most of it in a belt  $1\frac{1}{2}$  miles wide lying east of Wolf river throughout its entire course in the township. Some timber is also found northwest of the stream. Logging operations are active. The southeastern part is well settled but lack of good roads prevents settlers from coming into the other parts of the township.

*Glacial Drift.*—Most of the area west of Wolf river is an outwash plain with occasional patches of uncovered ground moraine. The glacial drift consists of very fine sand and some gravel, with bouldery patches where the ground moraine is not covered by outwash. The flat area east of Wolf river in the northern part of the township is



ground moraine. The drift here consists of sand and gravel, with a covering of fine silt. Boulders are of common occurrence. Another outwash plain occurs in the low area in sections 24, 25, and 36 above described. It is much pitted along the east side. The drift here consists of sand and gravel.

The remainder of the higher portion of the township is principally terminal moraine although a strip 1 mile wide in sections 22, 27, 32, 33, and 34 is probably ground moraine. Most of the terminal moraine is of the ridge rather than of the knob and sag type. The drift is characteristically sandy and gravelly with a silt covering on the hill tops and gentler slopes.

The depths of drift will undoubtedly prove to be from 100 to 300 feet in the southeastern area but in the northern and western parts it is probably of moderate thickness, as indicated by the fact that rocks are exposed in a few places.

*General Geology.*—Three small exposures of rock were located. An outcrop of diorite occurs a short distance north of the southwest corner of section 10 and at the W.  $\frac{1}{4}$  S. of section 3 is a small exposure of granite gneiss. Two hundred paces south of this is an exposure showing granite gneiss and hornblende schist.

The presence, in the township west, of large numbers of exposures of igneous rock usually trending toward the east, suggests that this township is probably underlain by the same class of rock. However, exposures are so few that no statement of the facts can be made until work has been done in a broader area.

*Magnetic Observations.*—A general discussion of magnetic observations and their significance is given in Chapter IV. Very mild attraction was found in a few places where the drift covering is not heavy but no lines were found. These attractions are thought to indicate the existence of magnetite in the igneous rocks beneath.

*Land Classification.*—A general discussion of the principles of land classification employed in this work is given in Chapter V. Those lands upon which exposures of igneous rock were found are placed in class D. Because of doubt as to the character of the underlying rock all other lands are classed as C2.

*Exploration.*—There is nothing to indicate the presence of iron formation in this township and although these lands cannot be certainly condemned as mineral prospects, exploration is not recommended.

**TOWN 36 N., R. 12E.**

Survey Made in September, 1914

Under the Direction of  
**W. O. HOTCHKISS**, State Geologist  
AND  
**E. F. BEAN** and **O. W. WHEELWRIGHT**,  
in charge of Field Parties

BY  
**W. L. DOBIE**, Chief of Party  
**F. B. PLUMMER**, Asst. Geologist  
**O. W. POTTER**, Asst. Geologist  
**HOWARD QUINLAN**, Asst. Geologist

**SYMBOLS AND ABBREVIATIONS.**  
The symbols and abbreviations used on this map are explained in Chapter II.

**TOWN AND RANGE LINES.**  
In constructing this map the south line of the township was laid off as a true east west line. The other boundary lines were then laid off with the lengths shown on the Land Survey plat. Some of the maps are therefore incorrect in shape but this is necessary because definite facts are lacking. The acreage of part of the lots in the north and west tier of sections is shown to give a check on the distances in these sections.

**LOCATIONS.**  
All locations are based on pacing traverses from government land corners. In many cases these were not found and it was necessary to continue the traverse several miles without a check. Locations of certain features may therefore be somewhat wrong. In such cases the feature sought may best be located by its relation to a stream, swamp, lake, or other feature shown on the map.

**PROFILES.**  
The locations of the profiles are shown on the map by dashed blue lines with black letters at the ends. Railroad profiles were furnished by the companies and show elevations of the ground rather than track in most cases; others are from road surveys by the State Highway Commission; most of them are hand level lines made by this Survey. Wherever possible the elevations above sea level are given. These elevations vary from 1050 to 1770 feet. A local datum plane was necessarily assumed in some cases. These cases are identifiable by the fact that the base line is always numbered 0.

**LAND CLASSIFICATION.**  
This is shown on the map by the blue letters. It is explained in the following township description and at length in chapter V.

**MAGNETIC DATA.**  
Dial compass readings are shown in blue figures. Eastward declinations are shown with a dot to the east and westward with a dot to west of the number. Dip needle readings are shown in black. All are positive except those preceded by the negative sign. All readings show deviation of needles from the normal reading of the instrument used. Normal readings are omitted from the map except at each quarter section corner. All abnormal readings are shown.

Traverses were made on lines indicated—usually the N-S section and quarter lines. Dip needle readings were taken each 50 paces, dial compass readings each 100 paces when sun permitted.

Magnetic lines are indicated by heavy black lines, solid where definite and dashed where doubtful.

**CAUTION:** Almost any kind of rock may be the cause of magnetic attraction. Do not fail to read the following description of this township, and also chapter IV., in which the magnetic attractions are discussed.

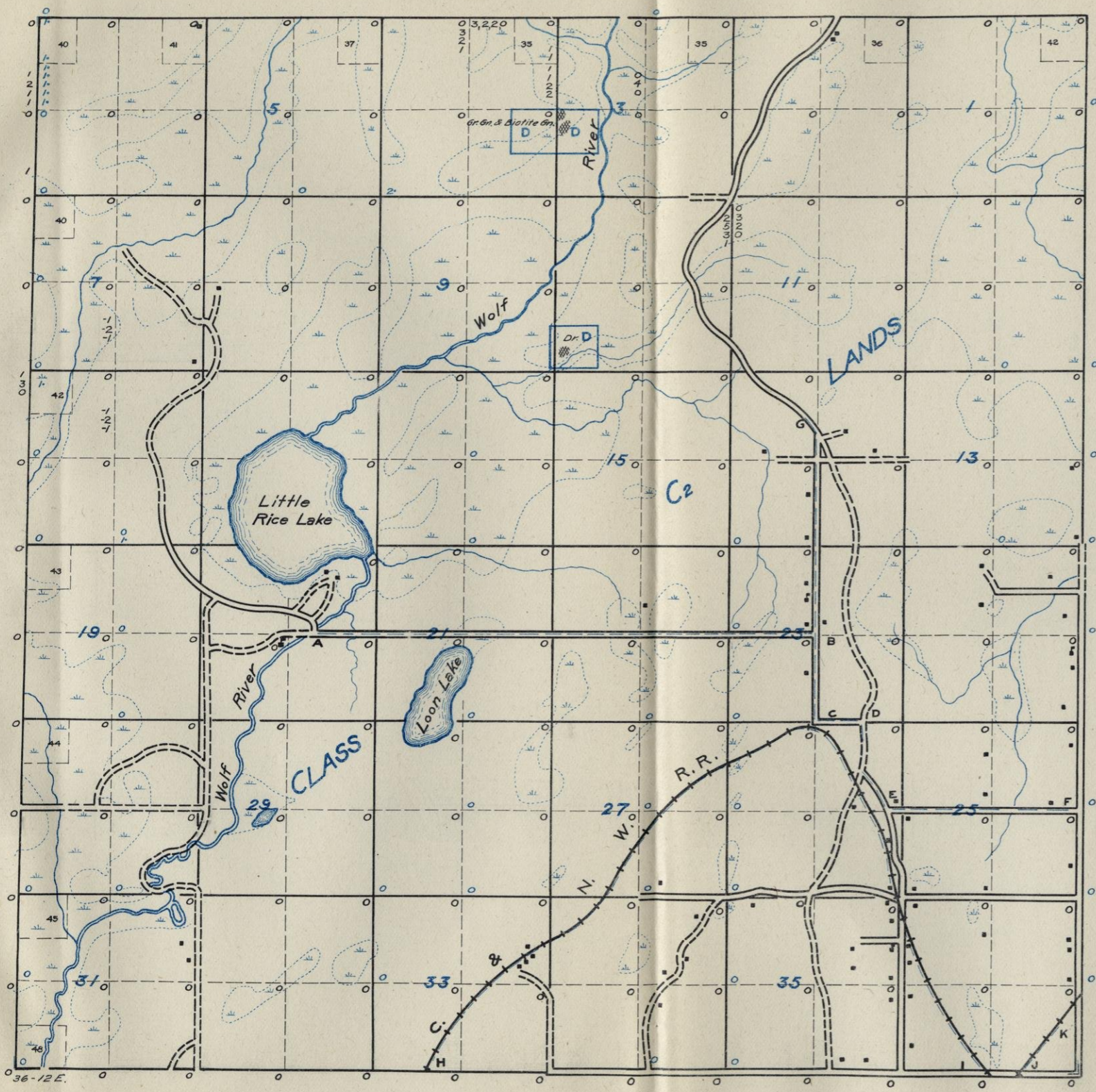

**PROFILES**  
VERTICAL SCALE: 1 space = 20'  
HORIZONTAL SCALE: same as map

SEA LEVEL DATUM

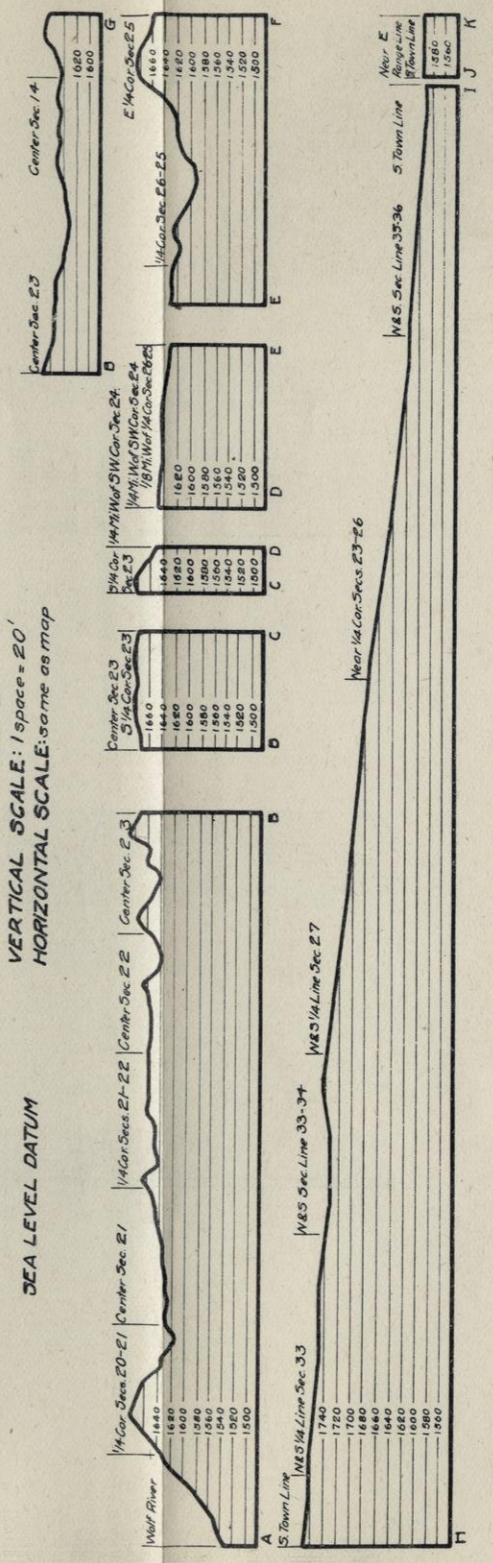

## TOWNSHIP 36 N., RANGE 11 E.

*Surface Features.*—Except in the southeastern part, this township is of low relief and poorly drained. A very large percentage of the surface is swampy ground. In the west half numerous rock hills give a markedly uneven surface and the southeastern part is rugged from inequalities in the surface of the glacial drift. Monico creek occupies a broad shallow depression which is not a noticeable feature but is well shown by the profile, C-D. From the profile A-B it will be noted that the southeastern quarter of the township is considerably higher than the other parts.

Roads are few and except near the village of Monico are in very poor condition. Considerable hardwood and hemlock still remains in this township and many of the swamps have good growths of cedar, spruce and tamarack. Logging operations are active at the present time. Settlement is progressing slowly and only in the immediate vicinity of Monico.

*Glacial Drift.*—Most of the township is covered with ground moraine deposits which are to some extent covered with a thin veneer of outwash. Many rock exposures protrude through the ground moraine. The drift consists of sand, gravel, and silt with many boulders, some of which are of enormous size. Terminal moraine occupies most of sections 24, 25, 26, 27, 34, 35, and 36. Rock exposures are lacking in this part of the township. The drift is markedly more silty than in the ground moraine and boulders are not as numerous. North of Monico a prominent ridge 2 miles long and half a mile wide has the appearance of terminal moraine. Patches of outwash sand occur in the west side of section 7; along the line between sections 15 and 22, and in the general vicinity of Monico. A long esker-like ridge extends from the east side of section 13 to the south quarter post of section 33. The drift is undoubtedly thin in all but the southeastern part and it is improbable that the thickness will exceed 100 feet at any point in the township.

*General Geology.*—Rock exposures are very numerous in the central and western parts. A large number are indicated on the map and undoubtedly many more would be found by closer work. All of the rocks are igneous and a wide range in composition and texture is shown. While most of the outcrops indicated on the map show two or more varieties of rock, contacts showing distinct relations are few. The intrusives are of both acid and basic rocks and there are occur-

rences of both varieties showing distinct flow structures. In most cases the granites and syenites appear to be intrusive but in other cases, as near the N.  $\frac{1}{4}$  S. of section 17, near the W.  $\frac{1}{4}$  S. of 18 and the N.  $\frac{1}{4}$  S. of 19 the greenstones are intrusive into the acid rocks. There is likewise great variation in the degree of metamorphism to which the rocks have been subjected. Much of the granite is distinctly gneissic while the syenites and some of the granites show but little effects of pressure. In the N.  $\frac{1}{2}$  of section 8 and the N. E.  $\frac{1}{4}$  of section 17 are well developed hornblende schists. Chlorite is very largely developed in the finer greenstones in many places. On the other hand many of the diorites and diabases show little effects of pressure. The complications are such that it is not worth while at present to attempt to work out the relations of the igneous rocks.

Here as in the township to the west the most southerly outcrops are nearly all fine grained greenstones. Many of them show distinct flow structure. It is possible that there may be a sedimentary series south of them but this is extremely doubtful. However, because of this possibility and the occurrence of a somewhat irregular magnetic line the southern part has been mapped as a possible Huronian belt. Although no rocks are exposed in the northeastern part it is assumed that the same rocks occur here as to the west.

*Magnetic Observations.*—A general discussion of magnetic observations and their significance is given in Chapter IV. Near the south township line most of the traverses crossed mild belts of attraction which connect up to form a fairly definite line, but owing to the fact that greenstone is found outcropping directly under the strongest attractions it is not considered as favorable indication of the presence of iron formation. Other small areas of irregular attraction were found but they are near outcrops of igneous rock and it is probable that magnetite in these rocks causes the attraction.

*Land Classification.*—A general discussion of the principles of land classification employed in this work is given in Chapter V. All lands in that portion of the township where outcrops are of common occurrence are placed in class D. All others are placed in class C2 because of doubt as to the character of the underlying rock.

*Exploration.*—Exploration in this township is not recommended. It is reasonably certain that no iron formation will be found in that part in which outcrops are of common occurrence. The remainder cannot be condemned as being certainly barren mineral lands, but there are no indications at present to encourage the expenditure of money in drilling.

TOWN 36 N., R. 11E.

Survey Made in September, 1914

Under the Direction of  
W. O. HOTCHKISS, State Geologist  
AND  
E. F. BEAN and O. W. WHEELWRIGHT,  
in charge of Field Parties

BY  
W. L. DOBIE, Chief of Party  
O. W. POTTER, Asst. Geologist  
HOWARD QUINLAN, Asst. Geologist

**SYMBOLS AND ABBREVIATIONS.**  
The symbols and abbreviations used on this map are explained in Chapter II.

**TOWN AND RANGE LINES.**  
In constructing this map the south line of the township was laid off as a true east west line. The other boundary lines were then laid off with the lengths shown on the Land Survey plat. Some of the maps are therefore incorrect in shape but this is necessary because definite facts are lacking. The acreage of part of the lots in the north and west tier of sections is shown to give a check on the distances in these sections.

**LOCATIONS.**  
All locations are based on pacing traverses from government land corners. In many cases these were not found and it was necessary to continue the traverse several miles without a check. Locations of certain features may therefore be somewhat wrong. In such cases the feature sought may best be located by its relation to a stream, swamp, lake, or other feature shown on the map.

**PROFILES.**  
The locations of the profiles are shown on the map by dashed blue lines with black letters at the ends. Railroad profiles were furnished by the companies and show elevations of the ground rather than track in most cases; others are from road surveys by the State Highway Commission; most of them are hand level lines made by this Survey. Wherever possible the elevations above sea level are given. These elevations vary from 1050 to 1770 feet. A local datum plane was necessarily assumed in some cases. These cases are identifiable by the fact that the base line is always numbered 0.

**LAND CLASSIFICATION.**  
This is shown on the map by the blue letters. It is explained in the following township description and at length in chapter V.

**MAGNETIC DATA.**  
Dial compass readings are shown in blue figures. Eastward declinations are shown with a dot to the east and westward with a dot to west of the number. Dip needle readings are shown in black. All are positive except those preceded by the negative sign. All readings show deviation of needles from the normal reading of the instrument used. Normal readings are omitted from the map except at each quarter section corner. All abnormal readings are shown.

Traverses were made on lines indicated—usually the N-S section and quarter lines. Dip needle readings were taken each 50 paces, dial compass readings each 100 paces when sun permitted.

Magnetic lines are indicated by heavy black lines, solid where definite and dashed where doubtful.

**CAUTION:** Almost any kind of rock may be the cause of magnetic attraction. Do not fail to read the following description of this township, and also chapter IV., in which the magnetic attractions are discussed.

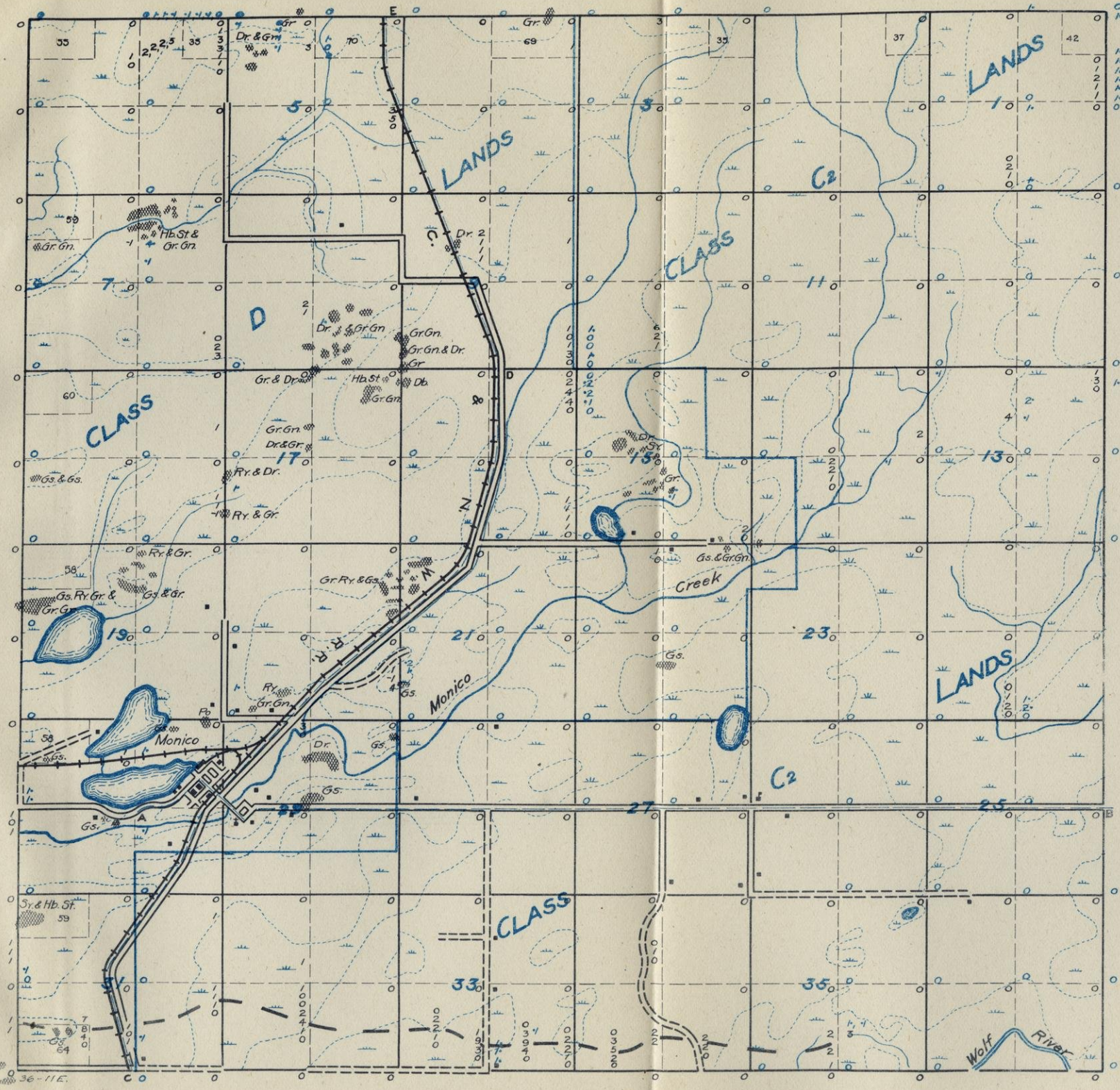

**PROFILES**  
VERTICAL SCALE: 1 space = 20'  
HORIZONTAL SCALE: Same as map

SEA LEVEL DATUM

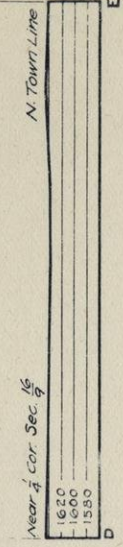
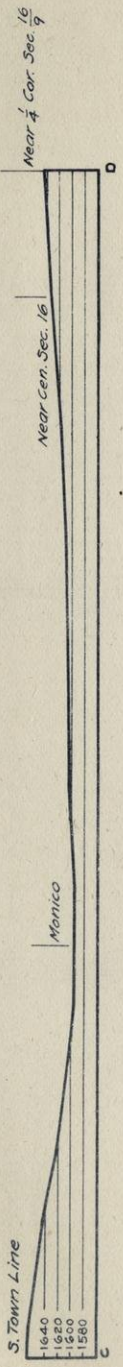
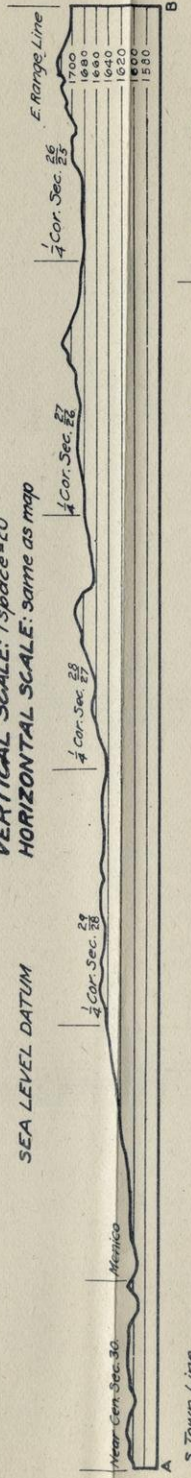

## TOWNSHIP 36 N., RANGE 10 E.

*Surface Features.*—The surface of this township is gently rolling except for a few small areas of rough ground described below and some nearly flat areas as in the eastern part of section 25, an area in sections 10, 15 and 16, comprising about 600 acres, and a small area in sections 19 and 20. Most of that part northwest of Pelican river is nearly flat. All over the township large areas of undrained land are found and nearly 50 per cent of the surface is either swamp or lake. In sections 3 and 4 and on the west side of sections 19 and 30 are small patches of rough hummocky ground, and fairly prominent ridges with gentle slopes occur in the center of sections 10 and 11, west of the wagon road in section 16, and in the center of section 36. Some of the rocky ridges in section 23 also stand out slightly above the general level of the country. Local relief of more than 60 or 70 feet is unknown, and in only a very few instances is the relief more than 30 or 40 feet. The accompanying profiles give a very fair idea of the topography as well as the general elevation in this township.

Roads are very few and in poor condition. The main road crossing the township from east to west is little used and is nearly impassable in places. The original timber in this township was mostly pine and has been nearly all removed. Some hemlock and hardwood still remain in sections 31 and 36 and a few patches of small pine trees are to be found here and there. Because of the sandy soil, numerous bowlders, and great swamp areas, agricultural development is very slow.

*Glacial Drift.*—All of the township has been covered by glacial drift although rock protrudes through it in many places. Much of the drift is ground moraine and consists of sand, gravel and numerous bowlders, many of which are of great size. Patches of outwash are found in the east side of section 12, the east of section 25, along the line between sections 19 and 20, and over an area of 600 acres in sections 11, 15 and 16. There is also much outwash material partly covering the ground moraine northwest of Pelican river. The outwash deposits consist almost entirely of sand with some fine gravel, bowlders being conspicuously absent. Pronounced terminal moraine is found in parts of sections 3 and 4; in the form of a ridge in sections 10 and 11, and in a narrow strip along the west side of sections 19 and 30. The knob and sag topography is well shown but relief is not very great. Here, as in the ground

moraine, the drift is characteristically sandy and boulders are common.

From the number of exposures of rock found it is believed that the depth of drift is nowhere very great.

*General Geology.*—Rock outcrops are very common, as shown on the township plat, and undoubtedly many occur which were not seen in making this survey. All exposures are of igneous rock varying in composition from the dark basic varieties to light acid rocks, and in texture from rocks so fine-grained that no crystals can be distinguished, to the coarse granitic varieties. Most of the basic and some of the acid rocks represent surface flows but intrusive varieties of both are also shown.

Near the southeast corner of section 34 an outcrop of very fine grained green schist shows a well developed slaty cleavage and has the appearance of possibly being a sediment. It is but a few feet thick and is in contact on the north side with gabbro and on the south side with coarse diorite. The rock is probably of igneous origin. There is no other suggestion of sedimentary rocks in the outcrops examined. The relations of the igneous rocks to each other is very complex and neither this nor their correlations with other districts has been worked out. The occurrence of outcrops of igneous rocks in such numbers probably precludes the possibility of iron formations in most of this township, but lack of exposures and the presence of some positive magnetic attractions west of Pelican river leave this area in doubt so it is mapped as possibly containing Huronian rocks.

While acid rocks are of very common occurrence in the northern half of the township, most of the exposures in the southern part are of basic rocks and usually of the fine grained varieties. The occurrence of sediments interbedded with these rocks is not unusual and work to the south of this township might locate a sedimentary series.

*Magnetic Observations.*—A general discussion of magnetic observations and their significance is given in Chapter IV. Local areas of attraction were found in a few places as indicated on the map. In all cases the attraction is irregular and may be caused by igneous rocks. However, this is not definitely known to be the case. Abnormal dip needle readings as high as  $15^{\circ}$  were obtained in section 7.

*Land Classification.*—A general discussion of the principles of land classification employed in this work is given in Chapter V.

TOWN 36 N., R. 10E.

Survey Made in October, 1914

Under the Direction of  
W. O. HOTCHKISS, State Geologist  
AND  
E. F. BEAN and O. W. WHEELWRIGHT,  
in charge of Field Parties

BY  
O. W. WHEELWRIGHT, Chief of Party  
O. W. POTTER, Asst. Geologist  
HOWARD QUINLAN, Asst. Geologist  
C. S. GWINN, Asst. Geologist

**SYMBOLS AND ABBREVIATIONS.**  
The symbols and abbreviations used on this map are explained in Chapter II.

**TOWN AND RANGE LINES.**  
In constructing this map the south line of the township was laid off as a true east west line. The other boundary lines were then laid off with the lengths shown on the Land Survey plat. Some of the maps are therefore incorrect in shape but this is necessary because definite facts are lacking. The acreage of part of the lots in the north and west tier of sections is shown to give a check on the distances in these sections.

**LOCATIONS.**  
All locations are based on pacing traverses from government land corners. In many cases these were not found and it was necessary to continue the traverse several miles without a check. Locations of certain features may therefore be somewhat wrong. In such cases the feature sought may best be located by its relation to a stream, swamp, lake, or other feature shown on the map.

**PROFILES.**  
The locations of the profiles are shown on the map by dashed blue lines with black letters at the ends. Railroad profiles were furnished by the companies and show elevations of the ground rather than track in most cases; others are from road surveys by the State Highway Commission: most of them are hand level lines made by this Survey. Wherever possible the elevations above sea level are given. These elevations vary from 1050 to 1770 feet. A local datum plane was necessarily assumed in some cases. These cases are identifiable by the fact that the base line is always numbered 0.

**LAND CLASSIFICATION.**  
This is shown on the map by the blue letters. It is explained in the following township description and at length in chapter V.

**MAGNETIC DATA.**  
Dial compass readings are shown in blue figures. Eastward declinations are shown with a dot to the east and westward with a dot to west of the number. Dip needle readings are shown in black. All are positive except those preceded by the negative sign. All readings show deviation of needles from the normal reading of the instrument used. Normal readings are omitted from the map except at each quarter section corner. All abnormal readings are shown.

Traverses were made on lines indicated—usually the N-S section and quarter lines. Dip needle readings were taken each 50 paces, dial compass readings each 100 paces when sun permitted.

Magnetic lines are indicated by heavy black lines, solid where definite and dashed where doubtful.

**CAUTION:** Almost any kind of rock may be the cause of magnetic attraction. Do not fail to read the following description of this township, and also chapter IV., in which the magnetic attractions are discussed.

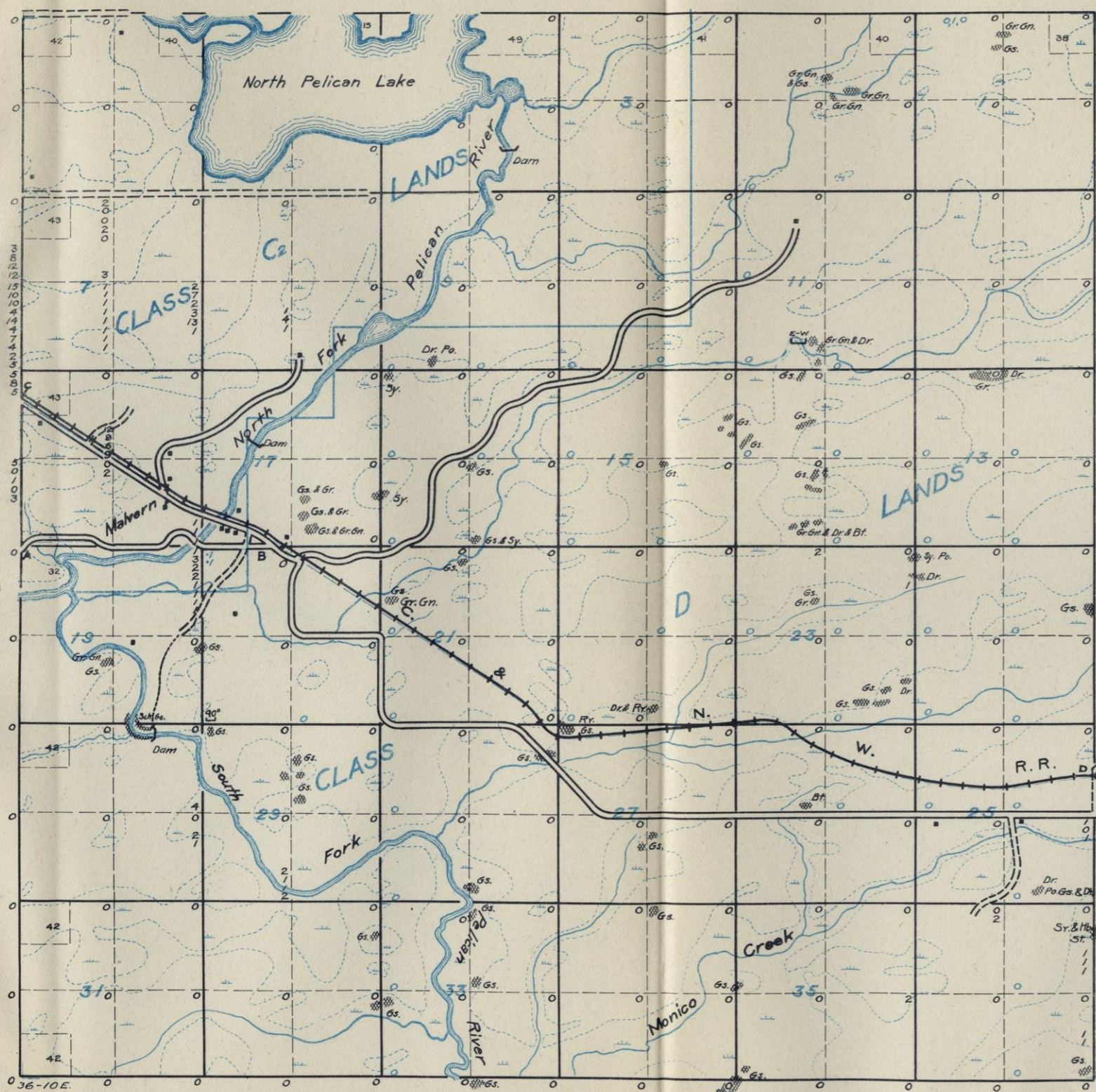

**PROFILES**

VERTICAL SCALE: 1 space = 20'  
HORIZONTAL SCALE: same as map

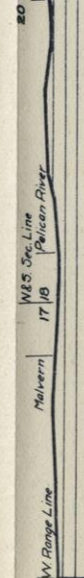
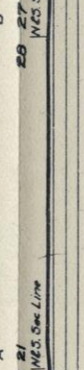
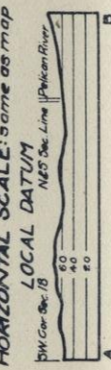

SEA LEVEL DATUM  
1800  
1580  
1560  
1540  
Continued above



Several sections in the **northwestern** part of the township show **magnetic attractions** and **have no** outcrops for which reason they are placed in class C2, **although believed** to be underlain by igneous rocks. All other lands in the township, being quite certainly underlain by igneous rocks, **all placed** in class D.

*Exploration.*—**Exploration in this township** is not recommended. The age and character of the **greenstone** in the southern part is similar to those found in the **iron districts** of Michigan and more geologic work in this general area may show some indications of the presence of iron formation.

## TOWNSHIP 36 N., RANGE 3 E.

*Surface Features.*—This township is characterized by remarkably even surface. The drainage is sluggish and a large part of the surface is swamp. As indicated on the railroad profile, the general elevation above sea level is about 1,650 feet, but is somewhat less on the east side.

The central and southern parts of the township are well settled and are fairly well supplied with roads. Nearly all of the valuable timber has been removed, but small quantities of hardwood and hemlock remain in the southeast quarter of the township and in sections 9 and 10.

*Glacial Drift.*—Except for a very small area on the west side of sections 30 and 31, all the glacial deposits are ground moraine. The drift consists of silt, sand, and gravel, with considerable clay and large quantities of bowlders. The clay occurs more commonly in the eastern half. The west half is more sandy. On the west side of sections 30 and 31 is poorly developed terminal moraine.

There are a large number of wells in the township but none have penetrated to rock. The deepest one recorded is located on section 34 and was sunk to a depth of 63 feet. In the township west wells were sunk to a depth of 160 feet without striking ledge, and it is believed that the drift will likewise be found to be of considerable thickness in this township.

*General Geology.*—Here as in all other townships in this vicinity no rock exposures were found, and there is little evidence upon which to base a statement as to the character of the underlying rocks. It is reported that a well a short distance south of Brantwood in T. 35—3 E. encountered black slate but no samples of the rock were seen. There is little doubt that the slates are of Huronian age. Huronian rocks probably underlie T. 37—3 E. and it is on the basis of this very inconclusive evidence that the township under discussion is assumed to be underlain by rocks of this age.

*Magnetic Observations.*—A general discussion of magnetic observations and their significance is given in chapter IV. In a very few instances mild abnormal attractions were found but their irregular character and distribution is such that they are of no assistance in working out the geology of the township.

*Land Classification.*—A general discussion of the principles of land classification employed in this work is given in Chapter V. All lands

# TOWN 36 N., R. 3E.

Survey Made in July, 1913

Under the Direction of  
**W. O. HOTCHKISS**, State Geologist  
AND  
**E. F. BEAN** and **O. W. WHEELWRIGHT**,  
in charge of Field Parties

BY  
**R. W. CLARK**, Chief of Party  
**W. C. BEAN**, Asst. Geologist  
**E. T. HODGE**, Asst. Geologist

**SYMBOLS AND ABBREVIATIONS.**  
The symbols and abbreviations used on this map are explained in Chapter II.

**TOWN AND RANGE LINES.**  
In constructing this map the south line of the township was laid off as a true east west line. The other boundary lines were then laid off with the lengths shown on the Land Survey plat. Some of the maps are therefore incorrect in shape but this is necessary because definite facts are lacking. The acreage of part of the lots in the north and west tier of sections is shown to give a check on the distances in these sections.

**LOCATIONS.**  
All locations are based on pacing traverses from government land corners. In many cases these were not found and it was necessary to continue the traverse several miles without a check. Locations of certain features may therefore be somewhat wrong. In such cases the feature sought may best be located by its relation to a stream, swamp, lake, or other feature shown on the map.

**PROFILES.**  
The locations of the profiles are shown on the map by dashed blue lines with black letters at the ends. Railroad profiles were furnished by the companies and show elevations of the ground rather than track in most cases; others are from road surveys by the State Highway Commission; most of them are hand level lines made by this Survey. Wherever possible the elevations above sea level are given. These elevations vary from 1050 to 1770 feet. A local datum plane was necessarily assumed in some cases. These cases are identifiable by the fact that the base line is always numbered 0.

**LAND CLASSIFICATION.**  
This is shown on the map by the blue letters. It is explained in the following township description and at length in chapter V.

**MAGNETIC DATA.**  
Dial compass readings are shown in blue figures. Eastward declinations are shown with a dot to the east and westward with a dot to west of the number. Dip needle readings are shown in black. All are positive except those preceded by the negative sign. All readings show deviation of needles from the normal reading of the instrument used. Normal readings are omitted from the map except at each quarter section corner. All abnormal readings are shown.

Traverses were made on lines indicated—usually the N-S section and quarter lines. Dip needle readings were taken each 50 paces, dial compass readings each 100 paces when sun permitted.

Magnetic lines are indicated by heavy black lines, solid where definite and dashed where doubtful.

**CAUTION:** Almost any kind of rock may be the cause of magnetic attraction. Do not fail to read the following description of this township, and also chapter IV., in which the magnetic attractions are discussed.

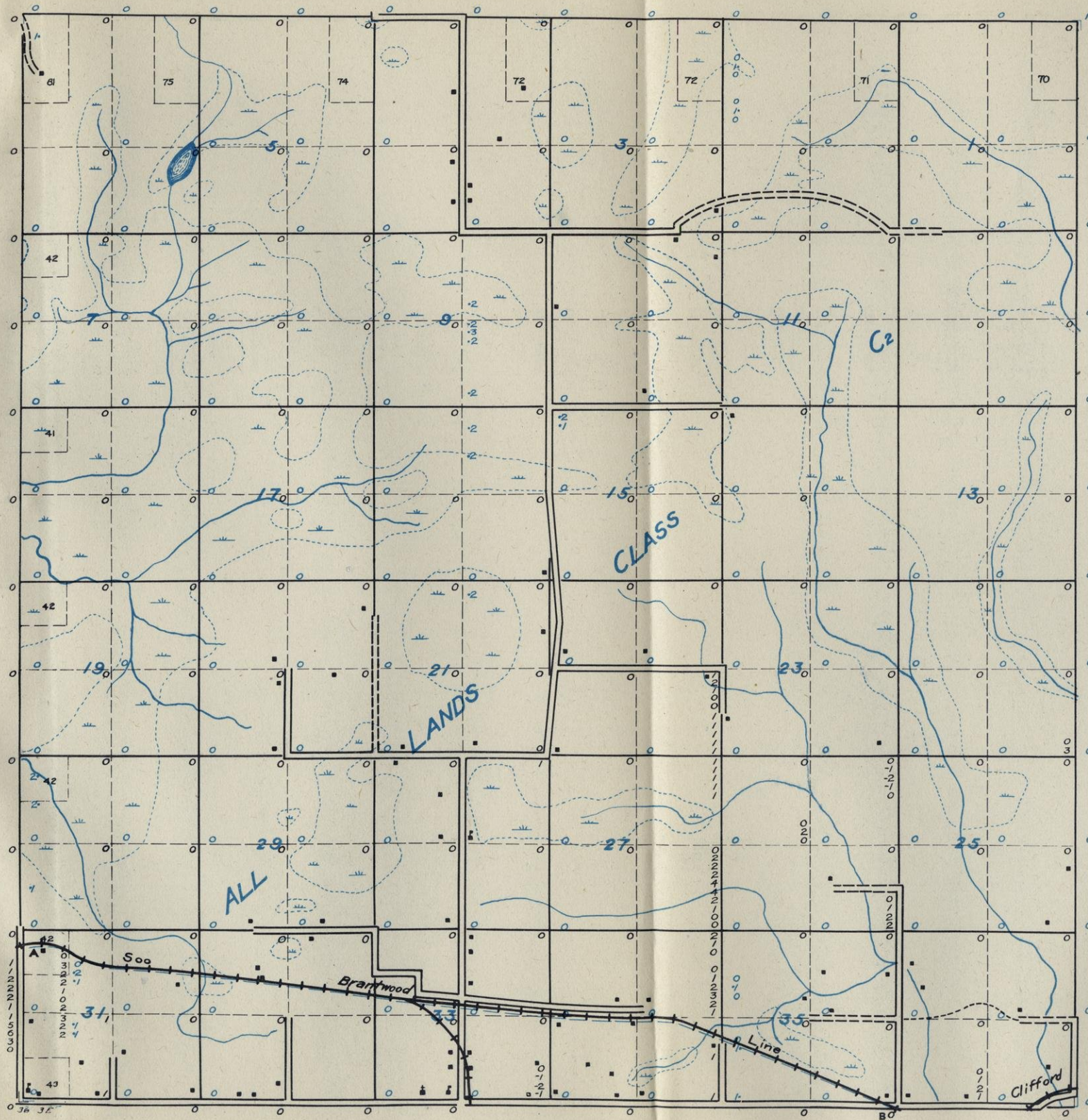

**PROFILE**  
VERTICAL SCALE: 1 space = 20'  
HORIZONTAL SCALE: same as map

SEA LEVEL DATUM

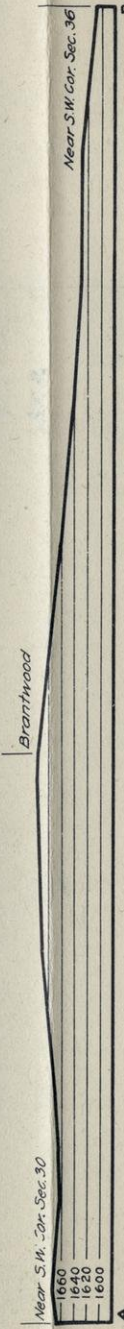

in the township are placed in class C2, for the reasons stated in the paragraph on general geology.

*Exploration.*—Exploration in this township is not recommended at present but additional information from wells may develop facts that will change this view completely.

## TOWNSHIP 36 N., RANGE 2 E.

*Surface Features.*—A gently undulating surface characterizes most of this township. The relief is usually low and the drainage sluggish. A large percentage of the surface is covered with swamps. There are a few areas showing relief of from 25 to 50 feet which appear prominent only because of the monotonous regularity of the surface elsewhere. The largest of these areas occupies that part of the township south of a line from the east quarter post of section 25 to the southwest corner of section 32. Another is found in the north half of sections 4, 5 and 6 and a third is a very small area in the northwest corner of section 18. The south fork of Jump river, which drains most of the area, occupies a broad and very shallow valley.

The profile A-B shows the general level surface of the ground moraine along the west line and the rise in surface as the terminal moraine is reached in section 18. The profile C-D shows the elevation above sea level along the Soo railroad and the rise in elevation in going from the swamp up on the terminal moraine in section 36.

Most of the roads follow section lines and are fairly well graded, but because of the heavy soil are not in the best of shape in wet weather. A belt of hardwood occurs in sections 27, 28, 34, 35 and 36. Other smaller hardwood areas are found in sections 4, 6 and 18, but most of the timber has been cut off.

*Glacial Drift.*—The rougher and more elevated areas mentioned above are terminal moraines of moderate development. The material in the terminal moraines is silt, sand, gravel and bowlders and differs from that in the ground moraine areas because of its more sandy and gravelly nature. The remainder of the township is ground moraine, in which the drift consists of clay, silt, gravel and bowlders, the latter being very numerous in places.

The depth of the drift is not known. There are many wells in the township, several of which are down to a depth of over 100 feet and one was sunk to a depth of 160 feet without reaching ledge. From this it appears that the depth of the drift cover probably exceeds 150 feet in all parts of the township.

*General Geology.*—Rock exposures are entirely lacking and it is impossible to state the character of the underlying rock with any certainty. From the results of the magnetic work and in agreement with conclusions reached for this general area, it is believed that Huronian rocks may underlie the entire township.

TOWN 36 N., R. 2E.

Survey Made in July, 1913

Under the Direction of

W. O. HOTCHKISS, State Geologist

AND

E. F. BEAN and O. W. WHEELWRIGHT,  
in charge of Field Parties

BY

J. C. SCOLES, Chief of Party  
C. OLSON, Asst. Geologist  
F. E. WILLIAMS, Asst. Geologist  
R. C. HANCHETT, Asst. Geologist

SYMBOLS AND ABBREVIATIONS.

The symbols and abbreviations used on this map are explained in Chapter II.

TOWN AND RANGE LINES.

In constructing this map the south line of the township was laid off as a true east west line. The other boundary lines were then laid off with the lengths shown on the Land Survey plat. Some of the maps are therefore incorrect in shape but this is necessary because definite facts are lacking. The acreage of part of the lots in the north and west tier of sections is shown to give a check on the distances in these sections.

LOCATIONS.

All locations are based on pacing traverses from government land corners. In many cases these were not found and it was necessary to continue the traverse several miles without a check. Locations of certain features may therefore be somewhat wrong. In such cases the feature sought may best be located by its relation to a stream, swamp, lake, or other feature shown on the map.

PROFILES.

The locations of the profiles are shown on the map by dashed blue lines with black letters at the ends. Railroad profiles were furnished by the companies and show elevations of the ground rather than track in most cases; others are from road surveys by the State Highway Commission: most of them are hand level lines made by this Survey. Wherever possible the elevations above sea level are given. These elevations vary from 1050 to 1770 feet. A local datum plane was necessarily assumed in some cases. These cases are identifiable by the fact that the base line is always numbered 0.

LAND CLASSIFICATION.

This is shown on the map by the blue letters. It is explained in the following township description and at length in chapter V.

MAGNETIC DATA.

Dial compass readings are shown in blue figures. Eastward declinations are shown with a dot to the east and westward with a dot to west of the number. Dip needle readings are shown in black. All are positive except those preceded by the negative sign. All readings show deviation of needles from the normal reading of the instrument used. Normal readings are omitted from the map except at each quarter section corner. All abnormal readings are shown.

Traverses were made on lines indicated—usually the N-S section and quarter lines. Dip needle readings were taken each 50 paces, dial compass readings each 100 paces when sun permitted.

Magnetic lines are indicated by heavy black lines, solid where definite and dashed where doubtful.

CAUTION: Almost any kind of rock may be the cause of magnetic attraction. Do not fail to read the following description of this township, and also chapter IV., in which the magnetic attractions are discussed.

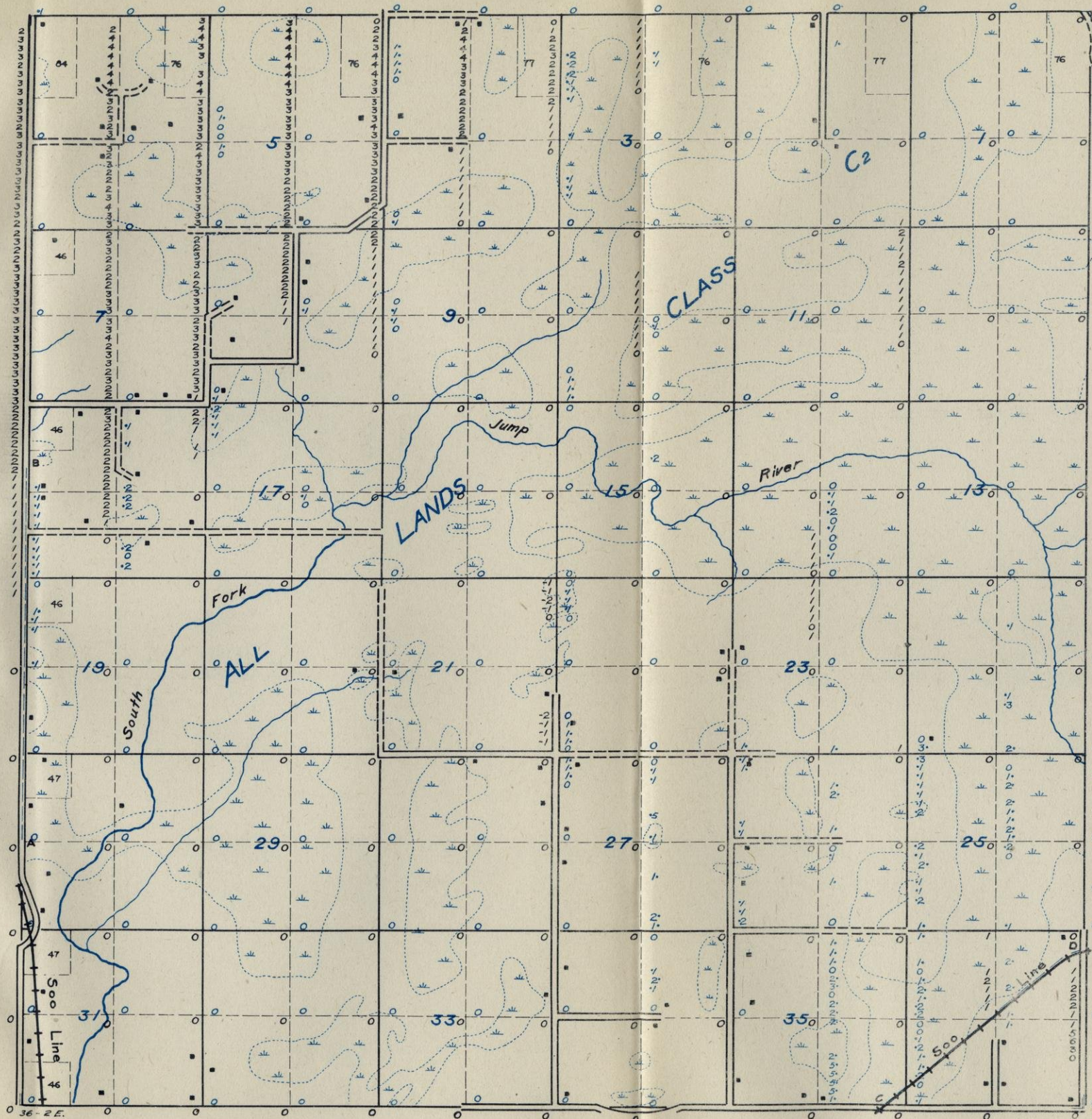

PROFILE  
VERTICAL SCALE: 1 space = 20'  
HORIZONTAL SCALE: same as map

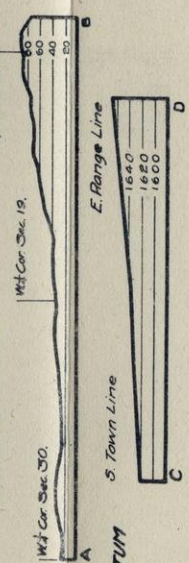

*Magnetic Observations.*—A general discussion of magnetic observations and their significance is given in Chapter IV. Every traverse in the northwestern part of the township shows abnormal dip needle readings ranging from  $1^{\circ}$  to  $4^{\circ}$  but no distinct lines are shown. The attraction is continuous into the township to the north, and it is directly along the strike of a long magnetic line to the northeast. This may be caused either by igneous rocks or by a broad area of sediments.

*Land Classification.*—A general discussion of the principles of land classification employed in this work is given in Chapter V. All lands are placed in Class C2 because there is no definite information upon which to base more detailed classification.

*Exploration.*—Exploration in this township is not recommended until more information on the geology is obtained from wells or other sources. The area cannot be condemned as unlikely to produce iron, but there are no indications to encourage expending money in drilling operations.

## TOWNSHIP 36 N., RANGE 6 W.

*Surface Features.*—This township is flat to gently undulating, the relief being slight even for northern Wisconsin. Bear Creek, Little Thornapple river, and Thornapple river flow in valleys but little below the level of the surrounding country.

There are a few roads in the central and southwestern part of the township but these are not well graded as yet. Except for small areas, the timber has all been cut. There are some farms in the southwest.

*Glacial Drift.*—All of the township is flat to very gently undulating ground moraine with numerous large swamps. In places boulders are numerous. The glacial deposits are largely silt with some boulders. The thickness of glacial drift is not definitely known. The drift cover is probably thin since there is ledge in the central and south central parts of the township, the topography is level, and stream valleys very shallow.

*General Geology.*—Near the center of the township along a north-south wagon road are a number of outcrops of granite. They are usually low and have no topographic expression. The rock varies from a fine-grained, gray hornblende biotite granite, to a rock of similar composition having crystals averaging in about  $\frac{1}{4}$  inch in major dimension. In places pegmatite is intruded in the form of dikes. Through the center of section 3 and at the S.  $\frac{1}{4}$  S. of 28 many large blocks of this granite are found, indicating that the ledge is very close to the surface at this point. These exposures together with the presence of numerous outcrops of granite along the Chipewa river a mile west makes it appear probable that granite underlies the greater part of this township. On the basis of magnetic work it appears that Huronian rocks occupy the eastern third.

*Magnetic Observations.*—A discussion of magnetic observations and their significance is given in chapter IV. Two small areas of mild irregular attractions were found, one in sections 2, 10 and 11, and another in 13. These do not give clean cut magnetic lines and from their character it is judged that they are not caused by a magnetic iron formation. However, they do suggest the presence of Huronian rocks. Rather strong negative attractions were encountered in 29, which are not readily explained but it is believed likely that they are caused by igneous rocks.



**TOWN 36 N., R. 6W.**

Survey Made in August, 1914

Under the Direction of  
**W. O. HOTCHKISS, State Geologist**

AND  
**E. F. BEAN and O. W. WHEELWRIGHT,**  
in charge of Field Parties

BY

**W. I. ROBINSON, Chief of Party**

**S. M. WILLIS, Asst. Geologist**

**G. M. SCHWARTZ, Asst. Geologist**

**SYMBOLS AND ABBREVIATIONS.**

The symbols and abbreviations used on this map are explained in Chapter II.

**TOWN AND RANGE LINES.**

In constructing this map the south line of the township was laid off as a true east west line. The other boundary lines were then laid off with the lengths shown on the Land Survey plat. Some of the maps are therefore incorrect in shape but this is necessary because definite features are lacking. The acreage of part of the lots in the north and west tier of sections is shown to give a check on the distances in these sections.

**LOCATIONS.**

All locations are based on pacing traverses from government land corners. In many cases these were not found and it was necessary to continue the traverse several miles without a check. Locations of certain features may therefore be somewhat wrong. In such cases the feature sought may best be located by its relation to a stream, swamp, lake, or other feature shown on the map.

**PROFILES.**

The locations of the profiles are shown on the map by dashed blue lines with black letters at the ends. Railroad profiles were furnished by the companies and show elevations of the ground rather than track in most cases; others are from road surveys by the State Highway Commission; most of them are hand level lines made by this Survey. Wherever possible the elevations above sea level are given. These elevations vary from 1050 to 1770 feet. A local datum plane was necessarily assumed in some cases. These cases are identifiable by the fact that the base line is always numbered 0.

**LAND CLASSIFICATION.**

This is shown on the map by the blue letters. It is explained in the following township description and at length in chapter V.

**MAGNETIC DATA.**

Dial compass readings are shown in blue figures. Eastward declinations are shown with a dot to the east and westward with a dot to west of the number. Dip needle readings are shown in black. All are positive except those preceded by the negative sign. All readings show deviation of needles from the normal reading of the instrument used. Normal readings are omitted from the map except at each quarter section corner. All abnormal readings are shown.

Traverses were made on lines indicated—usually the N-S section and quarter lines. Dip needle readings were taken each 50 paces, dial compass readings each 100 paces when sun permitted.

Magnetic lines are indicated by heavy black lines, solid where definite and dashed where doubtful.

**CAUTION:** Almost any kind of rock may be the cause of magnetic attraction. Do not fail to read the following description of this township, and also chapter IV., in which the magnetic attractions are discussed.

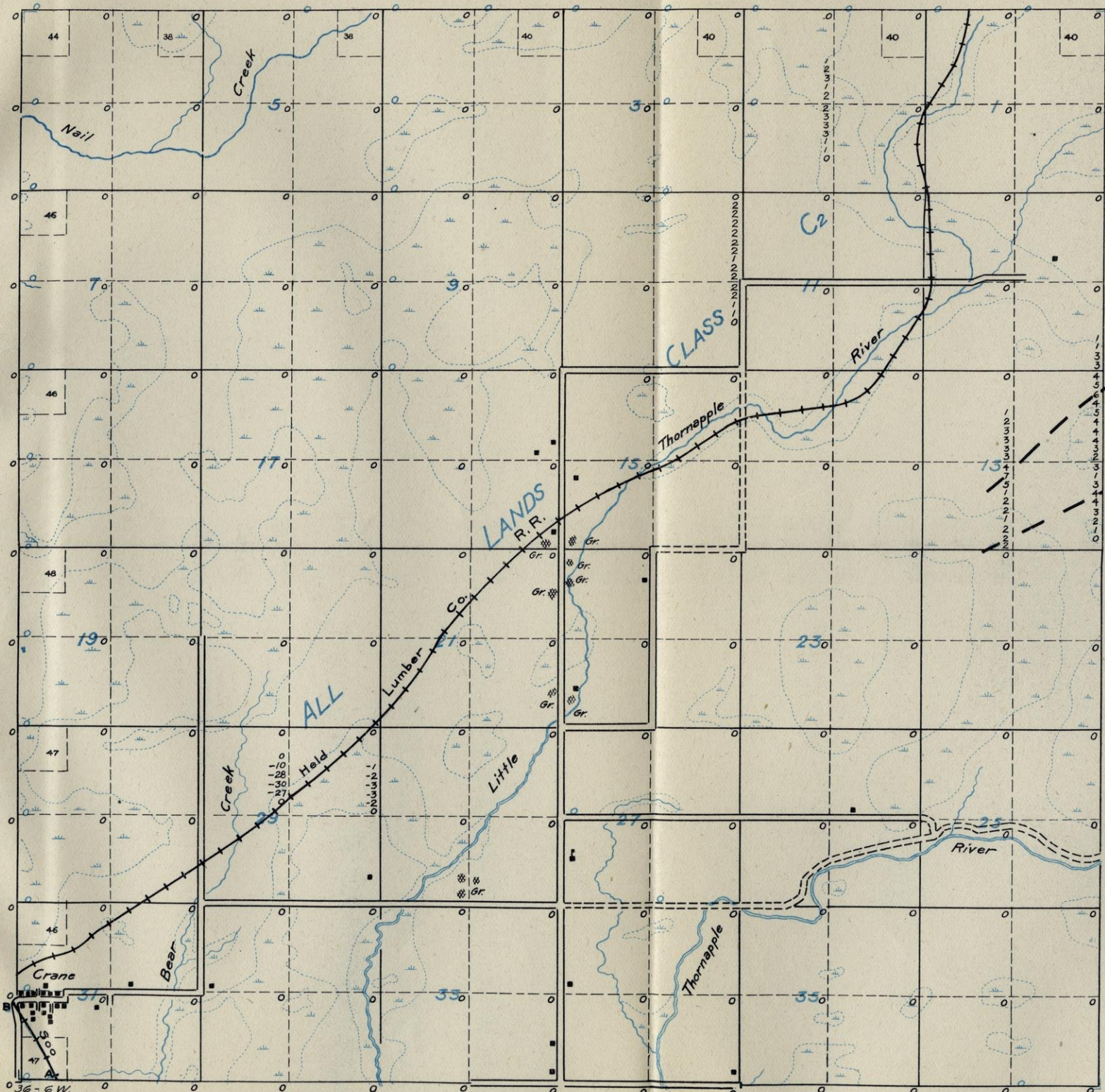

**PROFILE**  
VERTICAL SCALE: 1 space = 20'  
HORIZONTAL SCALE: same as map

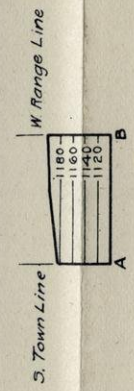

SEA LEVEL DATUM

*Land Classification.*—The principles of land classification employed in this work are discussed in Chapter V. Lands in the immediate vicinity of the granite outcrops are classed as D lands, since they have no prospect for iron ore. All other lands in the township are placed in class C2, although they are not considered as offering much prospect for iron formation. Undoubtedly granite underlies most of the township but since this is not positively known the lands are not placed in class D.

*Exploration.*—As a result of the information obtained by this survey, exploration for iron ore in this township is not to be especially recommended. There is nothing to indicate the presence of iron formation although it is possible that some may occur. Probably the most promising places are the magnetic areas in the north-eastern part.

## TOWNSHIP 36 N., RANGE 7 W.

*Surface Features.*—West of the Chippewa river the topography is rough, due in part to inequalities in the deposition of the glacial drift but in a larger measure to post-glacial erosion of the drift, as well as to pre-glacial erosion in the quartzites underlying the extreme western part of the township. Even the smaller streams have cut deeply into the surface and generally have high steep banks. The quartzite in the western part has a very high and steep escarpment on the east and the flat topped hills slope gently toward the west. At its eastern edge crystalline rocks outcrop in many places, and form a rather gently sloping foothill belt from  $\frac{1}{2}$  to 1 mile wide. Between the C. V. & N. Ry. and the Chippewa the roughness of the topography is due entirely to post-glacial erosion and irregularities in the deposition of the drift. East of the river the surface is generally flat to very gently undulating.

Profile A-B shows the undulating character of the topography east of the Chippewa, the marked valleys cut by this river, the small streams to the west, and the rather abrupt rise of the quartzite near the south quarter post of section 19. Profiles C-D and E-F show the more level, selected routes followed by the Soo railroad and the main wagon road running north and south, a short distance west of the Chippewa river. Both of these latter profiles show the grades of the roads rather than the topography of the country over which they pass.

The roads in this township are generally fairly well graded and are good except in extremely wet weather. No timber remains in the township, recent logging operations having removed the last of the hardwood in the northwestern part. East of the C. V. & N. railroad the original timber, largely pine, was removed many years ago and settlement is progressing rather rapidly in this area.

*Glacial Drift.*—The west half of the township is covered with a thin veneer of ground moraine deposits laid down over a rugged area of pre-Cambrian rocks. These deposits have served to make the topography less rugged than it was before glaciation. A strip about 1 mile wide on either side of the main north and south wagon road is covered with a deposit of dissected outwash. In sections 1 and 2 the outwash is pitted. Nearly all of the area east of the Chippewa river is covered with a fairly level ground moraine. The outwash is composed of silt, sand and gravel, with a few boulders; the ground

moraine of silt, clay and boulders on the west, and of silt, sand and boulders on the east side of the township.

The depth of the drift is usually very moderate as shown by the large number of widely distributed outcrops. The possible exception to this, however, is a strip 2 miles wide lying along the west side of the Chippewa river where the thickness may be as much as 150 feet.

*General Geology.*—This township shows an unusually large number of exposures. One group occurs along the Chippewa river from the Murry bridge north to the township line. All outcrops in this group are low exposures in or near the banks of the river. The rock exposed is chiefly a medium-grained granite having crystals of about  $\frac{1}{4}$  inch in diameter, which has been intruded probably a number of times by dikes of acid rocks varying from an exceedingly fine-grained granite to coarse pegmatites.

Along the front of the Barron quartzite hills, pre-Cambrian igneous rocks are exposed in numerous places as indicated on the map. All are hornblende granite gneiss and their oxidized equivalents, except the few exposures south of the northeast corner of section 17. The latter are highly mashed acid porphyries containing in places large quantities of pyrite.

Along the high bluffs west of these igneous rocks are a number of exposures of quartzite varying in color from a light pink to a dark brick-red, and in texture from very fine grained, well cemented quartzite to conglomerate having pebbles about  $\frac{1}{2}$  inch in diameter. The conglomerate is not of common occurrence and is very thin where found. It is rather well exposed  $\frac{1}{4}$  mile south of the east quarter post of section 8. The pebbles consist principally of quartz but at this point noticeable quantities of iron formation are found in the conglomerate, which appears to indicate that iron formation is located not far distant in the older rocks from which these conglomerates were derived. In a few instances the quartzite was found to be very poorly cemented, in fact almost an unconsolidated sandstone. In all exposures the strike is nearly north and south and the dip west at a low angle. This quartzite belongs to the Barron formation which occurs so commonly to the west of this township.

Rocks of the Huronian series are not exposed but, from evidence obtained in the magnetic work, are believed to be present. The distribution of the different series can best be seen on the map, Plate I.

*Magnetic Observations.*—A general discussion of magnetic observations and their significance is given in Chapter IV. Magnetic attraction was encountered in various places over the township, and while much of it is somewhat irregular in character it follows certain poorly defined lines. A well-defined belt of mild attraction extends from the east line of section 5 southwestward into the next township, where it has been traced for 4 or 5 miles. East of section 5 is a less definite continuation to the western part of section 2 and on into the township to the north. This line of attraction is of sufficiently definite character to indicate that it is caused by an iron formation. The dashed line running from section 2 down into section 20 is somewhat doubtful. A short definite line in section 35 looks as though it might be caused by a sedimentary formation.

*Land Classification.*—For a general discussion of the principles of land classification the reader is referred to Chapter V. In classifying the lands in this township, the Barron quartzite is left out of consideration because as a rule it is not thick enough to interfere with the chances of finding an iron formation beneath. All lands in and near outcrops of the igneous rocks are placed in class D, of no probable value as mineral lands. Lands along the indicated magnetic lines are placed in class C1 but those in sections 3, 4, 5, 6, 7 and 8 are considered more favorably located than the others of this class. All other lands are placed in class C2 because lack of magnetic lines, and doubt as to the character of the rocks underlying, makes more definite classification impossible.

*Exploration.*—The character of the magnetic line in the northwestern part of the township is such as to warrant the belief that it is caused by iron formation and cross-sections of drill holes or test pits across the line are recommended. Probably the most favorable place to drill is in sections 5 and 8 where the line is most definite but the extension to the east is also worthy of some attention. Much of the work done in exploration for iron ore is wasted because of failure to make intelligent use of the geologic and magnetic data to be obtained by a careful preliminary survey, and because the geologic information given by the drill is not properly used as a guide for further work. The value of careful scientific methods of exploration therefore cannot be too strongly emphasized. If exploration is contemplated in this township the discussion of this subject in Chapter VI should be carefully studied.

**TOWN 36 N., R. 7W.**

Survey Made in June, 1914

Under the Direction of  
**W. O. HOTCHKISS**, State Geologist  
AND  
**E. F. BEAN** and **O. W. WHEELWRIGHT**,  
in charge of Field Parties  
BY  
**W. C. BEAN**, Chief of Party  
**GEO. NISHIHARA**, Asst. Geologist  
**HOWARD QUINLAN**, Asst. Geologist

**SYMBOLS AND ABBREVIATIONS.**  
The symbols and abbreviations used on this map are explained in Chapter II.

**TOWN AND RANGE LINES.**  
In constructing this map the south line of the township was laid off as a true east west line. The other boundary lines were then laid off with the lengths shown on the Land Survey plat. Some of the maps are therefore incorrect in shape but this is necessary because definite facts are lacking. The acreage of part of the lots in the north and west tier of sections is shown to give a check on the distances in these sections.

**LOCATIONS.**  
All locations are based on pacing traverses from government land corners. In many cases these were not found and it was necessary to continue the traverse several miles without a check. Locations of certain features may therefore be somewhat wrong. In such cases the feature sought may best be located by its relation to a stream, swamp, lake, or other feature shown on the map.

**PROFILES.**  
The locations of the profiles are shown on the map by dashed blue lines with black letters at the ends. Railroad profiles were furnished by the companies and show elevations of the ground rather than track in most cases; others are from road surveys by the State Highway Commission; most of them are hand level lines made by this Survey. Wherever possible the elevations above sea level are given. These elevations vary from 1050 to 1770 feet. A local datum plane was necessarily assumed in some cases. These cases are identifiable by the fact that the base line is always numbered 0.

**LAND CLASSIFICATION.**  
This is shown on the map by the blue letters. It is explained in the following township description and at length in chapter V.

**MAGNETIC DATA.**  
Dial compass readings are shown in blue figures. Eastward declinations are shown with a dot to the east and westward with a dot to the west of the number. Dip needle readings are shown in black. All are positive except those preceded by the negative sign. All readings show deviation of needles from the normal reading of the instrument used. Normal readings are omitted from the map except at each quarter section corner. All abnormal readings are shown.

Traverses were made on lines indicated—usually the N-S section and quarter lines. Dip needle readings were taken each 50 paces, dial compass readings each 100 paces when sun permitted.

Magnetic lines are indicated by heavy black lines, solid where definite and dashed where doubtful.

**CAUTION:** Almost any kind of rock may be the cause of magnetic attraction. Do not fail to read the following description of this township, and also chapter IV., in which the magnetic attractions are discussed.

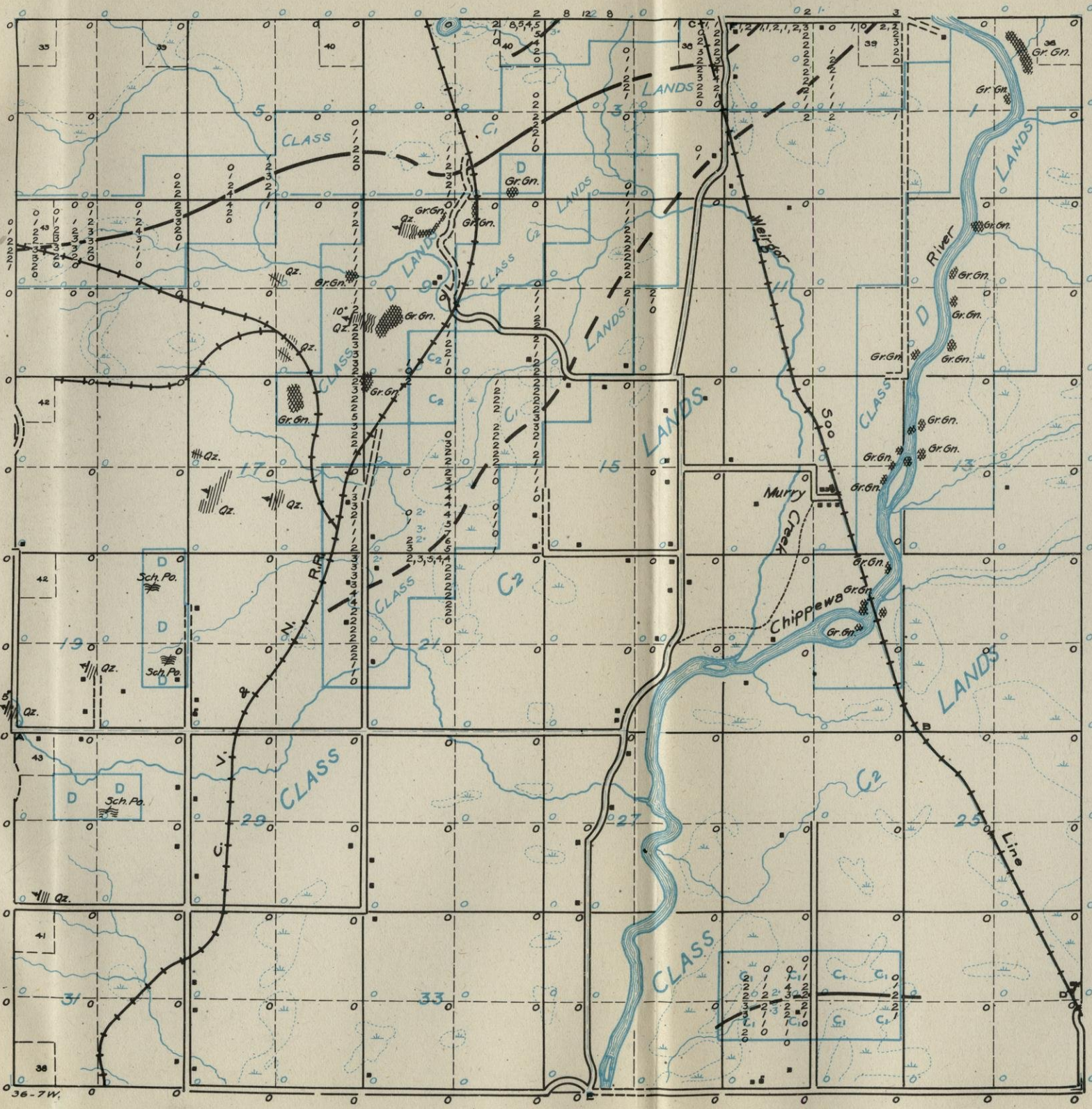

**PROFILES**  
VERTICAL SCALE: 1 space = 20'  
HORIZONTAL SCALE: same as map

**SEA LEVEL DATUM**

SW Cor. Sec. 19  
SW Cor. Sec. 20  
Little Weinger Creek  
SW Cor. Sec. 21  
Little Weinger Creek  
SW Cor. Sec. 22  
Chippewa River  
SW Cor. Sec. 23  
SW RR  
SW Cor. Sec. 24

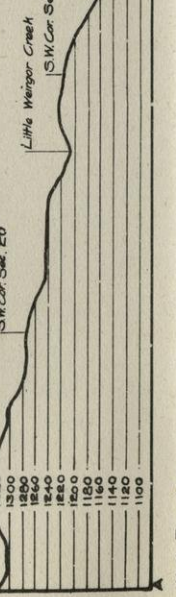

North Town Line  
Chippewa River Bridge  
Chippewa River  
Murry Road  
Arpa Road to Camp 9  
Weinger Creek

SW Cor. Sec. 34  
SW Cor. Sec. 35  
SW Cor. Sec. 36  
SW Cor. Sec. 37  
SW Cor. Sec. 38  
SW Cor. Sec. 39  
SW Cor. Sec. 40

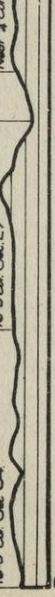

Continued below

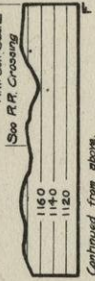

Continued from above

## TOWNSHIP 36 N., RANGE 8 W.

*Surface Features.*—Except along the stream courses the eastern part of the township is level to gently undulating. The western portion is roughly undulating. The valley of Weirgor creek is the most striking feature of the township. This valley was undoubtedly cut in the quartzite in pre-glacial times.

The road from the southeastern corner of section 13 to Weirgor creek is newly built and not well graded. The extension of this road to the west range line is cut out but not graded.

Some timber remains in the central and eastern portion. At present there are but four settlers in the township, but the eastern portion will eventually support a good agricultural population.

*Glacial Drift.*—The western part of the township is roughly undulating terminal moraine. The central and eastern portion is gently undulating ground moraine. The glacial deposits are sand, gravel, and silt with numerous bowlders in the terminal moraine; silt, some sand and bowlders in the ground moraine.

The thickness of the drift is not known as no wells penetrate to rock. The numerous rock outcrops and broad flat uplands in the eastern part of the township indicate that the underlying rock controls the topography and that the glacial drift is but a thin veneer, probably averaging less than 50 feet in thickness. The relief in the western part probably indicates a greater thickness.

*General Geology.*—The Barron formation is found widely distributed over the township. In all cases the rock is the fine-grained pink quartzite typical of this formation. In all except one exposure it strikes about N. 65° E. and dips from 5° to 10° northwest. The outcrop at the N.  $\frac{1}{4}$  S. of 5 strikes N. 28° E. and dips west at a 5° angle. Undoubtedly most of the township is underlain by this rock. How thick it may be in the western part is impossible to state but the evidence obtained from the study of the formation as a whole favors the belief that it is not more than a few hundred feet at most. This question is discussed fully in that part of Chapter III devoted to the Barron formation.

Near the southwest corner of section 36 streams have eroded through the quartzite and exposed the underlying older rocks which here consist of very fine-grained schistose greenstone. Along Weirgor creek in the east side of section 10 there is found a large

exposure of similar rock. This type of rock is of common occurrence in the iron districts of northeastern Wisconsin and Michigan and its presence here is considered as an indication of the presence of Huronian rocks which may contain iron formation.

*Magnetic Observations.*—A discussion of magnetic observations and their significance is given in Chapter IV. A well-defined line of mild attraction has been traced from the east line of section 12 southwesterly to the S.  $\frac{1}{4}$  S. of 9. It is continuous for several miles in the township east. The attraction was found on all traverses which crossed the line. Although the greenstone in section 10 lies only  $\frac{1}{4}$  mile north of the maximum readings along this line, it is not probable that this rock is the cause of the attraction. The line is well defined and so persistent over a long distance that it strongly suggests mildly magnetic iron formation.

*Land Classification.*—The principles of land classification employed in this work are discussed in Chapter V. All lands along the above mentioned magnetic line are classed as C1, and are believed to be underlain by iron formation. Elsewhere in the township the lands are classed as C2. The quartzite has not been taken into consideration in this classification since it is not thought to be thick over the older rocks.

*Exploration.*—A reasonable amount of work along the magnetic line is warranted. A cross section of test pits or drill holes should be made over the magnetic area to definitely establish the cause of the attraction. How far the work should be carried will depend entirely on the character of the rock encountered. Much of the work done in exploration for iron ore is wasted because of failure to make intelligent use of the geologic and magnetic data to be obtained by a careful preliminary survey, and because the geologic information given by the drill is not properly used as a guide for further work. The value of careful scientific methods of exploration therefore cannot be too strongly emphasized. If exploration is contemplated in this township the discussion of this subject in Chapter VI should be carefully studied.



# TOWN 36 N., R. 8W.

Survey Made in August, 1914

Under the Direction of  
**W. O. HOTCHKISS**, State Geologist  
AND  
**E. F. BEAN** and **O. W. WHEELWRIGHT**,  
in charge of Field Parties

BY  
**LOUIS ROARK**, Chief of Party  
**G. M. EHLERS**, Asst. Geologist  
**GEO. BELCHIC**, Asst. Geologist

**SYMBOLS AND ABBREVIATIONS.**  
The symbols and abbreviations used on this map are explained in Chapter II.

**TOWN AND RANGE LINES.**  
In constructing this map the south line of the township was laid off as a true east west line. The other boundary lines were then laid off with the lengths shown on the Land Survey plat. Some of the maps are therefore incorrect in shape but this is necessary because definite facts are lacking. The acreage of part of the lots in the north and west tier of sections is shown to give a check on the distances in these sections.

**LOCATIONS.**  
All locations are based on pacing traverses from government land corners. In many cases these were not found and it was necessary to continue the traverse several miles without a check. Locations of certain features may therefore be somewhat wrong. In such cases the feature sought may best be located by its relation to a stream, swamp, lake, or other feature shown on the map.

**PROFILES.**  
The locations of the profiles are shown on the map by dashed blue lines with black letters at the ends. Railroad profiles were furnished by the companies and show elevations of the ground rather than track in most cases; others are from road surveys by the State Highway Commission: most of them are hand level lines made by this Survey. Wherever possible the elevations above sea level are given. These elevations vary from 1050 to 1770 feet. A local datum plane was necessarily assumed in some cases. These cases are identifiable by the fact that the base line is always numbered 0.

**LAND CLASSIFICATION.**  
This is shown on the map by the blue letters. It is explained in the following township description and at length in chapter V.

**MAGNETIC DATA.**  
Dial compass readings are shown in blue figures. Eastward declinations are shown with a dot to the east and westward with a dot to west of the number. Dip needle readings are shown in black. All are positive except those preceded by the negative sign. All readings show deviation of needles from the normal reading of the instrument used. Normal readings are omitted from the map except at each quarter section corner. All abnormal readings are shown.

Traverses were made on lines indicated—usually the N-S section and quarter lines. Dip needle readings were taken each 50 paces, dial compass readings each 100 paces when sun permitted.

Magnetic lines are indicated by heavy black lines, solid where definite and dashed where doubtful.

**CAUTION:** Almost any kind of rock may be the cause of magnetic attraction. Do not fail to read the following description of this township, and also chapter IV., in which the magnetic attractions are discussed.

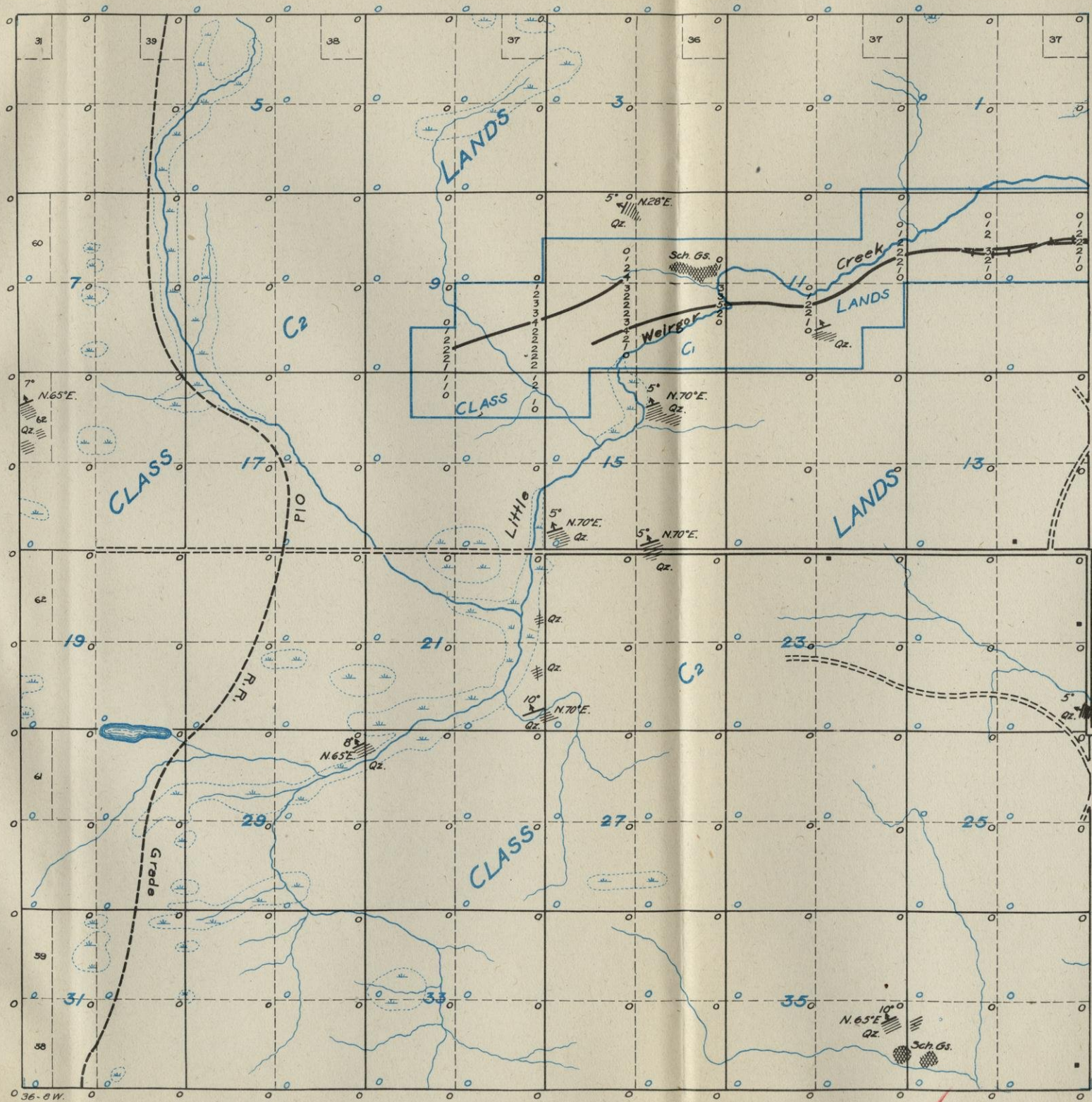

## TOWNSHIP' 36 N., RANGE 9 W.

*Surface Features.*—This township is characterized by extremely rough topography, the result of pre-glacial erosion and glacial deposition. As shown by the road profiles, the maximum relief in the township amounts to 220 feet, which is rather unusual in this section of the country. Much of the ruggedness in the surface is due to the Barron quartzite which was deeply eroded previous to the advance of the glaciers. Frequently the valleys are miniature canyons with nearly vertical walls as much as 75 feet high. In the southern part of the township and in parts of sections 4 and 5 the topography is of the knob and basin type and the effects of the quartzite are less apparent.

Roads are found only in the northwestern part and while gradually being improved they are yet in poor condition. Most of the timber has been removed and recently settlement has been progressing rapidly in the northwestern part.

*Glacial Drift.*—Because of the effect of the Barron quartzite on the topography, the glacial geology of this township is not very clear. South of the Hemlock river is a rugged area of terminal moraine characterized by knobs and depressions, many of which are filled with small lakes. North of this is a broad valley covered by ground moraine deposits. On the north side of this valley there appears a ridge of Barron quartzite which outcrops in a number of places along the slope of the hills. North of this quartzite ridge is an area of high undulating ground, the contour of which is largely controlled by the rock. It is deeply dissected by streams, and in places presents terminal moraine characteristics, but usually has the appearance of ground moraine. This area includes sections 1, 2, 3, 10, 11, 12, 13, 14, 15 and 16, the S. E.  $\frac{1}{4}$  of 17, the S. E.  $\frac{1}{4}$  of 18, and sections 19 to 24. Northwest of an irregular line drawn from the north quarter post of 3, to the southwest corner of 18, is an area on which the effect of rock control is not noticeable. It appears likely that the quartzite is absent here. This area is rugged, but is characteristic of ground moraine rather than of terminal except in the east side of section 5 and the north half of section 4, where a pronounced terminal moraine is found which extends into the township to the north.

The glacial deposits are composed of silt, sand, gravel and bowlders. Sandy areas are not of common occurrence, however. Large bowlders are numerous over most of the township.

As a rule the drift is not deep **except in the northwest corner and in the south tier of sections.** In these the depth may reach as much as 200 feet, but elsewhere it is probably less than 100 feet.

*General Geology.*—This township, with the exception of the part southwest of Pigeon river is known to be underlain by the Barron quartzite. It outcrops in a number of places throughout the township, but the exposures usually consist of talus slopes, which show no rock in position. The quartzite is a well cemented quartz sand varying in color from a brick red to a light pink and white stain-banded rock. Seams of pipe stone are of frequent occurrence. Where exposed in place the strike is nearly north and south, and the dip is very gently to the west. The greatest thickness exposed is about 75 feet and it is not probable that the thickness in any part of the township is greater than 200 or 250 feet. The quartzite is believed to have been eroded away almost completely in the area northwest of Pigeon river. Huronian rocks probably underlie this formation but of their character nothing is known. Two diamond drill holes were recently put down in the N. E.  $\frac{1}{4}$  of section 18, and may have penetrated the Huronian rocks but nothing is known of the character of the formations encountered. One of the holes was drilled to a depth of 125 feet.

*Magnetic Observations.*—No abnormal magnetic attraction was found in this township.

*Land Classification.*—For a thorough understanding of the principles of land classification employed in this work the reader is referred to Chapter V. The Barron quartzite is a non-productive formation, but believing that it covers the township only as a thin mantle, it is not taken into consideration when making the classification of lands. There is a possibility that the older rocks beneath may contain Huronian sediments and therefore all lands are placed in class C2.

*Exploration.*—Since the results of this survey give no idea whatever of the character of the pre-Cambrian rocks, exploration in this township cannot be recommended. This does not mean that iron formation may not occur but simply that there are no indications of its presence and consequently exploration offers little chance of reward.

TOWN 36 N., R. 9W.

Survey Made in June, 1914

Under the Direction of  
W. O. HOTCHKISS, State Geologist  
AND  
E. F. BEAN and O. W. WHEELWRIGHT,  
in charge of Field Parties

BY  
R. W. CLARK, Chief of Party  
J. R. ROBERTS, Asst. Geologist  
W. G. CRAWFORD, Asst. Geologist

**SYMBOLS AND ABBREVIATIONS.**  
The symbols and abbreviations used on this map are explained in Chapter II.

**TOWN AND RANGE LINES.**  
In constructing this map the south line of the township was laid off as a true east west line. The other boundary lines were then laid off with the lengths shown on the Land Survey plat. Some of the maps are therefore incorrect in shape but this is necessary because definite facts are lacking. The acreage of part of the lots in the north and west tier of sections is shown to give a check on the distances in these sections.

**LOCATIONS.**  
All locations are based on pacing traverses from government land corners. In many cases these were not found and it was necessary to continue the traverse several miles without a check. Locations of certain features may therefore be somewhat wrong. In such cases the feature sought may best be located by its relation to a stream, swamp, lake, or other feature shown on the map.

**PROFILES.**  
The locations of the profiles are shown on the map by dashed blue lines with black letters at the ends. Railroad profiles were furnished by the companies and show elevations of the ground rather than track in most cases; others are from road surveys by the State Highway Commission: most of them are hand level lines made by this Survey. Wherever possible the elevations above sea level are given. These elevations vary from 1050 to 1770 feet. A local datum plane was necessarily assumed in some cases. These cases are identifiable by the fact that the base line is always numbered 0.

**LAND CLASSIFICATION.**  
This is shown on the map by the blue letters. It is explained in the following township description and at length in chapter V.

**MAGNETIC DATA.**  
Dial compass readings are shown in blue figures. Eastward declinations are shown with a dot to the east and westward with a dot to west of the number. Dip needle readings are shown in black. All are positive except those preceded by the negative sign. All readings show deviation of needles from the normal reading of the instrument used. Normal readings are omitted from the map except at each quarter section corner. All abnormal readings are shown.

Traverses were made on lines indicated—usually the N-S section and quarter lines. Dip needle readings were taken each 50 paces, dial compass readings each 100 paces when sun permitted.

Magnetic lines are indicated by heavy black lines, solid where definite and dashed where doubtful.

**CAUTION:** Almost any kind of rock may be the cause of magnetic attraction. Do not fail to read the following description of this township, and also chapter IV., in which the magnetic attractions are discussed.

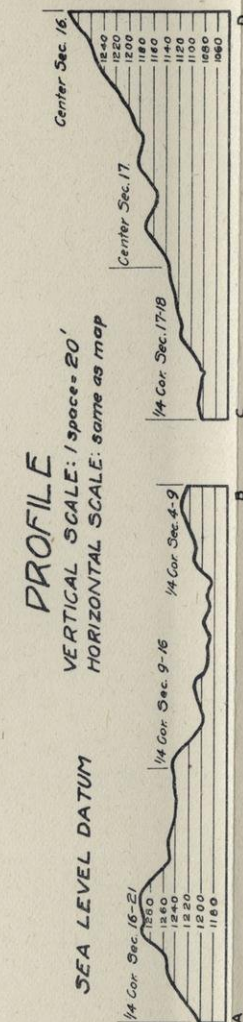
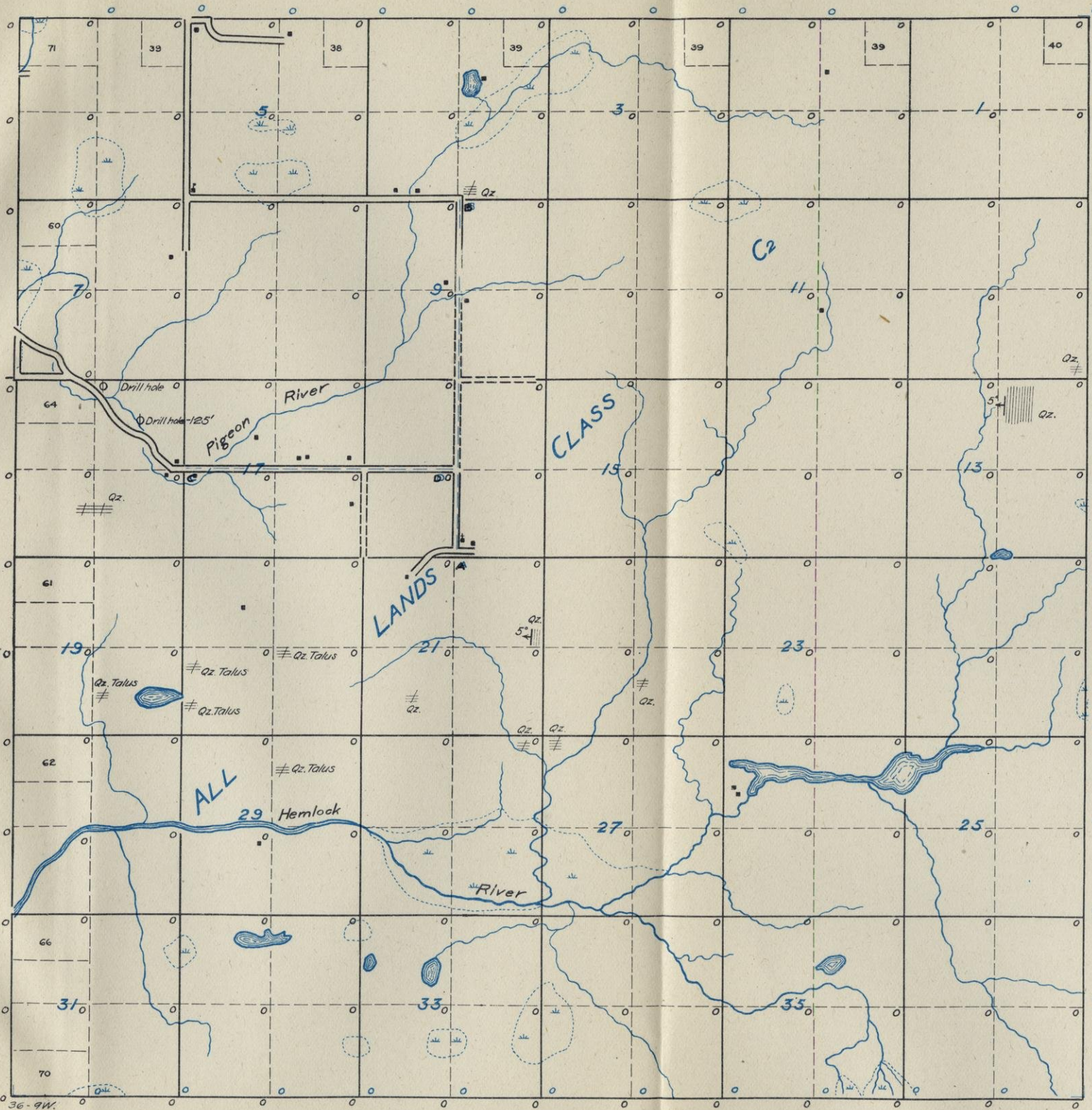

## TOWNSHIP 36 N., RANGE 10 W.

*Surface Features.*—The **northeastern** part of this township is gently undulating, and the **southwestern** part is a flat plain. Between these areas is a gently to roughly undulating region. Red Cedar Lake, over 4 miles in **length**, is the most striking feature of the township. It probably occupies a pre-glacial valley which was blocked by glacial deposits.

The accompanying profiles show elevations ranging from 1160 feet above sea level along Red Cedar Lake in section 31 to 1,285 feet above sea level in the north of section 8.

Most of the roads west of Red Cedar Lake are good. The main traveled road is the one running north and south through the center of the township. Along the borders of Red Cedar Lake and in small areas in the terminal moraine there is some hardwood. Well improved farms are numerous west of Red Cedar and Hemlock lakes.

*Glacial Drift.*—In the northeast is an area of gently undulating ground moraine. In the southwest is a belt of level outwash. Between these is a terminal moraine, the eastern part of which is of high relief with hills suggesting the influence of rock topography, while the western part is gently to roughly undulating with depressions occupied by swamps and small lakes.

The glacial deposits are sand and silt in the outwash areas; silt, some sand, and boulders in the ground moraine; silt, sand, gravel and boulders in the terminal moraine.

The thickness of the drift in the southeastern part of the township is not definitely known, but the abundance of angular quartzite boulders would indicate that the covering is thin. Ledge is reported at a depth of 100 feet in a well in section 9. It seems probable that drift cover in the western portion of the township is somewhat thicker than it is in the eastern portion.

*General Geology.*—Quartzite talus is found near the northeastern corner and N.  $\frac{1}{4}$  S. of section 25. It appears quite probable that the Barron quartzite underlies the extreme southeastern part of the township. Sandstone, probably of Cambrian age, is thought to underlie all of the remainder. It was found at a depth of 100 feet in a well near the W.  $\frac{1}{4}$  S. of 9. Wells also show this sandstone in section 33 of the township to the north. Of the older rocks beneath the Cambrian and Barron formations nothing is known but there is

a possibility that Huronian rocks will be found at no very great depth. These may contain iron formation.

*Magnetic Observations.*—No abnormal magnetic attraction was found in this township.

*Land Classification.*—The general principles of land classification employed in this work are discussed in Chapter V. All lands in this township are placed in class C2, for the reason that nothing is known of the character of the older rocks underneath the sandstone and quartzite. As usual the sandstone and quartzite are not taken into consideration in making the classification.

*Exploration.*—Because of the entire lack of information on the character of the older rocks in this township, no exploration is recommended. The possibility of the existence of iron formation is recognized but there is nothing to indicate where it may be found.

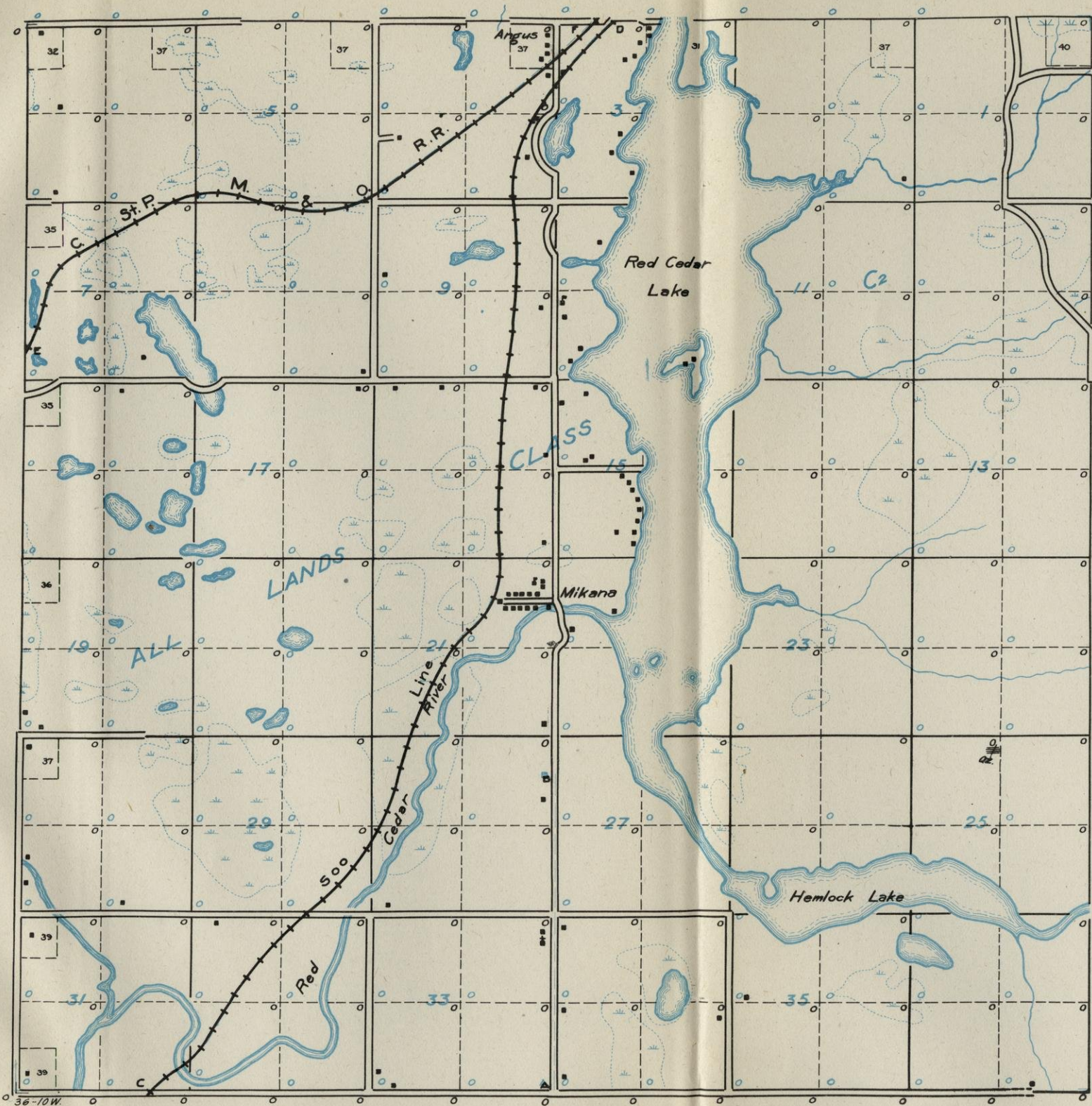

**PROFILES**  
 VERTICAL SCALE: 1 space = 20'  
 HORIZONTAL SCALE: same as map

SEA LEVEL DATUM

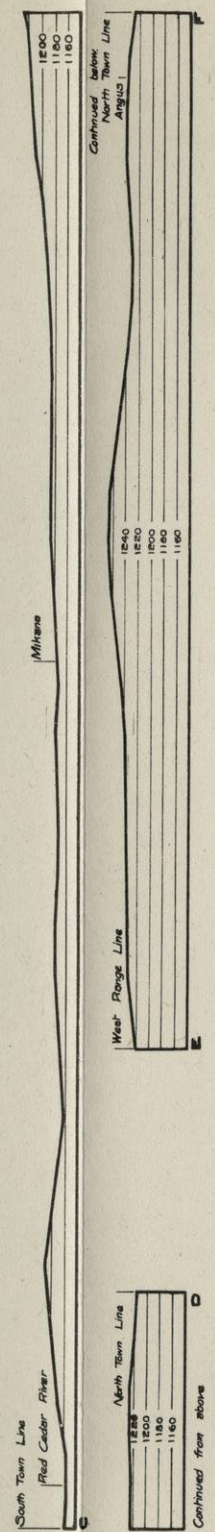

**TOWN 36 N., R. 10 W.**

Survey Made in July, 1914

Under the Direction of  
 W. O. HOTCHKISS, State Geologist

AND  
 E. F. BEAN and O. W. WHEELWRIGHT,  
 in charge of Field Parties

BY  
 W. I. ROBINSON, Chief of Party

S. M. WILLIS, Asst. Geologist

G. M. SCHWARTZ, Asst. Geologist

**SYMBOLS AND ABBREVIATIONS.**

The symbols and abbreviations used on this map are explained in Chapter II.

**TOWN AND RANGE LINES.**

In constructing this map the south line of the township was laid off as a true east west line. The other boundary lines were then laid off with the lengths shown on the Land Survey plat. Some of the maps are therefore incorrect in shape but this is necessary because definite facts are lacking. The acreage of part of the lots in the north and west tier of sections is shown to give a check on the distances in these sections.

**LOCATIONS.**

All locations are based on pacing traverses from government land corners. In many cases these were not found and it was necessary to continue the traverse several miles without a check. Locations of certain features may therefore be somewhat wrong. In such cases the feature sought may best be located by its relation to a stream, swamp, lake, or other feature shown on the map.

**PROFILES.**

The locations of the profiles are shown on the map by dashed blue lines with black letters at the ends. Railroad profiles were furnished by the companies and show elevations of the ground rather than track in most cases; others are from road surveys by the State Highway Commission: most of them are hand level lines made by this Survey. Wherever possible the elevations above sea level are given. These elevations vary from 1050 to 1770 feet. A local datum plane was necessarily assumed in some cases. These cases are identifiable by the fact that the base line is always numbered 0.

**LAND CLASSIFICATION.**

This is shown on the map by the blue letters. It is explained in the following township description and at length in chapter V.

**MAGNETIC DATA.**

Dial compass readings are shown in blue figures. Eastward declinations are shown with a dot to the east and westward with a dot to west of the number. Dip needle readings are shown in black. All are positive except those preceded by the negative sign. All readings show deviation of needles from the normal reading of the instrument used. Normal readings are omitted from the map except at each quarter section corner. All abnormal readings are shown.

Traverses were made on lines indicated—usually the N-S section and quarter lines. Dip needle readings were taken each 50 paces, dial compass readings each 100 paces when sun permitted.

Magnetic lines are indicated by heavy black lines, solid where definite and dashed where doubtful.

**CAUTION:** Almost any kind of rock may be the cause of magnetic attraction. Do not fail to read the following description of this township, and also chapter IV., in which the magnetic attractions are discussed.

## TOWNSHIP 37 N., RANGE 4 E.

*Surface Features.*—Only the northern third of this township is treated in this report, since the remainder was not surveyed. Most of the surface is nearly level, but three areas of rough ground are found. A ridge about  $\frac{1}{4}$  mile wide extends from the northeast corner of section 5 to the south quarter post of section 8. Another of varying width extends north and south over the east half of sections 2 and 11, and the area between Willow Lake and Long Lake is also rugged. Most of the flatter portions are swampy.

One very poor road from Hazelhurst enters the township in the lake region in sections 3 and 4 where there is a saw mill. The timber which is largely hemlock and hardwood remains uncut in sections 3, 4, 5, 6, 7, 8, and 9. The swamps in this portion of the township also contain some cedar, spruce and tamarack.

*Glacial Drift.*—The rougher areas mentioned above are terminal moraine deposits. A small amount of outwash occurs in the southern part of section 9. The remainder of the drift is ground moraine. All of the drift consists of sand, gravel and boulders, the surface being characteristically rather sandy. The small outwash area in section 9 is relatively free from boulders.

The depth of the drift is unknown although it will probably prove to be great in all that part of the township surveyed.

*General Geology.*—No outcrops were found, and there is no direct information bearing on the character of the underlying rocks but from the magnetic attraction it is believed that they are probably of Huronian age.

*Magnetic Observations.*—A general discussion of magnetic observations and their significance is given in Chapter IV. The well defined line of attraction crossing T. 37-3 E. extends through section 6. Its character here is, however, such as not to attract attention were it not for the fact that it is so continuous in the adjoining township. It is not unlikely that this marks the location of an iron formation. Very slight attractions were found at other points, but none of them form well defined lines.

*Land Classification.*—A general discussion of the principles of land classification employed in this work is given in Chapter V. Lands on the magnetic line in section 6 are placed in class C1, and all others in C2.



*Exploration.*—Exploration in this township should be confined to the magnetic line of section 6. It is believed that some work should be done on this line to determine the cause of the attraction. Results at any one place will indicate whether further work is likely to lead to the discovery of ore. Much of the work done in exploration for iron ore is wasted because of failure to make intelligent use of the geologic and magnetic data to be obtained by a careful preliminary survey, and because the geologic information given by the drill is not properly used as a guide for further work. The value of careful scientific methods of exploration therefore cannot be too strongly emphasized. If exploration is contemplated in this township the discussion of this subject in Chapter VI should be carefully studied.

### TOWN 37 N., R. 4E.

Survey Made in September, 1913

Under the Direction of  
W. O. HOTCHKISS, State Geologist  
AND  
E. F. BEAN and O. W. WHEELWRIGHT,  
in charge of Field Parties

BY  
H. H. BRADT, Chief of Party  
J. O. BRYANT, Asst. Geologist  
W. L. DOBIE, Asst. Geologist

#### SYMBOLS AND ABBREVIATIONS.

The symbols and abbreviations used on this map are explained in Chapter II.

#### TOWN AND RANGE LINES.

In constructing this map the south line of the township was laid off as a true east west line. The other boundary lines were then laid off with the lengths shown on the Land Survey plat. Some of the maps are therefore incorrect in shape but this is necessary because definite facts are lacking. The acreage of part of the lots in the north and west tier of sections is shown to give a check on the distances in these sections.

#### LOCATIONS.

All locations are based on pacing traverses from government land corners. In many cases these were not found and it was necessary to continue the traverse several miles without a check. Locations of certain features may therefore be somewhat wrong. In such cases the feature sought may best be located by its relation to a stream, swamp, lake, or other feature shown on the map.

#### PROFILES.

The locations of the profiles are shown on the map by dashed blue lines with black letters at the ends. Railroad profiles were furnished by the companies and show elevations of the ground rather than track in most cases; others are from road surveys by the State Highway Commission: most of them are hand level lines made by this Survey. Wherever possible the elevations above sea level are given. These elevations vary from 1050 to 1770 feet. A local datum plane was necessarily assumed in some cases. These cases are identifiable by the fact that the base line is always numbered 0.

#### LAND CLASSIFICATION.

This is shown on the map by the blue letters. It is explained in the following township description and at length in chapter V.

#### MAGNETIC DATA.

Dial compass readings are shown in blue figures. Eastward declinations are shown with a dot to the east and westward with a dot to west of the number. Dip needle readings are shown in black. All are positive except those preceded by the negative sign. All readings show deviation of needles from the normal reading of the instrument used. Normal readings are omitted from the map except at each quarter section corner. All abnormal readings are shown.

Traverses were made on lines indicated—usually the N-S section and quarter lines. Dip needle readings were taken each 50 paces, dial compass readings each 100 paces when sun permitted.

Magnetic lines are indicated by heavy black lines, solid where definite and dashed where doubtful.

CAUTION: Almost any kind of rock may be the cause of magnetic attraction. Do not fail to read the following description of this township, and also chapter IV., in which the magnetic attractions are discussed.

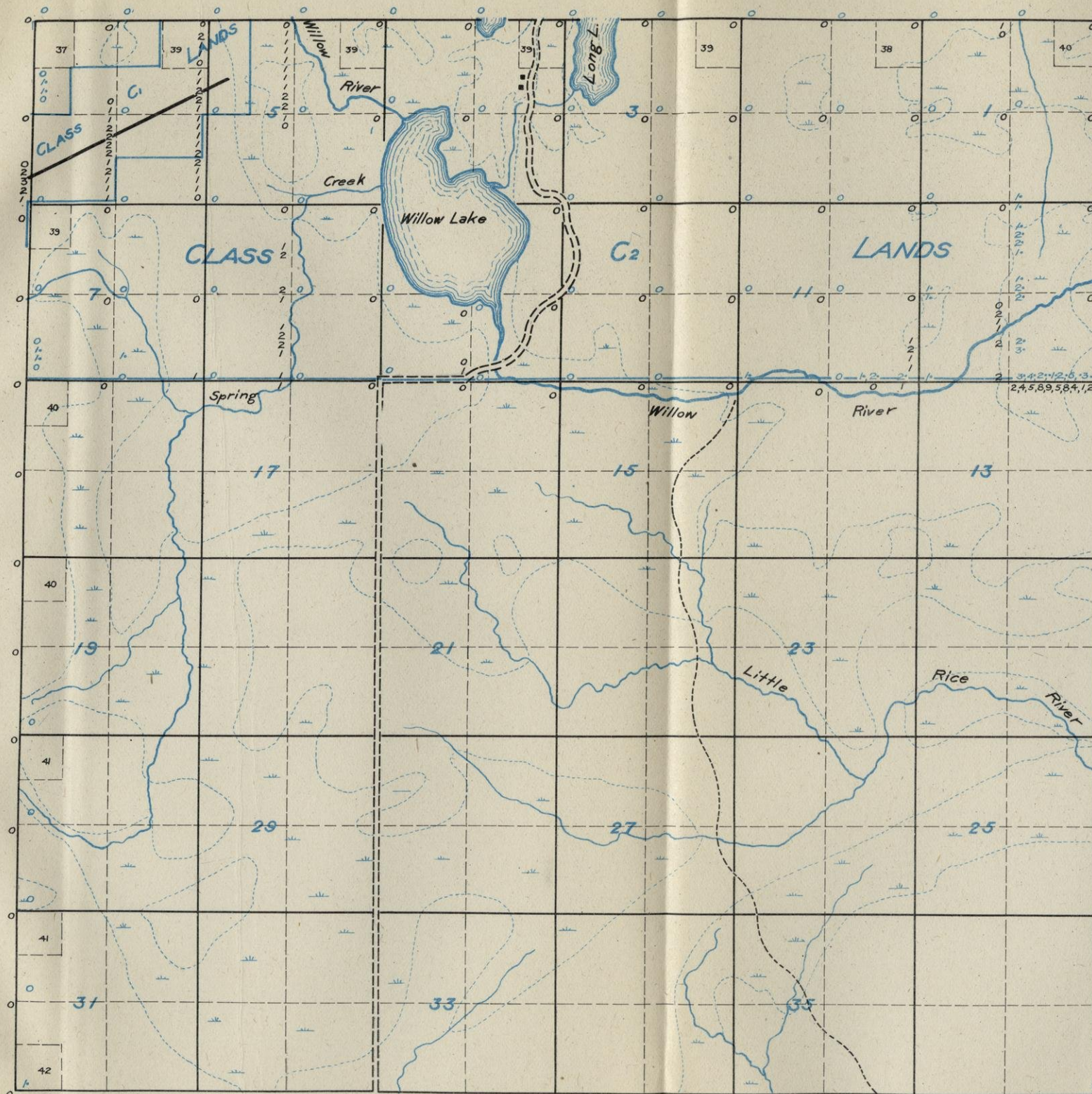

## TOWNSHIP 37 N., RANGE 3 E.

*Surface Features.*—Most of this township has a very gently undulating surface, low relief, and poor drainage. Extensive swamps are of common occurrence. Small areas of somewhat rougher and more elevated ground are found in the western parts of sections 18 and 30. A very pronounced and unusual topographic feature is the steep-sided valley in sections 5, 7 and 8 which is now occupied by a small stream flowing to the north. The walls of this valley are from 50 to 100 feet high and unusually steep for a valley in glacial drift. This valley was undoubtedly cut by a large and swiftly flowing glacial stream which appears to have flowed in a southerly direction. It is even more markedly developed in the township to the north.

There are but few roads in the township and while they are built on the property lines they are in poor condition except the 2 miles on the north of sections 29 and 30. Large quantities of hardwood timber still remain uncut.

*Glacial Drift.*—The two rougher areas in sections 18 and 30 are terminal moraine. The most northerly one extends into section 13 of the township to the west. All of the remainder of the township is ground moraine. The drift consists principally of silt, sand and gravel with some clay, and boulders which are very numerous in nearly all parts of the township.

The depth of the surface is unknown but undoubtedly will exceed 150 feet in most places. One well in section 28 is 110 feet deep and did not encounter ledge.

*General Geology.*—There are no exposures in or near this township, and definite information bearing on the character of the underlying formations is entirely lacking. As a result of the magnetic work it is believed that the rocks are of Huronian age.

*Magnetic Observations.*—A general discussion of magnetic observations and their significance is given in Chapter IV. Abnormal dip needle readings were obtained in two belts. The southernmost is a continuous line extending from the S. E. corner of section 1 to the S. W. corner of section 30, and was crossed by traverses every quarter mile. It continues both east and west in the adjoining townships, and has a total length of fully 10 miles. The dip needle readings obtained were low and the maximum on the line is not well defined but the persistent character of the attraction makes it ap-

pear quite probable that an iron formation may be the cause. Parallel to this and about  $1\frac{1}{2}$  miles north is a line running from the northeast corner of section 2 to the center of section 9. It is much less well defined than the one described above. Although quite irregular, this line may also be caused by a sedimentary formation.

*Land Classification.*—A general discussion of the principles of land classification employed in this work is given in Chapter V. Lands on the magnetic lines indicated are placed in class C1. All other lands in the township are placed in class C2.

*Exploration.*—Magnetic lines showing the persistent character of the one crossing the middle of this township are worthy of some attention from explorers. There is no positive assurance that it is caused by iron formation but a few well placed drill holes will determine the facts. Much of the work done in exploration for iron ore is wasted because of failure to make intelligent use of the geologic and magnetic data to be obtained by a careful preliminary survey, and because the geologic information given by the drill is not properly used as a guide for further work. The value of careful scientific methods of exploration therefore cannot be too strongly emphasized. If exploration is contemplated in this township the discussion of this subject in Chapter VI should be carefully studied.

# TOWN 37 N., R. 3E.

Survey Made in August, 1913

Under the Direction of

W. O. HOTCHKISS, State Geologist

AND

E. F. BEAN and O. W. WHEELWRIGHT,  
in charge of Field Parties

BY

R. W. CLARK, Chief of Party

W. C. BEAN, Asst. Geologist

E. T. HODGE, Asst. Geologist

## SYMBOLS AND ABBREVIATIONS.

The symbols and abbreviations used on this map are explained in Chapter II.

## TOWN AND RANGE LINES.

In constructing this map the south line of the township was laid off as a true east west line. The other boundary lines were then laid off with the lengths shown on the Land Survey plat. Some of the maps are therefore incorrect in shape but this is necessary because definite facts are lacking. The acreage of part of the lots in the north and west tier of sections is shown to give a check on the distances in these sections.

## LOCATIONS.

All locations are based on pacing traverses from government land corners. In many cases these were not found and it was necessary to continue the traverse several miles without a check. Locations of certain features may therefore be somewhat wrong. In such cases the feature sought may best be located by its relation to a stream, swamp, lake, or other feature shown on the map.

## PROFILES.

The locations of the profiles are shown on the map by dashed blue lines with black letters at the ends. Railroad profiles were furnished by the companies and show elevations of the ground rather than track in most cases; others are from road surveys by the State Highway Commission; most of them are hand level lines made by this Survey. Wherever possible the elevations above sea level are given. These elevations vary from 1050 to 1770 feet. A local datum plane was necessarily assumed in some cases. These cases are identifiable by the fact that the base line is always numbered 0.

## LAND CLASSIFICATION.

This is shown on the map by the blue letters. It is explained in the following township description and at length in chapter V.

## MAGNETIC DATA.

Dial compass readings are shown in blue figures. Eastward declinations are shown with a dot to the east and westward with a dot to west of the number. Dip needle readings are shown in black. All are positive except those preceded by the negative sign. All readings show deviation of needles from the normal reading of the instrument used. Normal readings are omitted from the map except at each quarter section corner. All abnormal readings are shown.

Traverses were made on lines indicated—usually the N-S section and quarter lines. Dip needle readings were taken each 50 paces, dial compass readings each 100 paces when sun permitted.

Magnetic lines are indicated by heavy black lines, solid where definite and dashed where doubtful.

**CAUTION:** Almost any kind of rock may be the cause of magnetic attraction. Do not fail to read the following description of this township, and also chapter IV., in which the magnetic attractions are discussed.

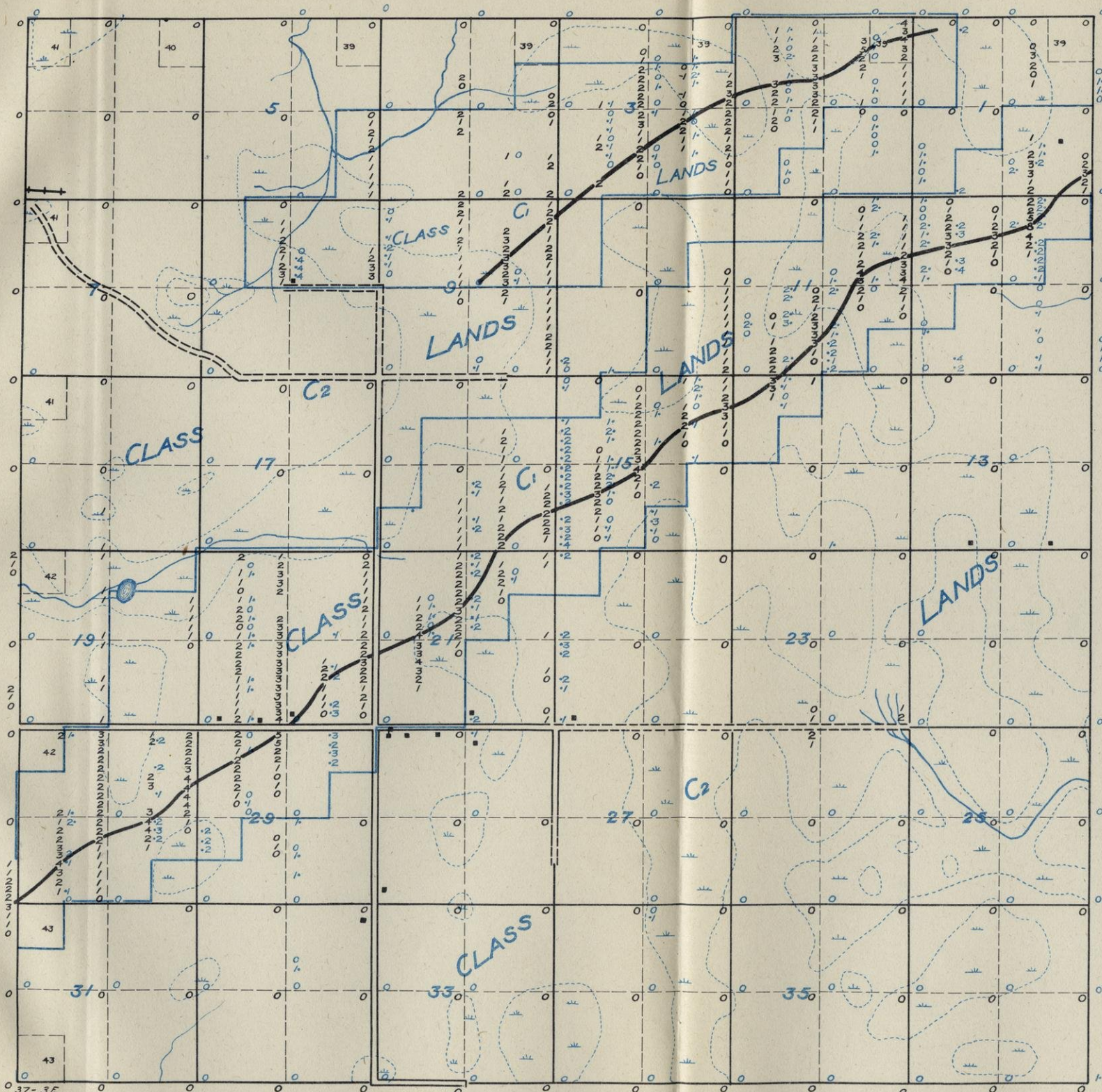

## TOWNSHIP 37 N., RANGE 2 E.

*Surface Features.*—Nearly all parts of this township have an undulating surface and a number of small disconnected areas have a rather rugged surface and local relief of as much as 40 to 60 feet. These areas occur in sections 5 and 6, in the center of 11, in the southern part of 12, the southern part of 13, in 23, and 24, in 26, 27, 35, and in 30, 31 and 32. The profile A-B shows a relief of 75 feet on the line between sections 26 and 35 and a difference of elevation of 115 feet from the valley of the Little Elk to the high point at the southeast corner of 26. The large hill with gentle slopes along the south line of section 28 is very characteristic of the undulating parts of this township. A rather remarkable hill of this kind is found along the logging railway which crosses the southern part of sections 1 and 2. The Little Elk river which drains most of the township is a rapidly flowing stream with a narrow and usually steep sided valley.

The settled parts of this township are well supplied with good roads but there are large areas in the northeastern and northwestern parts which have no roads at all. Practically all of the timber has been removed, but a few small scattered areas of hardwood still remain.

*Glacial Drift.*—Most of the drift is ground moraine, but small disconnected areas of terminal moraine occur in the places indicated above as showing rough topography. All of these areas present a rugged surface with steep slopes, but the local relief is seldom more than 50 feet and frequently is very much less.

The drift consists of silt, sand and gravel with more or less clay in places, and a considerable number of bowlders. This is true in the ground moraine as well as in the terminal moraine areas, but the terminal moraine is rather more gravelly.

The thickness of the drift is evidently great, judging from the fact that a well in section 25 went down 162 feet and another in section 31 was dug 146 feet without striking ledge. It is believed that the drift cover will exceed 150 feet in most parts of the township.

*General Geology.*—This township is in an area where rock exposures are entirely unknown and consequently there is little information on the character of the underlying formations. From general considerations and the results of the magnetic work, it is thought that Huronian rocks may underlie this entire township.

*Magnetic Observations.*—A general discussion of magnetic observations and their significance is given in Chapter IV. Over nearly all of the township abnormal dip needle readings varying from  $1^{\circ}$  to  $10^{\circ}$  were obtained. Broad irregular areas are more characteristic than well defined lines. Dashed lines are drawn connecting the maximum readings at a number of places on the map but it is believed that closer magnetic work might show that these connections should be made differently. Exceptions to this general condition are found in sections 5, 7 and 8 where a fairly well defined line is shown, and in sections 35 and 36 where there is a definite line of attraction which extends for many miles to the northeast. These lines are probably caused by sedimentary formations.

*Land Classification.*—A general discussion of the principles of land classification employed in this work is given in Chapter V. Lands on the magnetic lines in sections 5, 7, 8, 35 and 36 are placed in class C1. All others are placed in class C2 because the attractions are not regular although they are believed to be in areas of Huronian rocks.

*Exploration.*—Most of the magnetic attractions are too irregular to lead to the belief that they are caused by iron formation. The line in 35 and 36 is continuous for many miles to the east and it is not improbable that it marks the location of an iron formation. Undoubtedly this line is deserving of some attention. The line in sections 5 and 7 also has some of the characteristics of a line caused by iron formation. Much of the work done in exploration for iron ore is wasted because of failure to make intelligent use of the geologic and magnetic data to be obtained by a careful preliminary survey, and because the geologic information given by the drill is not properly used as a guide for further work. The value of careful scientific methods of exploration therefore cannot be too strongly emphasized. If exploration is contemplated in this township the discussion of this subject in Chapter VI should be carefully studied.

**TOWN 37 N., R. 2E.**

Survey Made in August, 1913

Under the Direction of

W. O. HOTCHKISS, State Geologist

AND

E. F. BEAN and O. W. WHEELWRIGHT,  
in charge of Field Parties

BY

J. C. SCOLLES, Chief of Party

F. E. WILLIAMS, Asst. Geologist

C. OLSON, Asst. Geologist

**SYMBOLS AND ABBREVIATIONS.**

The symbols and abbreviations used on this map are explained in Chapter II.

**TOWN AND RANGE LINES.**

In constructing this map the south line of the township was laid off as a true east west line. The other boundary lines were then laid off with the lengths shown on the Land Survey plat. Some of the maps are therefore incorrect in shape but this is necessary because definite facts are lacking. The acreage of part of the lots in the north and west tier of sections is shown to give a check on the distances in these sections.

**LOCATIONS.**

All locations are based on pacing traverses from government land corners. In many cases these were not found and it was necessary to continue the traverse several miles without a check. Locations of certain features may therefore be somewhat wrong. In such cases the feature sought may best be located by its relation to a stream, swamp, lake, or other feature shown on the map.

**PROFILES.**

The locations of the profiles are shown on the map by dashed blue lines with black letters at the ends. Railroad profiles were furnished by the companies and show elevations of the ground rather than track in most cases; others are from road surveys by the State Highway Commission; most of them are hand level lines made by this Survey. Wherever possible the elevations above sea level are given. These elevations vary from 1050 to 1770 feet. A local datum plane was necessarily assumed in some cases. These cases are identifiable by the fact that the base line is always numbered 0.

**LAND CLASSIFICATION.**

This is shown on the map by the blue letters. It is explained in the following township description and at length in chapter V.

**MAGNETIC DATA.**

Dial compass readings are shown in blue figures. Eastward declinations are shown with a dot to the east and westward with a dot to west of the number. Dip needle readings are shown in black. All are positive except those preceded by the negative sign. All readings show deviation of needles from the normal reading of the instrument used. Normal readings are omitted from the map except at each quarter section corner. All abnormal readings are shown.

Traverses were made on lines indicated—usually the N-S section and quarter lines. Dip needle readings were taken each 50 paces, dial compass readings each 100 paces when sun permitted.

Magnetic lines are indicated by heavy black lines, solid where definite and dashed where doubtful.

**CAUTION:** Almost any kind of rock may be the cause of magnetic attraction. Do not fail to read the following description of this township, and also chapter IV., in which the magnetic attractions are discussed.

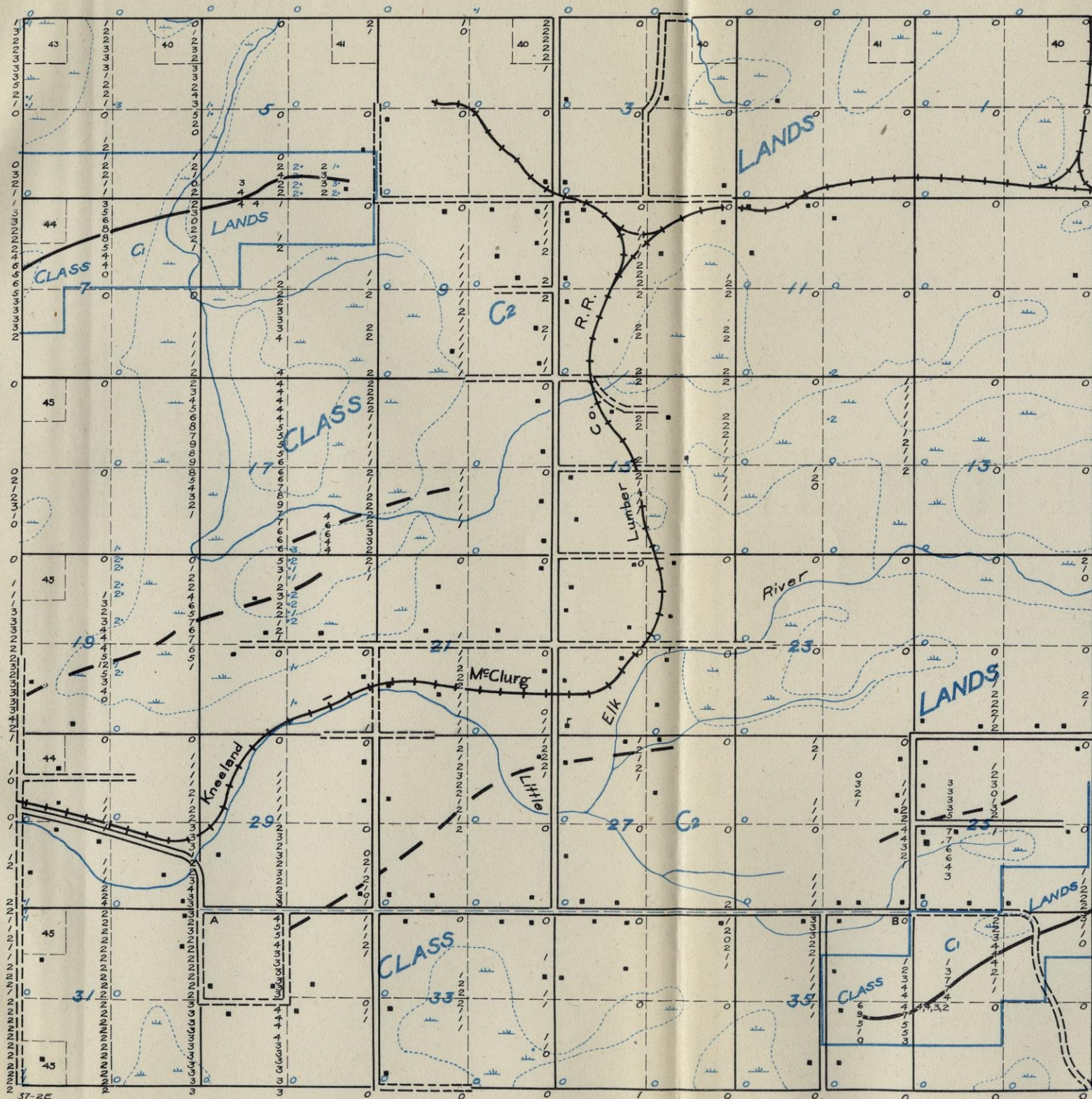

PROFILE  
VERTICAL SCALE: 1 space = 20'  
HORIZONTAL SCALE: same as map

LOCAL DATUM

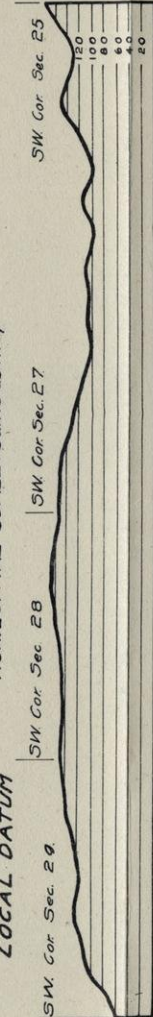



## TOWNSHIP 37 N., RANGE 6 W.

*Surface Features.*—Most of this township is monotonously flat and poorly drained. Relief of more than 30 feet is uncommon. There is a small area of rougher ground in the north half of sections 3 and 4.

The township is practically without roads except in the west tier of sections, and such roads as exist are impassable except in dry seasons. The timber is practically all removed. Settlement has progressed to a very slight extent in the western part.

*Glacial Drift.*—Nearly all of the township is covered by ground moraine with a flat to gently undulating surface. A terminal moraine extends from the north, covering the north one-third of sections 3 and 4. This is rough and hummocky but not of great relief. In the western part of the township there is an outwash plain extending from section 6 to section 30. In section 6 it is less than  $\frac{1}{4}$  mile wide but increases to a width of  $1\frac{1}{2}$  miles in sections 19 and 20. It is a very flat and poorly drained deposit of sand and gravel. The drift in the ground moraine area consists of silt, sand and gravel. Boulders are very numerous in the southern third.

No ledge is exposed in the township and no borings have passed through the glacial drift to the rock, so there is no definite evidence upon which to base an estimate of the thickness of the drift. It is believed to be 75 feet or more in depth.

*General Geology.*—No rock exposures were found and the character of the rock can be judged only from work done in adjacent townships, and from the results of the magnetic work. Most of the township is thought to be underlain by granite but it is believed that a belt of Huronian rocks about 2 miles wide extends east and west across the township just south of the center. This probably extends across the southeast corner of T. 37-7 W. and connects with the belt in T. 36-7 W.

*Magnetic Observations.*—A general discussion of magnetic observations and their significance is given in Chapter IV. For two miles south of the middle line of the township abnormal magnetic readings were obtained on every line of traverse. Connecting the maximum readings results in a series of short, nearly parallel lines which are continuous, brokenly, for miles to the southwest. It is very probable that they are caused by a sedimentary formation, either iron formation or magnetic slate. Very mild attractions were

obtained in a few scattered localities in the northern part but they do not connect to form lines and are thought to be caused by magnetite in the igneous rocks.

*Land Classification.*—The principles of land classification employed in this work are discussed in Chapter V. All lands along the magnetic lines are classed as C1. Since there is no information to warrant a more definite classification all other lands are placed in class C2.

*Exploration.*—Since it is probable that some of the magnetic lines are due to iron formation it might be well to put down a very few drill holes to determine the character of the rock causing the attraction. The extension of this magnetic field to the west probably offers somewhat more inducement for explorers but that part in this township deserves some attention. Much of the work done in exploration for iron ore is wasted because of failure to make intelligent use of the geologic and magnetic data to be obtained by a careful preliminary survey, and because the geologic information given by the drill is not properly used as a guide for further work. The value of careful scientific methods of exploration therefore cannot be too strongly emphasized. If exploration is contemplated in this township the discussion of this subject in Chapter VI should be carefully studied.

# TOWN 37 N., R. 6W.

Survey Made in September, 1914

Under the Direction of  
W. O. HOTCHKISS, State Geologist  
AND  
E. F. BEAN and O. W. WHEELWRIGHT,  
in charge of Field Parties

BY  
W. C. BEAN, Chief of Party  
G. S. NISHIHARA, Asst. Geologist  
L. M. NEUMANN, Asst. Geologist

### SYMBOLS AND ABBREVIATIONS.

The symbols and abbreviations used on this map are explained in Chapter II.

### TOWN AND RANGE LINES.

In constructing this map the south line of the township was laid off as a true east west line. The other boundary lines were then laid off with the lengths shown on the Land Survey plat. Some of the maps are therefore incorrect in shape but this is necessary because definite facts are lacking. The acreage of part of the lots in the north and west tier of sections is shown to give a check on the distances in these sections.

### LOCATIONS.

All locations are based on pacing traverses from government land corners. In many cases these were not found and it was necessary to continue the traverse several miles without a check. Locations of certain features may therefore be somewhat wrong. In such cases the feature sought may best be located by its relation to a stream, swamp, lake, or other feature shown on the map.

### PROFILES.

The locations of the profiles are shown on the map by dashed blue lines with black letters at the ends. Railroad profiles were furnished by the companies and show elevations of the ground rather than track in most cases; others are from road surveys by the State Highway Commission: most of them are hand level lines made by this Survey. Wherever possible the elevations above sea level are given. These elevations vary from 1050 to 1770 feet. A local datum plane was necessarily assumed in some cases. These cases are identifiable by the fact that the base line is always numbered 0.

### LAND CLASSIFICATION.

This is shown on the map by the blue letters. It is explained in the following township description and at length in chapter V.

### MAGNETIC DATA.

Dial compass readings are shown in blue figures. Eastward declinations are shown with a dot to the east and westward with a dot to the west of the number. Dip needle readings are shown in black. All are positive except those preceded by the negative sign. All readings show deviation of needles from the normal reading of the instrument used. Normal readings are omitted from the map except at each quarter section corner. All abnormal readings are shown.

Traverses were made on lines indicated—usually the N-S section and quarter lines. Dip needle readings were taken each 50 paces, dial compass readings each 100 paces when sun permitted.

Magnetic lines are indicated by heavy black lines, solid where definite and dashed where doubtful.

**CAUTION:** Almost any kind of rock may be the cause of magnetic attraction. Do not fail to read the following description of this township, and also chapter IV., in which the magnetic attractions are discussed.

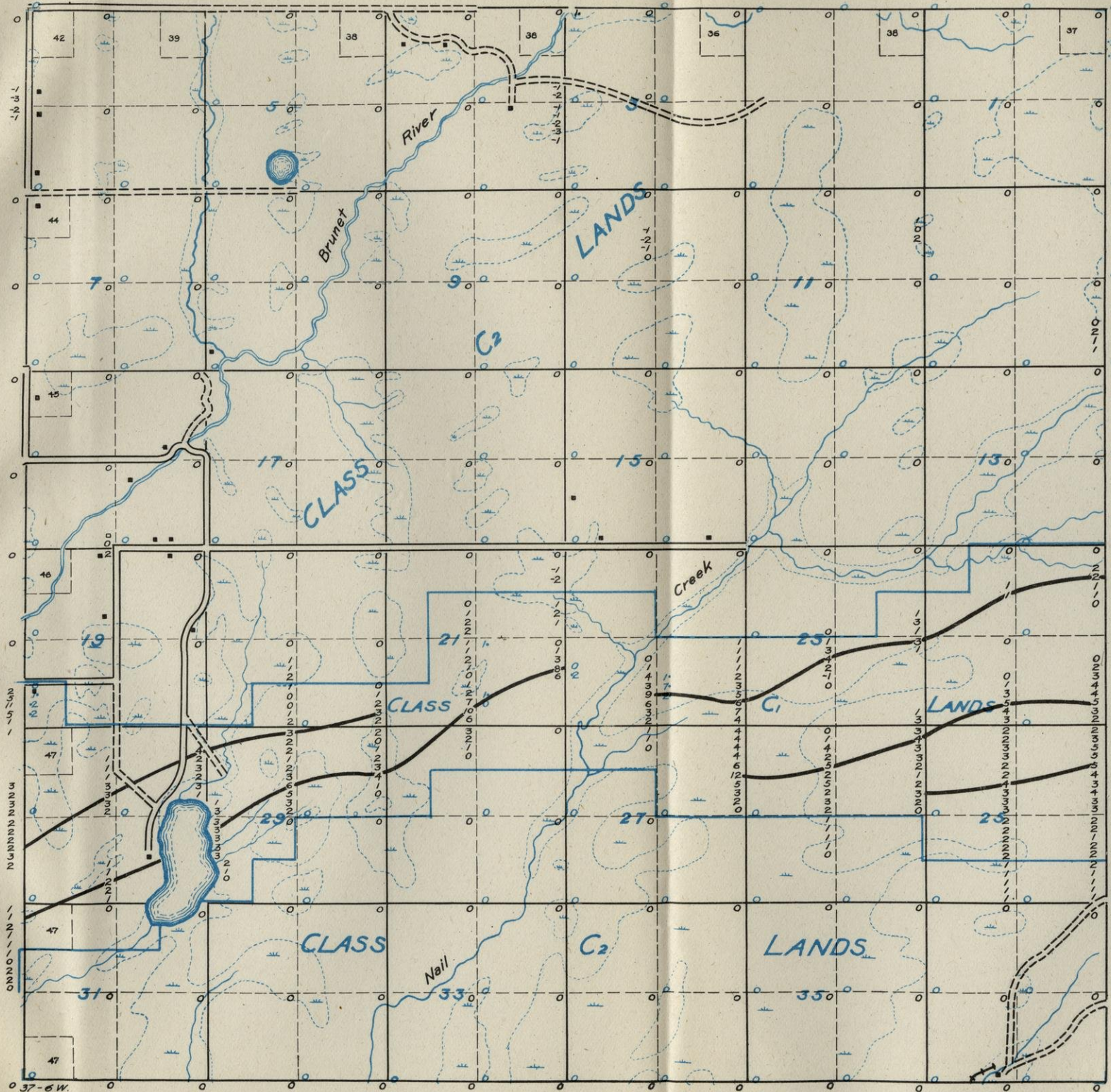

## TOWNSHIP 37 N., RANGE 7 W.

*Surface Features.*—The township is characteristically flat or gently undulating except in the extreme northwestern part and along a strip from  $\frac{1}{2}$  to 1 mile wide extending from the northwest corner of section 15 to the S.  $\frac{1}{4}$  S. of 35. The former area is markedly rugged and the latter moderately so. The Chippewa has cut deeply into the drift, resulting in rugged topography along its course and the erosion effects even of the smaller streams are quite pronounced. The South Fork of the Weirgor at Exeland flows 30 or 40 feet below the level of the plain upon which this village is located. There is a gradual rise of 100 feet southwest of Exeland but the surface is very gently undulating. This is shown on profile A-B which also shows the general level nature of the surface.

The roads in this township are usually in fairly good condition although most of them require considerable grading to make first class roads. Some hardwood timber remains in the southwestern part but all of the remainder of the township has been cut over. A thriving farming community is being developed in the eastern part.

*Glacial Drift.*—Most of the township east of the Chippewa River is a level outwash plain. A strip 1 mile wide extending along Weirgor Creek from sections 8 and 9, southeast to the township line in section 34, is a level outwash plain which has, however, been somewhat dissected in its southern part. A rough hummocky terminal moraine 1 mile wide and 2 miles long is found east of the railroad in the northwestern part and a more gentle terminal moraine extends from section 15 to 35, varying in width from  $\frac{1}{4}$  to 1 mile. The remainder is ground moraine. The drift in the outwash and terminal moraines is composed of sand and gravel with some silt. In the ground moraines silt is a more prominent constituent. Boulders as a rule are not common even in the terminal moraines and the eastern part of the township is remarkable free from them.

The depth of the drift is not known, but the presence of outcrops in the Chippewa River would seem to indicate a moderate depth. A well in the S. W.  $\frac{1}{4}$  of 14 was put down to a depth of 84 feet without encountering ledge. It is believed, however, that the depth of surface will seldom exceed 100 feet.

*General Geology.*—A few outcrops of granite are found along the banks of the Chippewa River. Two occurrences are in the N. E.  $\frac{1}{4}$

of the N. E.  $\frac{1}{4}$  of section 3. The rock here is a rather coarse grained granite gneiss. In section 10 an outcrop occurs about 150 paces west of the river a short distance east of the center of the section. This is a fine grained granite gneiss intruded by a coarse pegmatite. In section 25 near the E.  $\frac{1}{4}$  S. is a small outcrop of granite gneiss. Lack of exposures in other parts of the township makes it impossible to definitely state the character of the underlying rock but it is believed that it is largely granite gneiss similar to that exposed along the Chippewa River. From the results of the magnetic work it appears that a Huronian belt crosses the southern part as shown on the map, plate I.

*Magnetic Observations.*—A general discussion of magnetic observations and their significance is given in Chapter IV. A broad area of rather irregular attractions was found in the southeastern part. Lines connecting the maximum readings are somewhat doubtful. While irregular in this township this attraction is part of a belt continuous for at least 15 miles and it seems improbable that it is caused by other than sedimentary rocks. The irregularity may be due in part to intrusion of igneous rocks. In a number of instances in other parts of the township negative readings were obtained and it is believed that these are due to the presence of a pink pegmatite which has been found to contain magnetite and to exert a strong negative pull upon the dip needle. The magnetic pegmatite is exposed at the Radisson dam in the township to the north.

*Land Classification.*—For a thorough understanding of the principles of land classification employed in this work the reader is referred to Chapter V. All lands in the immediate vicinity of outcropping granites are placed in class D. Lands in the magnetic area in the southeastern part are classed as C1. All other lands are placed in class C2, although it is believed that most of the township is underlain by granite.

*Exploration.*—The magnetic line extending from the east side of T. 37-6 W. to a point well toward the western side of T. 36-8 W. is deserving of some attention. From the results of this survey it appears that the western third is the most promising but the finding of iron formation there would make the entire area explorable ground. That portion of the magnetic area in this township cannot be especially recommended for exploration but a very small amount of drilling would serve to show the cause of the attraction and to indicate whether the work could be continued with profit.

TOWN 37 N., R. 7 W.

Survey Made in July, 1914

Under the Direction of  
W. O. HOTCHKISS, State Geologist

AND  
E. F. BEAN and O. W. WHEELWRIGHT,  
in charge of Field Parties

BY  
W. C. BEAN, Chief of Party  
G. S. NISHIHARA, Asst. Geologist  
HOWARD QUINLAN, Asst. Geologist

**SYMBOLS AND ABBREVIATIONS.**  
The symbols and abbreviations used on this map are explained in Chapter II.

**TOWN AND RANGE LINES.**  
In constructing this map the south line of the township was laid off as a true east west line. The other boundary lines were then laid off with the lengths shown on the Land Survey plat. Some of the maps are therefore incorrect in shape but this is necessary because definite facts are lacking. The acreage of part of the lots in the north and west tier of sections is shown to give a check on the distances in these sections.

**LOCATIONS.**  
All locations are based on pacing traverses from government land corners. In many cases these were not found and it was necessary to continue the traverse several miles without a check. Locations of certain features may therefore be somewhat wrong. In such cases the feature sought may best be located by its relation to a stream, swamp, lake, or other feature shown on the map.

**PROFILES.**  
The locations of the profiles are shown on the map by dashed blue lines with black letters at the ends. Railroad profiles were furnished by the companies and show elevations of the ground rather than track in most cases; others are from road surveys by the State Highway Commission: most of them are hand level lines made by this Survey. Wherever possible the elevations above sea level are given. These elevations vary from 1050 to 1770 feet. A local datum plane was necessarily assumed in some cases. These cases are identifiable by the fact that the base line is always numbered 0.

**LAND CLASSIFICATION.**  
This is shown on the map by the blue letters. It is explained in the following township description and at length in chapter V.

**MAGNETIC DATA.**  
Dial compass readings are shown in blue figures. Eastward declinations are shown with a dot to the east and westward with a dot to west of the number. Dip needle readings are shown in black. All are positive except those preceded by the negative sign. All readings show deviation of needles from the normal reading of the instrument used. Normal readings are omitted from the map except at each quarter section corner. All abnormal readings are shown.

Traverses were made on lines indicated—usually the N-S section and quarter lines. Dip needle readings were taken each 50 paces, dial compass readings each 100 paces when sun permitted.

Magnetic lines are indicated by heavy black lines, solid where definite and dashed where doubtful.

**CAUTION:** Almost any kind of rock may be the cause of magnetic attraction. Do not fail to read the following description of this township, and also chapter IV., in which the magnetic attractions are discussed.

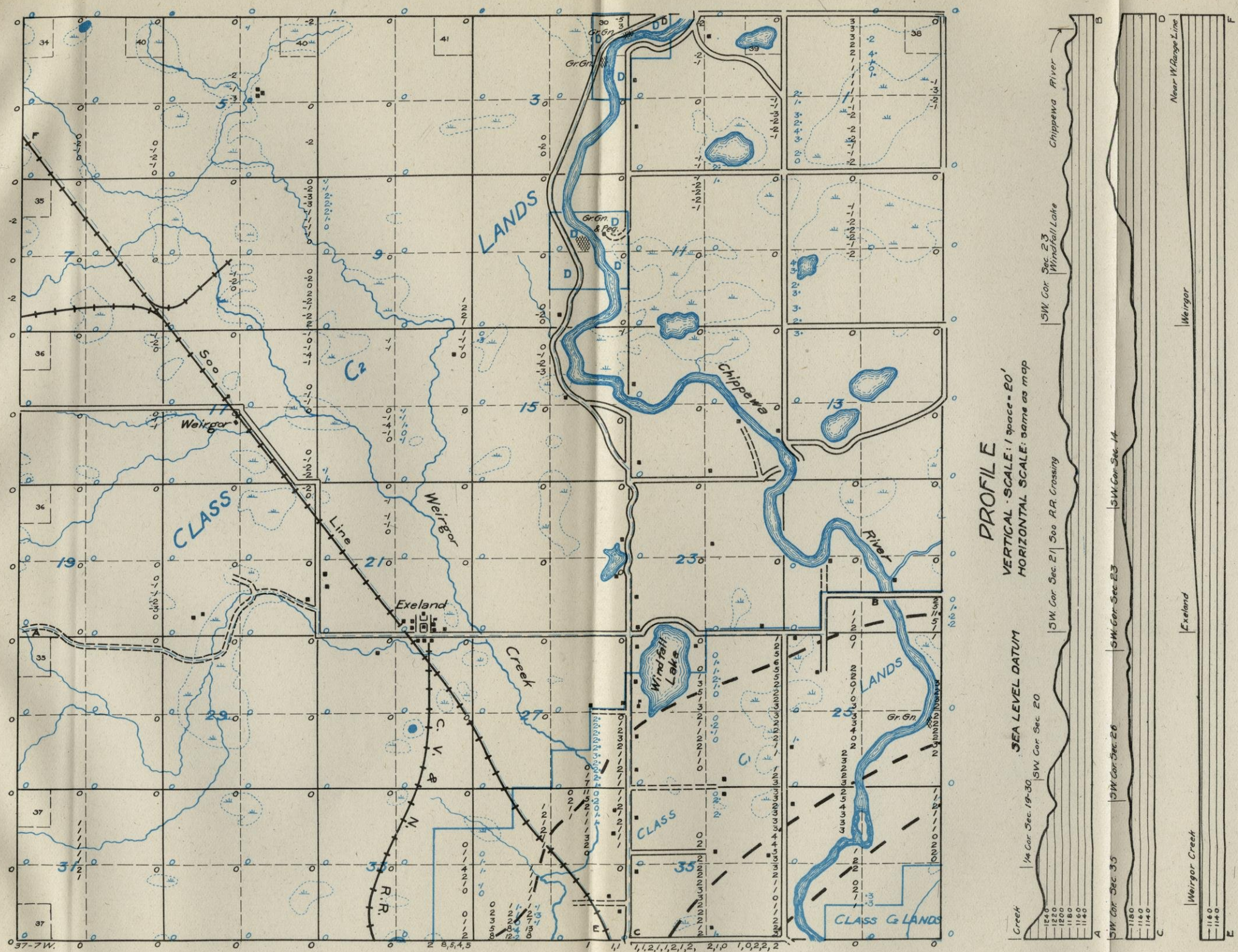

Much of the work done in exploration for iron ore is wasted because of failure to make intelligent use of the geologic and magnetic data to be obtained by a careful preliminary survey, and because the geologic information given by the drill is not properly used as a guide for further work. The value of careful scientific methods of exploration therefore cannot be too strongly emphasized. If exploration is contemplated in this township the discussion of this subject in Chapter VI should be carefully studied.

## TOWNSHIP 37 N., RANGE 8 W.

*Surface Features.*—Most of this township is characterized by very rough topography and large steep hills are common. The southeastern part is more gently undulating. A large valley extends southwest through Meteor and Deer Lake, and connects with the valley of Sucker Creek in the township to the west. The accompanying profiles show very well the rugged character of the township. The maximum range of elevation between the lowest known point, the E.  $\frac{1}{4}$  S. of 13, and the highest point, about  $\frac{1}{4}$  mile south of the N. E. corner of section 20, is 500 feet. The elevation at this latter point is about 1770 feet above sea level which makes it the highest known point in the western part of the area covered by this report. This is fully 250 feet above the highest point on Flambeau Ridge and is known to be exceeded by no other elevation in this area except the hills in T. 36-12 E.

The roads in this township are fairly well graded, but are very hilly. The one most used is that from Meteor northwest to Yarnell. Numerous areas of hardwood timber are scattered over the township but little of the land has been cleared as yet, although settlers are moving in rapidly.

*Glacial Drift.*—Undoubtedly the topography in this township is to a very large extent rock controlled and the great range of elevations is due to pre-glacial erosion. Most of the drift consists of ground moraine deposits which are much dissected in places. In the north half of sections 1 and 2 is a small area of rough hummocky terminal moraine which does not, however, rise to an elevation of more than 50 feet above the ground moraine in the vicinity. The glacial drift consists largely of silt with some sand and gravel in the ground moraine areas, whereas in the terminal moraine in the northeastern part it is composed very largely of sand.

The rock outcrops are limited to the eastern escarpment of the Barron quartzite and do not serve as a good indication of the depth of the surface elsewhere. A well at Meteor is reported to have struck rock at a depth of 40 feet, but it is believed that the depth of the drift deposits will exceed this figure in nearly every part of the township.

*General Geology.*—The entire township except sections 1, 25, and 36, and parts of the east sides of sections 2, 12, 13, 24, 26, and 35, is underlain by the Barron quartzite. This rock outcrops in numerous places in sections 10 and 11 and along the creek on the east side



# TOWN 37 N., R. 8W.

Survey Made in August, 1914

Under the Direction of  
**W. O. HOTCHKISS**, State Geologist  
AND  
**E. F. BEAN** and **O. W. WHEELWRIGHT**,  
in charge of Field Parties  
BY

**W. C. BEAN**, Chief of Party  
**G. S. NISHIHARA**, Asst. Geologist  
**G. M. EHLERS**, Asst. Geologist  
**L. M. NEUMANN**, Asst. Geologist

**SYMBOLS AND ABBREVIATIONS.**  
The symbols and abbreviations used on this map are explained in Chapter II.

**TOWN AND RANGE LINES.**  
In constructing this map the south line of the township was laid off as a true east west line. The other boundary lines were then laid off with the lengths shown on the Land Survey plat. Some of the maps are therefore incorrect in shape but this is necessary because definite facts are lacking. The acreage of part of the lots in the north and west tier of sections is shown to give a check on the distances in these sections.

**LOCATIONS.**  
All locations are based on pacing traverses from government land corners. In many cases these were not found and it was necessary to continue the traverse several miles without a check. Locations of certain features may therefore be somewhat wrong. In such cases the feature sought may best be located by its relation to a stream, swamp, lake, or other feature shown on the map.

**PROFILES.**  
The locations of the profiles are shown on the map by dashed blue lines with black letters at the ends. Railroad profiles were furnished by the companies and show elevations of the ground rather than track in most cases; others are from road surveys by the State Highway Commission; most of them are hand level lines made by this Survey. Wherever possible the elevations above sea level are given. These elevations vary from 1050 to 1770 feet. A local datum plane was necessarily assumed in some cases. These cases are identifiable by the fact that the base line is always numbered 0.

**LAND CLASSIFICATION.**  
This is shown on the map by the blue letters. It is explained in the following township description and at length in chapter V.

**MAGNETIC DATA.**  
Dial compass readings are shown in blue figures. Eastward declinations are shown with a dot to the east and westward with a dot to west of the number. Dip needle readings are shown in black. All are positive except those preceded by the negative sign. All readings show deviation of needles from the normal reading of the instrument used. Normal readings are omitted from the map except at each quarter section corner. All abnormal readings are shown.

Traverses were made on lines indicated—usually the N-S section and quarter lines. Dip needle readings were taken each 50 paces, dial compass readings each 100 paces when sun permitted.

Magnetic lines are indicated by heavy black lines, solid where definite and dashed where doubtful.

**CAUTION:** Almost any kind of rock may be the cause of magnetic attraction. Do not fail to read the following description of this township, and also chapter IV., in which the magnetic attractions are discussed.

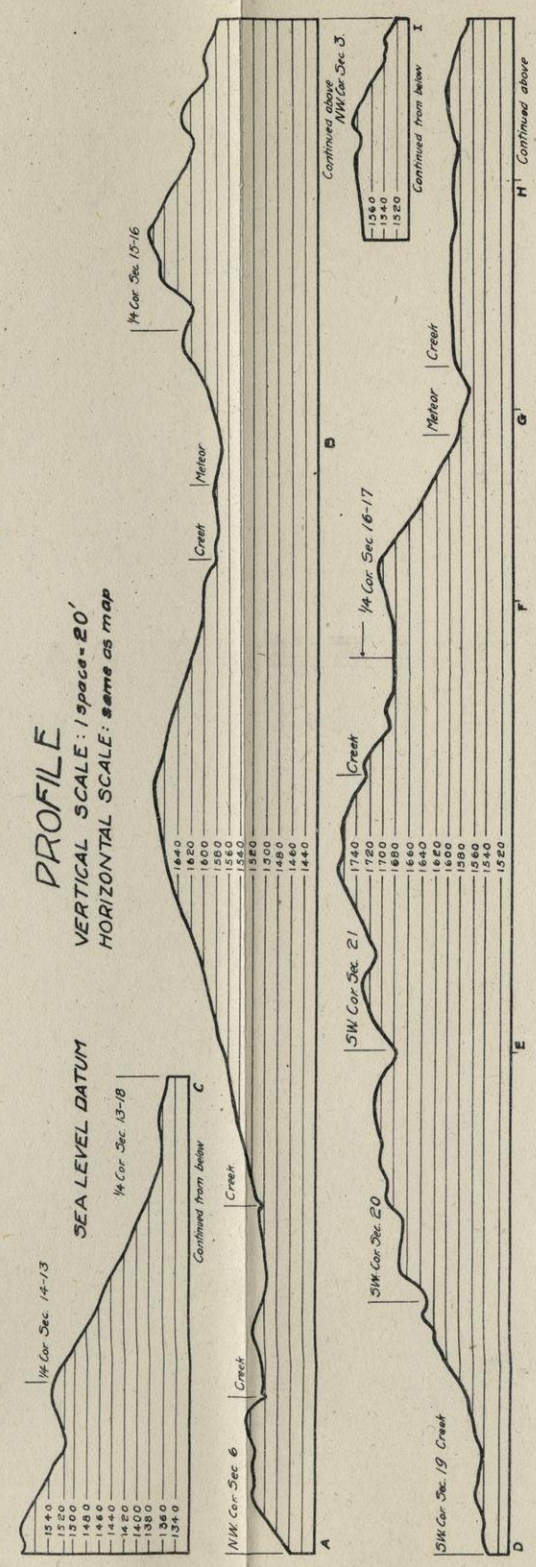
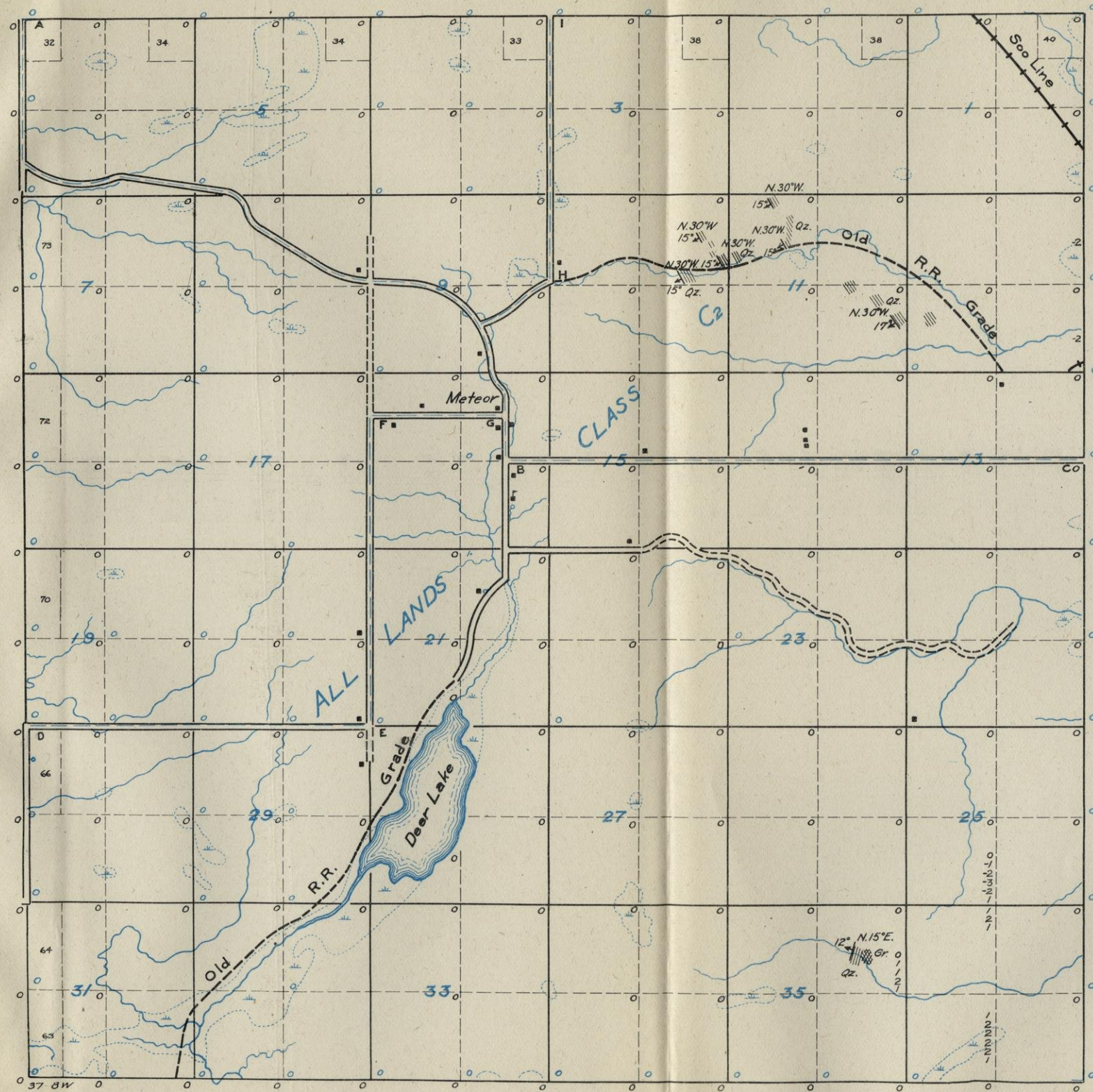

**PROFILE**  
VERTICAL SCALE: 1 space = 20'  
HORIZONTAL SCALE: same as map

SEA LEVEL DATUM

1/4 Cor. Sec. 14-13

1/4 Cor. Sec. 13-18

1/4 Cor. Sec. 14-16

Continued above 1/4 Cor. Sec. 3

Continued from below 1560 1540 1520

H Continued above

Continued from below

Creek

SW Cor. Sec. 21

SW Cor. Sec. 20

SW Cor. Sec. 19 Creek

E

F

G

H

1540 1520 1500 1480 1460 1440 1420 1400 1380 1360 1340

1740 1720 1700 1680 1660 1640 1620 1600 1580 1560 1540 1440

1/4 Cor. Sec. 6

SW Cor. Sec. 20

SW Cor. Sec. 19

D

of section 35. In all cases the quartzite is composed of well cemented fine quartz sand, with occasional pebbles of quartz ranging in size up to a half inch in diameter. The color varies from white through pink to a dark brick red. The quartzite strikes about N. 30° W. in the northern part and nearly north and south in section 35, and dips west at an angle averaging about 15°. The evidence points to the fact that this formation does not attain any great thickness in this township. Underneath and almost directly in contact with the quartzite in section 25, is a red decomposed granite gneiss similar to the rocks found underneath the quartzite in T. 36-7 W. This is the only representative of the underlying older rocks found in this township.

*Magnetic Observations.*—A general discussion of magnetic observations and their significance is given in Chapter IV. A very small area in the southeastern part of the township shows some irregular abnormal dip needle readings which are probably caused by igneous rocks. Elsewhere the township is free from abnormal attractions.

*Land Classification.*—For a thorough understanding of the principles of land classification employed in this work the reader is referred to Chapter V. All lands in this township are placed in class C2 for the reason that there is very little information as to the character of the underlying pre-Cambrian. It is thought that the Barron quartzite does not usually attain sufficient thickness to seriously interfere with the chances of finding iron formation in the older rocks if such exists and it is therefore left out of consideration in making the classification. The extent of the granite in section 35 is not known so a different classification is not assigned to lands in the vicinity although it is very likely that the granite may cover a considerable area.

*Exploration.*—The geological evidence in this township does not warrant exploration for iron ore. There is nothing to indicate the presence of iron formation and while it may exist the chances of finding it by drilling are so slight as not to justify the search.

## TOWNSHIP 37 N., RANGE 9 W.

*Surface Features.*—This township is divided into three parts with strongly contrasting surface features. The northwestern area, comprising all of that part of the township northwest of an irregular line between the northeast corner of section 2 and the W.  $\frac{1}{4}$  S. of 30, is characterized by rugged topography with many rounded knobs, from 50 to 100 feet high, and numerous depressions, many of which are occupied by lakes. In its center is Lake Chetac, a narrow body of water about 6 miles long occupying a valley which is believed to be of pre-glacial origin.

Extending diagonally from the northeast to the southwest corners of the township is a strip  $\frac{1}{2}$  to 2 miles wide of more level ground having but very slight relief. There is, however, a gradual rise in elevation of 160 feet from the southwest to the northeastern parts of the township. East of this is another area of rough topography, strong relief, and steep slopes. From the schoolhouse at the southwest corner of section 29 to the southwest of section 25, there is a rise of 260 feet along the wagon road. While the elevation of the eastern part of this area is greatest, it is less rugged than in sections 27, 28 and 34, where steep knob-like hills and water-filled depressions are of common occurrence.

A pronounced topographic feature is found along the south side of sections 35 and 36 where Sucker creek occupies a gorge about 300 feet wide and 60 feet deep with steep talus slope walls. All evidence points to the pre-glacial origin of this valley.

Profile C-D gives elevations above sea level along the road 1 mile north of the south township line and shows the rough nature of the country as well as the extremely hilly road. Profile G-H crosses the more level area in the central part, and shows the gradual rise toward the northeast corner of the township. Profile E-F follows the edge of Lake Chetac and gives no adequate idea of the topography in this section of the township.

Roads are few, and except in the northwest corner are not well graded. A road extends from east to west across the north side of the southern tier of sections, but is very hilly and little used at the present time. The road along the west side of Lake Chetac is little used but is in passable condition because of the fact that it traverses a sandy and gravelly country. Most of the township was originally covered with pine timber which has been entirely removed. Sections 13, 24, 25, and 36 are in a hardwood area and a small amount of this timber still remains there.

*Glacial Drift.*—Terminal moraine of a very pronounced type occupies the rough area in the northwestern part of the township and the south central part, and merges gradually into the flat area traversed by the Omaha Railroad. In the terminal moraines the drift is composed of sand and gravel with some silt and boulders. It is characteristically a sandy and gravelly country and as a rule boulders are not very numerous. The more level strip along the Omaha Railroad is ground moraine. The drift here is rather more silty than in the terminal moraine but still is of a sandy and gravelly nature. The high ground in the southeastern part of the township is also moraine deposited over the Barron quartzite. The drift here is decidedly more silty and the character of the soil is distinctly different from the more sandy areas.

On the east side of the township the thickness of the drift is probably not great as a rule, as indicated by occasional occurrences of rock outcrops. Over the remainder of the township it is undoubtedly deep, probably varying from 100 to 200 feet.

*General Geology.*—The Barron quartzite is exposed in a very small area along a creek near the north quarter post of section 1. The rock here is of brick red color, is composed of well cemented fine quartz sand grains and is practically flat lying. In the southern part of sections 35 and 36 on the north side of a pre-glacial gorge, talus slopes occur intermittently for about 1 mile east and west, and ledge is exposed in place about the center line of section 36. It strikes somewhat north of east and dips very gently to the northwest. The quartzite in these exposures is light colored, and is stain-banded with narrow pink and white bands which often have the appearance of cross-bedding, but assume a variety of forms. This banded quartzite is found in a number of other localities where the Barron formation is exposed. Some of the talus slopes at this point show small quantities of pipestone. No other exposures of rock are found. It is considered very probable that the quartzite underlies most of the eastern two-thirds of the township, but there is doubt about its presence in the western part. Sandstone will probably be found here. Of the older rocks beneath nothing is known.

*Magnetic Observations.*—With the exception of a small area in section 36, no abnormal magnetic attraction was found. That in 36 is very local and is not believed to be of any importance.

*Land Classification.*—The principles of land classification employed in this work are discussed in Chapter V. All lands in this town-

ship are placed in class C2, because no evidence whatever was obtained of the character of the older rocks. The Barron quartzite has not been taken into consideration when making this classification, because it is thought to be too thin to materially affect the mineral value of the land where it is found.

*Exploration.*—There is no geological evidence to warrant exploration in this township. While iron formation may be present, the chance of finding it by drilling is so small as not to warrant the expense.

**TOWN 37 N., R. 9 W.**

Survey Made in July, 1914

Under the Direction of  
**W. O. HOTCHKISS**, State Geologist  
AND  
**E. F. BEAN** and **O. W. WHEELWRIGHT**,  
in charge of Field Parties  
BY  
**R. W. CLARK**, Chief of Party  
**J. R. ROBERTS**, Asst. Geologist  
**W. G. CRAWFORD**, Asst. Geologist

**SYMBOLS AND ABBREVIATIONS.**  
The symbols and abbreviations used on this map are explained in Chapter II.

**TOWN AND RANGE LINES.**  
In constructing this map the south line of the township was laid off as a true east west line. The other boundary lines were then laid off with the lengths shown on the Land Survey plat. Some of the maps are therefore incorrect in shape but this is necessary because definite facts are lacking. The acreage of part of the lots in the north and west tier of sections is shown to give a check on the distances in these sections.

**LOCATIONS.**  
All locations are based on pacing traverses from government land corners. In many cases these were not found and it was necessary to continue the traverse several miles without a check. Locations of certain features may therefore be somewhat wrong. In such cases the feature sought may best be located by its relation to a stream, swamp, lake, or other feature shown on the map.

**PROFILES.**  
The locations of the profiles are shown on the map by dashed blue lines with black letters at the ends. Railroad profiles were furnished by the companies and show elevations of the ground rather than track in most cases; others are from road surveys by the State Highway Commission; most of them are hand level lines made by this Survey. Wherever possible the elevations above sea level are given. These elevations vary from 1050 to 1770 feet. A local datum plane was necessarily assumed in some cases. These cases are identifiable by the fact that the base line is always numbered 0.

**LAND CLASSIFICATION.**  
This is shown on the map by the blue letters. It is explained in the following township description and at length in chapter V.

**MAGNETIC DATA.**  
Dial compass readings are shown in blue figures. Eastward declinations are shown with a dot to the east and westward with a dot to west of the number. Dip needle readings are shown in black. All are positive except those preceded by the negative sign. All readings show deviation of needles from the normal reading of the instrument used. Normal readings are omitted from the map except at each quarter section corner. All abnormal readings are shown.

Traverses were made on lines indicated—usually the N-S section and quarter lines. Dip needle readings were taken each 50 paces, dial compass readings each 100 paces when sun permitted.

Magnetic lines are indicated by heavy black lines, solid where definite and dashed where doubtful.

**CAUTION:** Almost any kind of rock may be the cause of magnetic attraction. Do not fail to read the following description of this township, and also chapter IV., in which the magnetic attractions are discussed.

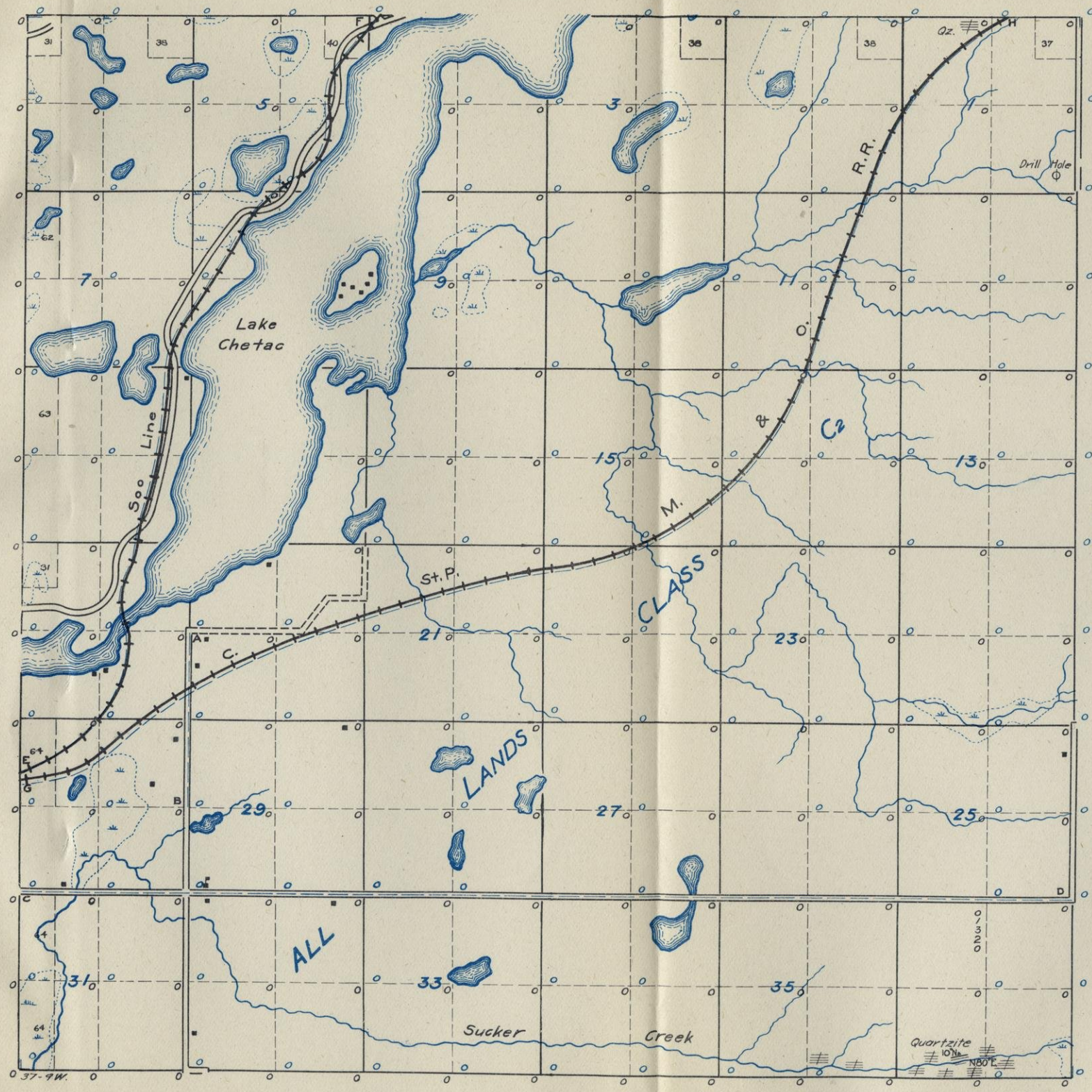

**PROFILES**

VERTICAL SCALE: 1 space = 20'  
HORIZONTAL SCALE: same as map

SEA LEVEL DATUM

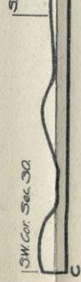
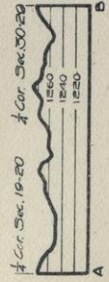
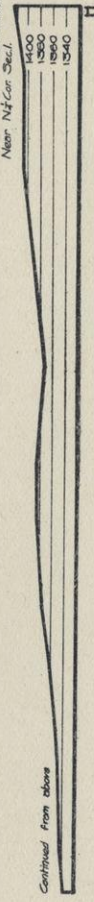
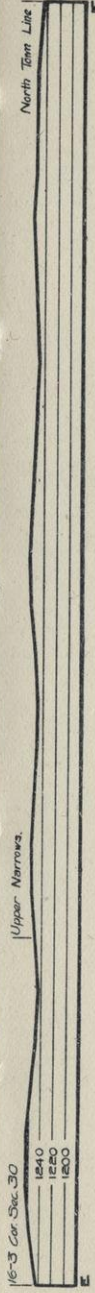
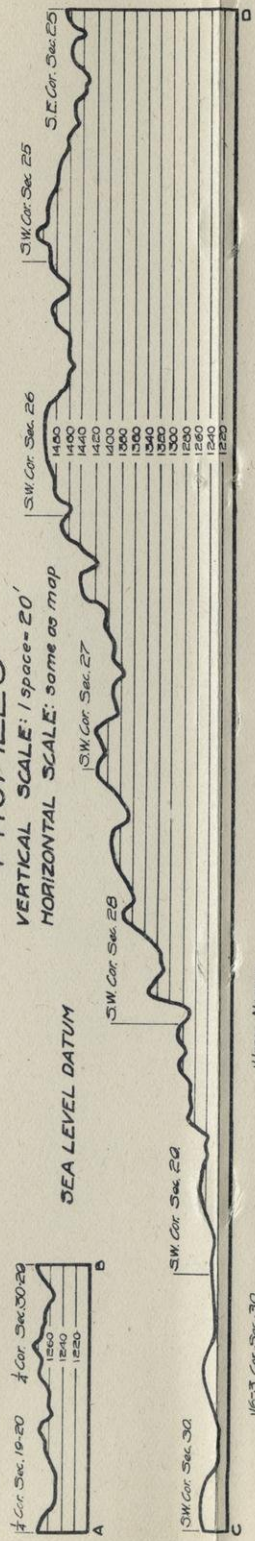

## TOWNSHIP 37 N., RANGE 10 W.

*Surface Features.*—This township has a markedly rough topography except very locally. The surface is characterized by steep knob-like hills alternating with small basins many of which are occupied by lakes with no outlets. The relief varies from 50 to 100 feet.

In the southeastern part a broad pre-glacial valley is occupied by Birch, Balsam, and Red Cedar lakes. These lakes generally have high steep banks and the topography in their immediate vicinity is rather rough. In the extreme southeastern part of the township the ground is high and rolling but is much less rugged than elsewhere. Section 33 and parts of the adjoining sections have a more gently undulating surface than most other parts of the township.

The profile A-B does not well illustrate the general character of the topography for the reason that it is taken on a road which follows a selected route and avoids the highest hills and deepest depressions.

Except in the vicinity of the village of Birchwood, the roads are poor. The drift is very gravelly, however, and the construction of good roads is not a difficult problem. The only timber remaining in this township consists of very small scattered patches of hardwood. Most of the original growth was pine, which was cut many years ago.

*Glacial Drift.*—Most of this township is covered by typical terminal moraine deposits. That portion lying east of the railroads in sections 25 and 36 is ground moraine and there is a small patch of this same type of deposit in sections 4 and 9. The drift is characteristically sandy and gravelly but the more level areas have a good covering of silt. Large bowlders are very common but as a rule are not numerous. In sections 33 and 34 there appears to be a few feet of clay near the surface, as shown by well records.

The depth of the drift over the greater part of the township is probably great. A number of wells have been drilled in the settled areas, two of which, in section 33, struck soft sandstone at a depth of about 100 feet. It is believed that at nearly all points the depth of surface will be in excess of this.

*General Geology.*—There are no outcrops of rock in this township. The two wells in the Cambrian sandstone and the fact that wells to the north and northeast also encounter this rock indicate that the entire township is probably underlain by sandstone. The

character of the older rocks beneath is entirely unknown, and since they are not exposed anywhere in the adjoining townships there is no basis for conjecture as to what they are.

*Magnetic Observations.*—No abnormal magnetic attraction was found.

*Land Classification.*—For a thorough understanding of the principles of land classification employed in this work the reader is referred to Chapter V. For lack of information as to the character of the underlying rocks all lands are placed in class C2.

*Exploration.*—Exploration for iron ore cannot be recommended in this township. While iron formation may exist beneath the sandstone, there is no indication of its presence and search for it by expensive exploration methods is not warranted.



TOWN 37 N., R. 10W.

Survey Made in August, 1914

Under the Direction of  
W. O. HOTCHKISS, State Geologist  
AND  
E. F. BEAN and O. W. WHEELI WRIGHT,  
in charge of Field Parties

BY  
R. W. CLARK, Chief of Party  
J. R. ROBERTS, Asst. Geologist  
W. G. CRAWFORD, Asst. Geologist

**SYMBOLS AND ABBREVIATIONS.**  
The symbols and abbreviations used on this map are explained in Chapter II.

**TOWN AND RANGE LINES.**  
In constructing this map the south line of the township was laid off as a true east west line. The other boundary lines were then laid off with the lengths shown on the Land Survey plat. Some of the maps are therefore incorrect in shape but this is necessary because definite facts are lacking. The acreage of part of the lots in the north and west tier of sections is shown to give a check on the distances in these sections.

**LOCATIONS.**  
All locations are based on pacing traverses from government land corners. In many cases these were not found and it was necessary to continue the traverse several miles without a check. Locations of certain features may therefore be somewhat wrong. In such cases the feature sought may best be located by its relation to a stream, swamp, lake, or other feature shown on the map.

**PROFILES.**  
The locations of the profiles are shown on the map by dashed blue lines with black letters at the ends. Railroad profiles were furnished by the companies and show elevations of the ground rather than track in most cases; others are from road surveys by the State Highway Commission; most of them are hand level lines made by this Survey. Wherever possible the elevations above sea level are given. These elevations vary from 1050 to 1770 feet. A local datum plane was necessarily assumed in some cases. These cases are identifiable by the fact that the base line is always numbered 0.

**LAND CLASSIFICATION.**  
This is shown on the map by the blue letters. It is explained in the following township description and at length in chapter V.

**MAGNETIC DATA.**  
Dial compass readings are shown in blue figures. Eastward declinations are shown with a dot to the east and westward with a dot to west of the number. Dip needle readings are shown in black. All are positive except those preceded by the negative sign. All readings show deviation of needles from the normal reading of the instrument used. Normal readings are omitted from the map except at each quarter section corner. All abnormal readings are shown.

Traverses were made on lines indicated—usually the N-S section and quarter lines. Dip needle readings were taken each 50 paces, dial compass readings each 100 paces when sun permitted.

Magnetic lines are indicated by heavy black lines, solid where definite and dashed where doubtful.

**CAUTION:** Almost any kind of rock may be the cause of magnetic attraction. Do not fail to read the following description of this township, and also chapter IV., in which the magnetic attractions are discussed.

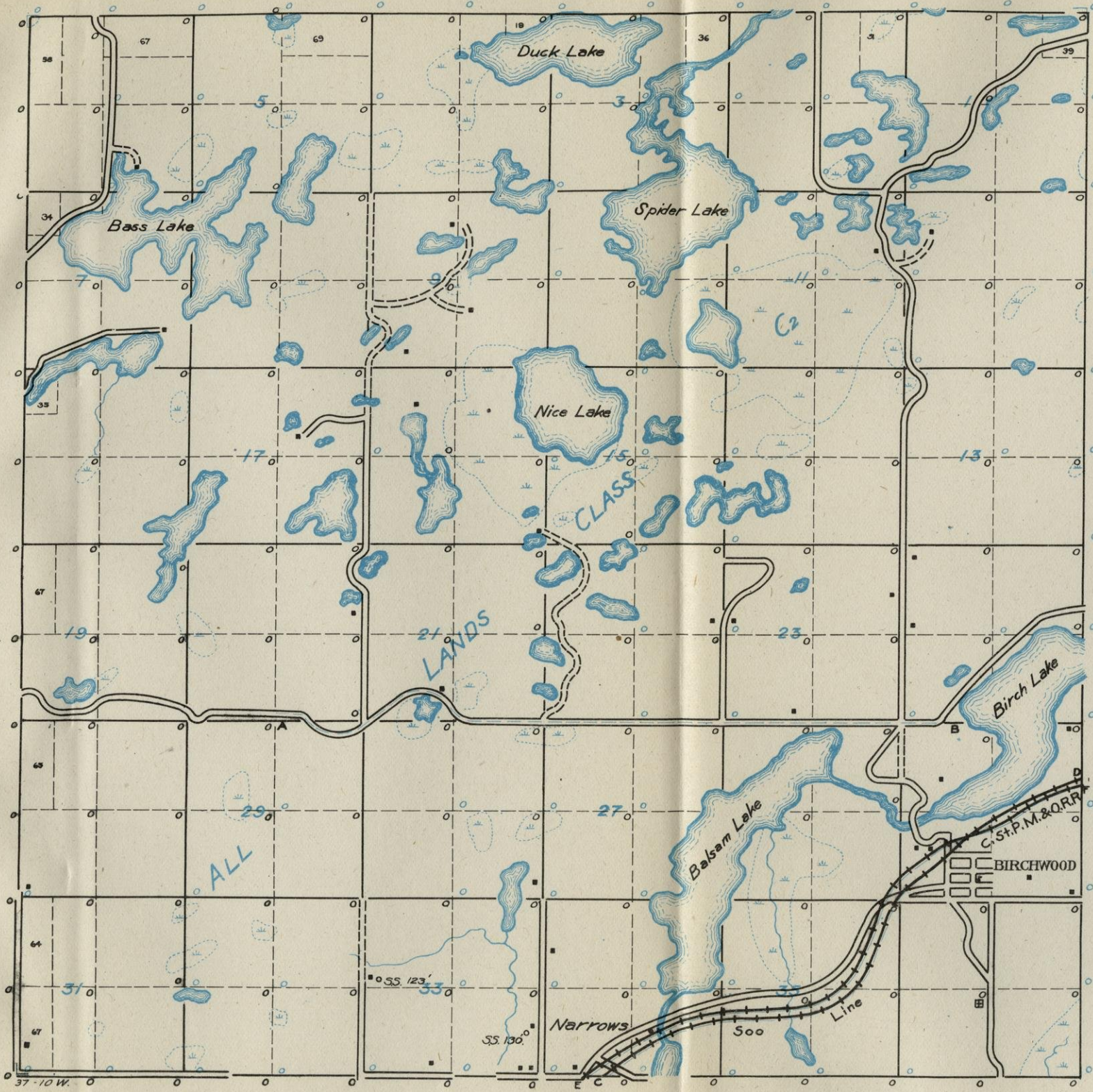

**PROFILE**

VERTICAL SCALE: 1 space = 20'  
HORIZONTAL SCALE: same as map

SEA LEVEL DATUM

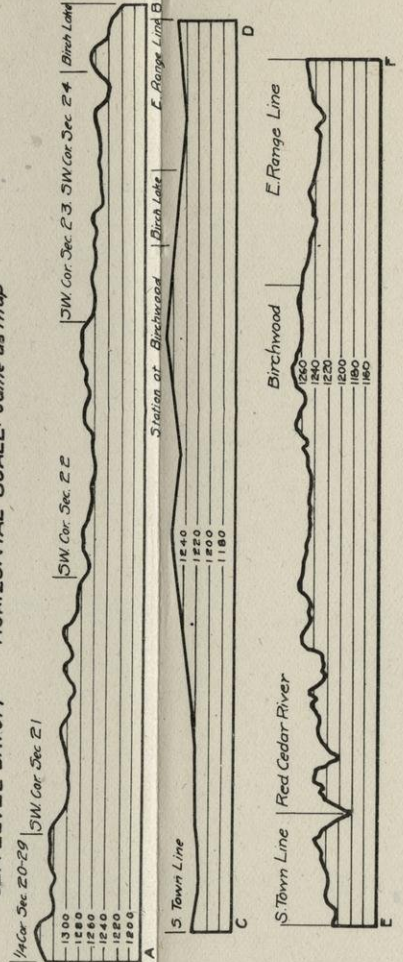

## TOWNSHIP 37 N., RANGE 11 W.

*Surface Features.*—Areas of rough topography occur west and southwest of Long Lake and along the east township line. The surface is very roughly undulating and depressions containing swamps and small undrained lakes are common. The relief is as great as 100 feet in places.

The north row of sections and the area inside the arms of Long Lake are likewise markedly undulating but the relief is much less than elsewhere. About two sections in the southwest corner and most of sections 26, 27, 34, and 35 have a rolling surface but slopes are rather gentle. A narrow strip along the Brill River is very flat. Long Lake is an interesting body of water lying in a steep sided valley with its sides rising as high as 100 feet above the lake in places. It is a part of a long chain of lakes extending northeast and southwest, which probably indicates the location of a pre-glacial drainage channel. The short profiles do not give much idea of the topography. Profile C-D shows the marked rise in elevation going away from Long Lake.

Roads are not numerous but are generally well graded and in good condition. Most of the timber has been removed but small patches of hardwood still remain.

*Glacial Drift.*—Most of the township is covered with drift deposited at the time of the last ice invasion but an area directly south of Long Lake shows older drift. This comprises the west half of section 25, all of sections 26, 34, and 35, the southeast half of sections 27 and 33, and nearly all of section 36. Part of this area is rather rough but slopes are gentle and the roughness is probably due largely to erosion. It is all ground moraine except the narrow valley through the center of sections 25 and 36 which is outwash. The drift in the ground moraine is composed of silt and sand with many clay seams beneath the surface. One well record seems to indicate that this clay is at least 100 feet deep in places. Boulders are not numerous. In the outwash area the drift is composed almost entirely of a very fine sand and silt. The latest drift is ground moraine in sections 30 and 31 and in places along the north township line. Elsewhere it is terminal moraine. The drift is sandy and gravelly with a silt covering. Boulders are numerous in but few places but are distributed generally over the township. Well records indicate that the latest drift does not cover the older drift to any great thickness along its edge.

The thickness of the drift is probably great in nearly all parts of the township. Two wells in section 33 penetrated sandstone at a depth of about 140 feet and it is probable that the drift is still thicker over most of the township. A possible exception is the hill in the northwest corner of section 4 which may be rock cored but the evidence is not conclusive.

*General Geology.*—There are no exposures of rock in this township. In the southwest corner of section 33 of the township to the north angular blocks of quartzite are found on a hillside, which suggests that the hill in section 4 may be underlain by the Barron quartzite. This is not certain, however. Two wells in section 33 were reported to have encountered Cambrian sandstone at a depth of about 140 feet and it is quite probable that this rock underlies all of the township. Of the older rocks underneath nothing is known.

*Magnetic Observations.*—No abnormal magnetic attraction was found.

*Land Classification.*—For a general discussion of the principles of land classification used in this work, the reader is referred to Chapter V. All lands in this township are placed in class C2 for the reason that iron formation is considered a possibility, but there is no indication of its presence.

*Exploration.*—Exploration for iron ore in this township cannot be recommended. While iron formation may underlie the sandstone in places it gives no indication of its presence, and an attempt to find it by drilling would offer little chance of success.

TOWN 37 N., R. 11W.

Survey Made in August, 1914

Under the Direction of

W. O. HOTCHKISS, State Geologist

AND

E. F. BEAN and O. W. WHEELWRIGHT,  
in charge of Field Parties

BY

R. W. CLARK, Chief of Party

J. R. ROBERTS, Asst. Geologist

W. E. HUBBARD, Asst. Geologist

**SYMBOLS AND ABBREVIATIONS.**

The symbols and abbreviations used on this map are explained in Chapter II.

**TOWN AND RANGE LINES.**

In constructing this map the south line of the township was laid off as a true east west line. The other boundary lines were then laid off with the lengths shown on the Land Survey plat. Some of the maps are therefore incorrect in shape but this is necessary because definite facts are lacking. The acreage of part of the lots in the north and west tier of sections is shown to give a check on the distances in these sections.

**LOCATIONS.**

All locations are based on pacing traverses from government land corners. In many cases these were not found and it was necessary to continue the traverse several miles without a check. Locations of certain features may therefore be somewhat wrong. In such cases the feature sought may best be located by its relation to a stream, swamp, lake, or other feature shown on the map.

**PROFILES.**

The locations of the profiles are shown on the map by dashed blue lines with black letters at the ends. Railroad profiles were furnished by the companies and show elevations of the ground rather than track in most cases; others are from road surveys by the State Highway Commission; most of them are hand level lines made by this Survey. Wherever possible the elevations above sea level are given. These elevations vary from 1050 to 1770 feet. A local datum plane was necessarily assumed in some cases. These cases are identifiable by the fact that the base line is always numbered 0.

**LAND CLASSIFICATION.**

This is shown on the map by the blue letters. It is explained in the following township description and at length in chapter V.

**MAGNETIC DATA.**

Dial compass readings are shown in blue figures. Eastward declinations are shown with a dot to the east and westward with a dot to west of the number. Dip needle readings are shown in black. All are positive except those preceded by the negative sign. All readings show deviation of needles from the normal reading of the instrument used. Normal readings are omitted from the map except at each quarter section corner. All abnormal readings are shown.

Traverses were made on lines indicated—usually the N-S section and quarter lines. Dip needle readings were taken each 50 paces, dial compass readings each 100 paces when sun permitted.

Magnetic lines are indicated by heavy black lines, solid where definite and dashed where doubtful.

**CAUTION:** Almost any kind of rock may be the cause of magnetic attraction. Do not fail to read the following description of this township, and also chapter IV., in which the magnetic attractions are discussed.

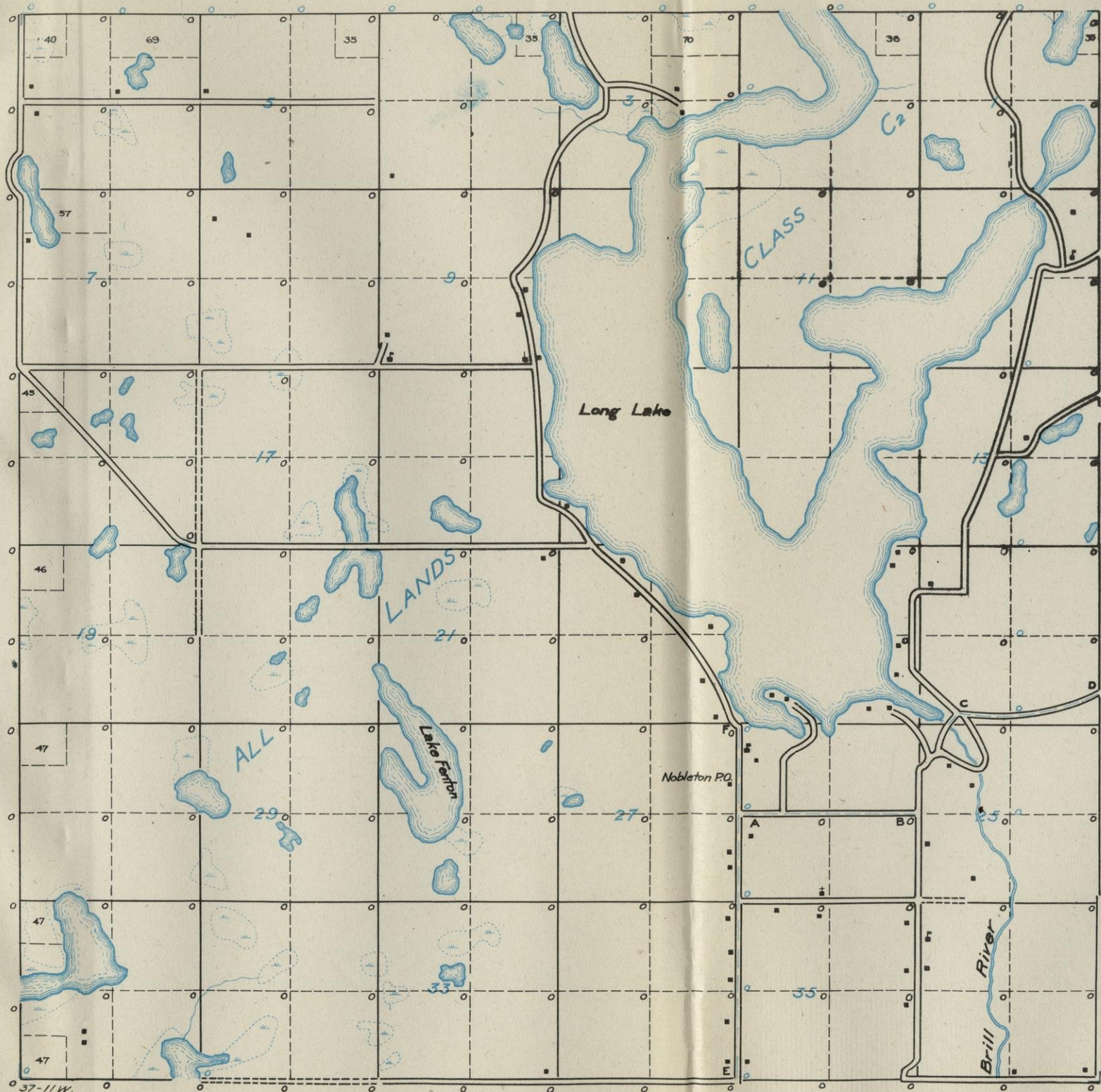

**PROFILE**  
VERTICAL SCALE: 1 space=50'  
HORIZONTAL SCALE: same as map

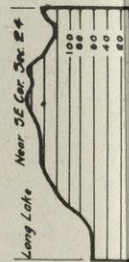
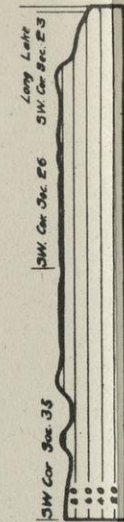

**LOCAL DATUM**

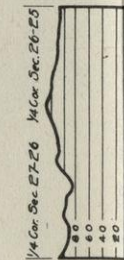

## TOWNSHIP 38 N., RANGE 6 E.

*Surface Features.*—The portion of the township surveyed, includes section 3, 4, 5, 6, 7, 8, 9, and 16 and a traverse along the C. M. & St. P. Ry. to the south township line. This part is characterized by very rugged topography, except a narrow strip in the north half of sections 6 and 5 and the area south of the swamp and north of the road in sections 7 and 18. The surface here is flat. In the rough area the slopes are steep and the relief is strong. Many large and small lakes occupy depressions in the drift. The profile shown on the township map gives a poor idea of the topography since it was made along a road following a winding course to avoid the elevations and depressions.

The roads in the township have been but little improved, but being in an open sand and gravel country are in fairly good shape for travel at all times. The original timber was almost entirely pine but none is left in that portion of the township surveyed.

*Glacial Drift.*—The level areas in sections 5, 6, 7, and 18 are out-wash plains. All the remainder of the country traversed is rugged terminal moraine. The drift consists of sand and gravel in the out-wash and sand, gravel and boulders in the terminal. Boulders are not present in large numbers as a rule.

The thickness of the drift is not known, but it is thought to be 100 feet or more in all parts of the township.

*General Geology.*—No exposures of rock were found. While the evidence is not conclusive, it is believed that the area is underlain by Huronian rocks probably very largely greenstones but the presence of sediments is also probable. While it cannot be stated positively that iron formation is absent, there is nothing to indicate its presence.

*Magnetic Observations.*—A general discussion of magnetic observations and their significance is given in Chapter IV. Practically all the traverses crossed areas in which mild abnormal dip needle readings were obtained. The attraction exists in broad indefinite areas and is not found in definite magnetic lines. This fact makes it appear quite probable that igneous rocks are the cause. Traverses made from Hazelhurst south on the railroad show mild attractions at several places, and it is considered quite likely that the greater part of the township will show such attractions.

*Land Classification.*—A general discussion of the principles of land classification employed in this work is given in Chapter V. All lands in the surveyed part of the township are placed in class C2.

*Exploration.*—The facts known do not warrant recommending exploration in the area surveyed. A complete magnetic survey of the remainder of the township may give further evidence that would warrant some work being done.

TOWN 38 N., R. 6E.

Survey Made in October, 1913

Under the Direction of  
W. O. HOTCHKISS, State Geologist  
AND  
E. F. BEAN and O. W. WHEELWRIGHT,  
in charge of Field Parties

BY  
E. F. BEAN, Chief of Party  
C. OLSON, Asst. Geologist

**SYMBOLS AND ABBREVIATIONS.**  
The symbols and abbreviations used on this map are explained in Chapter II.

**TOWN AND RANGE LINES.**  
In constructing this map the south line of the township was laid off as a true east west line. The other boundary lines were then laid off with the lengths shown on the Land Survey plat. Some of the maps are therefore incorrect in shape but this is necessary because definite facts are lacking. The acreage of part of the lots in the north and west tier of sections is shown to give a check on the distances in these sections.

**LOCATIONS.**  
All locations are based on pacing traverses from government land corners. In many cases these were not found and it was necessary to continue the traverse several miles without a check. Locations of certain features may therefore be somewhat wrong. In such cases the feature sought may best be located by its relation to a stream, swamp, lake, or other feature shown on the map.

**PROFILES.**  
The locations of the profiles are shown on the map by dashed blue lines with black letters at the ends. Railroad profiles were furnished by the companies and show elevations of the ground rather than track in most cases; others are from road surveys by the State Highway Commission; most of them are hand level lines made by this Survey. Wherever possible the elevations above sea level are given. These elevations vary from 1050 to 1770 feet. A local datum plane was necessarily assumed in some cases. These cases are identifiable by the fact that the base line is always numbered 0.

**LAND CLASSIFICATION.**  
This is shown on the map by the blue letters. It is explained in the following township description and at length in chapter V.

**MAGNETIC DATA.**  
Dial compass readings are shown in blue figures. Eastward declinations are shown with a dot to the east and westward with a dot to west of the number. Dip needle readings are shown in black. All are positive except those preceded by the negative sign. All readings show deviation of needles from the normal reading of the instrument used. Normal readings are omitted from the map except at each quarter section corner. All abnormal readings are shown.

Traverses were made on lines indicated—usually the N-S section and quarter lines. Dip needle readings were taken each 50 paces, dial compass readings each 100 paces when sun permitted.

Magnetic lines are indicated by heavy black lines, solid where definite and dashed where doubtful.

**CAUTION:** Almost any kind of rock may be the cause of magnetic attraction. Do not fail to read the following description of this township, and also chapter IV., in which the magnetic attractions are discussed.

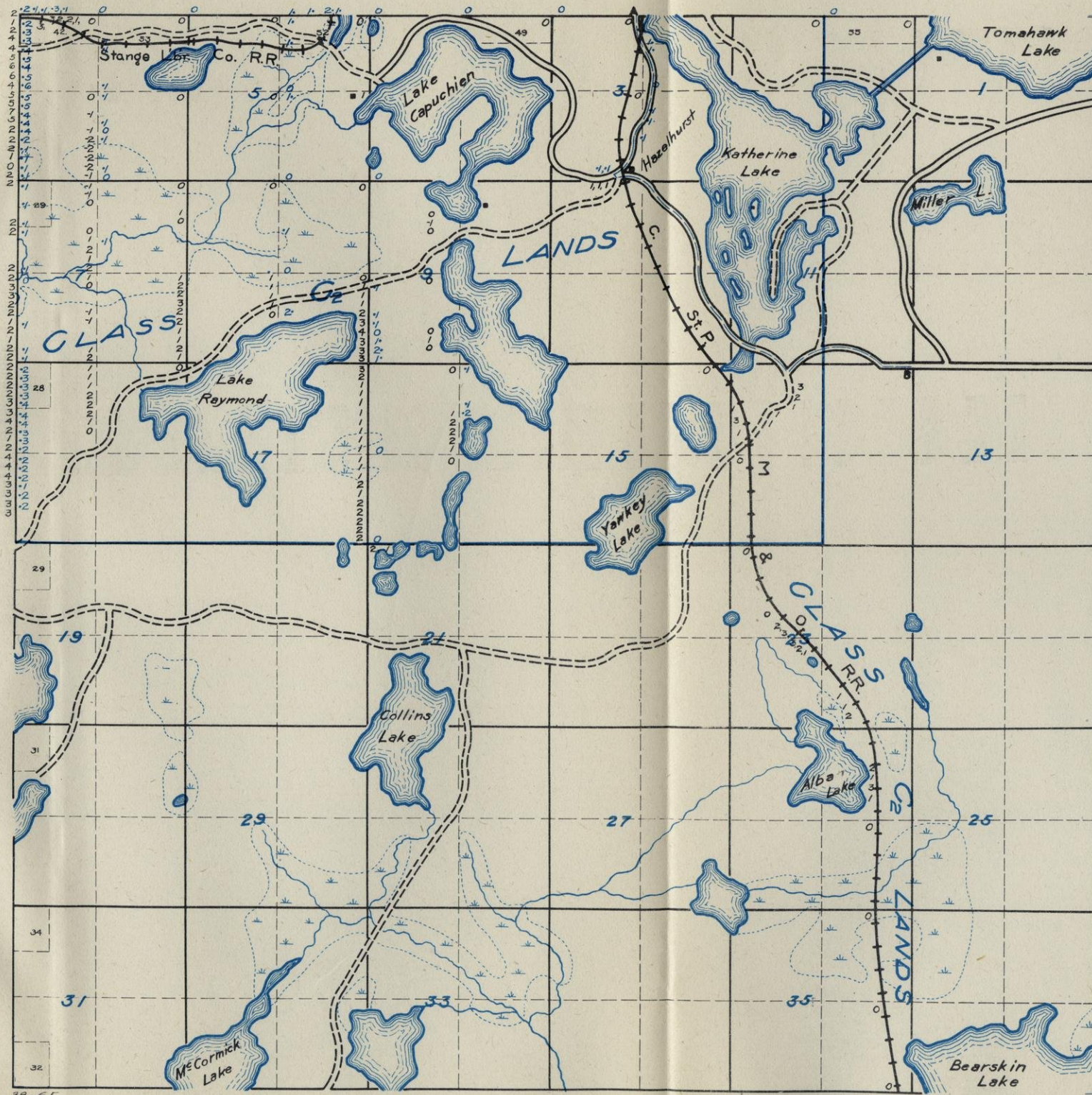

PROFILE

VERTICAL SCALE: 1 space = 20'  
HORIZONTAL SCALE: same as map

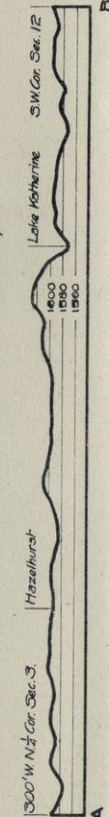

## TOWNSHIP 38 N., RANGE 5 E.

*Surface Features.*—The report covers only the northern two-thirds of the township, the remainder not having been surveyed. The surface for the most part is decidedly uneven but the relief is usually less than 75 feet. There are many swamps, most of them in small basins in the drift. A few small lakes also occupy drift depressions. An irregular strip of more level ground averaging about 1 mile wide trends east and west across the center of the township.

The roads are rough, ungraded, and little used, but are in fair condition for travel because of the sandy and gravelly nature of the country. Settlers are very few in number. Small amounts of mixed hardwood and hemlock are found in sections 2, 3, 7, 10, 15, and 23 and some pine timber remains in sections 15, 16, 19 and 22, but most of the valuable timber has been cut.

*Glacial Drift.*—The more level area in the central part consists of ground moraine deposits which are nearly covered by outwash. An outwash plain lies in the north half of section 1. In these areas the drift consists largely of sand and gravel but where the ground moraine is not covered by the outwash some bowlders are found. All of the remainder of that part of the township which was surveyed is terminal moraine. The drift here is also characteristically sandy and gravelly but bowlders are of common occurrence.

Rock is exposed in two places along the Tomahawk River from which it appears that the depth of the surface is not excessive but it will probably approach 100 feet in many parts of the township.

*General Geology.*—A short distance south of the point where the wagon road crosses the east line of section 10, is an outcrop showing a variety of rocks. On the north side is a thin seam of greenish rock which presents all the evidences of being a sedimentary formation, probably a metamorphosed tuffaceous slate. This is inter-bedded with an acid flow south of which is a green volcanic agglomerate. None of the formations are more than a few feet thick. The slate appears to strike about N. 70° W. and the volcanic agglomerate strikes about N. 45° W. Sediments and volcanics of this type, and showing similar relations, are of common occurrence in the Huronian formations of Michigan, and it appears quite likely that these rocks are of this age. Another exposure is found on the Tomahawk River in the N. E.  $\frac{1}{4}$  of section 27. The rock exposed consists of a very fine grained diorite and a volcanic agglomerate similar to that ex-



posed in section 10. Between these two outcrops are found many angular blocks of syenite with crystals varying from  $\frac{1}{4}$  to  $\frac{3}{8}$  of an inch in diameter. This rock is not exposed in position but it is probably intrusive into the greenstones.

The evidence obtained from these outcrops, the magnetic evidence and the evidence in the adjoining townships, all point to the fact that Huronian rocks underlie most if not all of this township. They may be very largely igneous, but it is probable that sedimentary formations are also present.

*Magnetic Observations.*—A general discussion of magnetic observations and their significance is given in Chapter IV. In all of the eastern part where traverses were run, broad magnetic areas were found, in which the dip needle showed continuous attractions varying from  $1^{\circ}$  to  $4^{\circ}$  and in places as high as  $7^{\circ}$ , but no distinct lines could be traced out. The character of this attraction is such as to lead to the belief that it is caused by greenstones rather than by sediments. In sections 5, 7, and 8 there is a suggestion of a mild line of attraction but it is too indefinite to be of particular importance.

*Land Classification.*—A general discussion of the principles of land classification employed in this work is given in Chapter V. All lands in the surveyed part of the township are placed in class C2.

*Exploration.*—The facts at hand do not warrant recommending exploration in the part of this township which was surveyed.

**TOWN 38 N., R. 5E.**

Survey Made in September, 1913

Under the Direction of

W. O. HOTCHKISS, State Geologist

AND

E. F. BEAN and O. W. WHEELWRIGHT,  
in charge of Field Parties

BY

E. F. BEAN, Chief of Party

J. O. BRYANT, Asst. Geologist

C. OLSON, Asst. Geologist

**SYMBOLS AND ABBREVIATIONS.**

The symbols and abbreviations used on this map are explained in Chapter II.

**TOWN AND RANGE LINES.**

In constructing this map the south line of the township was laid off as a true east west line. The other boundary lines were then laid off with the lengths shown on the Land Survey plat. Some of the maps are therefore incorrect in shape but this is necessary because definite facts are lacking. The acreage of part of the lots in the north and west tier of sections is shown to give a check on the distances in these sections.

**LOCATIONS.**

All locations are based on pacing traverses from government land corners. In many cases these were not found and it was necessary to continue the traverse several miles without a check. Locations of certain features may therefore be somewhat wrong. In such cases the feature sought may best be located by its relation to a stream, swamp, lake, or other feature shown on the map.

**PROFILES.**

The locations of the profiles are shown on the map by dashed blue lines with black letters at the ends. Railroad profiles were furnished by the companies and show elevations of the ground rather than track in most cases; others are from road surveys by the State Highway Commission: most of them are hand level lines made by this Survey. Wherever possible the elevations above sea level are given. These elevations vary from 1050 to 1770 feet. A local datum plane was necessarily assumed in some cases. These cases are identifiable by the fact that the base line is always numbered 0.

**LAND CLASSIFICATION.**

This is shown on the map by the blue letters. It is explained in the following township description and at length in chapter V.

**MAGNETIC DATA.**

Dial compass readings are shown in blue figures. Eastward declinations are shown with a dot to the east and westward with a dot to west of the number. Dip needle readings are shown in black. All are positive except those preceded by the negative sign. All readings show deviation of needles from the normal reading of the instrument used. Normal readings are omitted from the map except at each quarter section corner. All abnormal readings are shown.

Traverses were made on lines indicated—usually the N-S section and quarter lines. Dip needle readings were taken each 50 paces, dial compass readings each 100 paces when sun permitted.

Magnetic lines are indicated by heavy black lines, solid where definite and dashed where doubtful.

**CAUTION:** Almost any kind of rock may be the cause of magnetic attraction. Do not fail to read the following description of this township, and also chapter IV., in which the magnetic attractions are discussed.

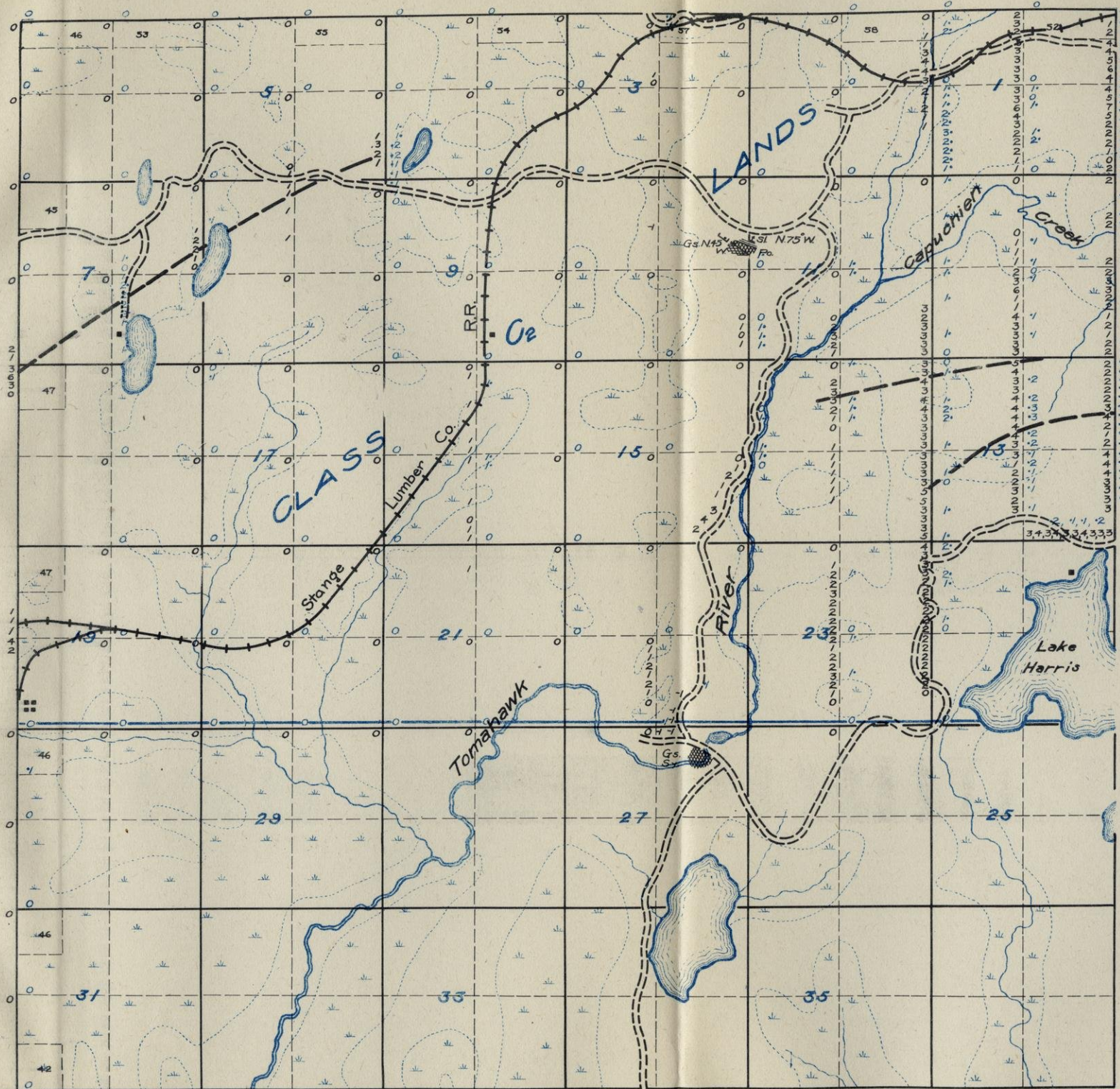

## TOWNSHIP 38 N., RANGE 4 E.

*Surface Features.*—The survey of sections 2 to 11 inclusive was not completed, so this report treats that part of the township only in a very general way. Approximately 50 percent of the surface is swamp or lake bottom. The topography of the higher parts of the township varies from that of the flat plain to very rugged knob and kettle topography. Many of the swamps also have gravelly hills protruding above the general level of the surface to a height of 20 to 40 feet.

An irregular area having a rough knob and basin topography occupies most of sections 13, 14, 23, and 24 and parts of all the adjoining sections. A similar irregular area occupies most of sections 21, 29 and 30, but here the surface is somewhat more even than in the area to the east. Section 36 and the east half of section 35 has a markedly undulating surface. That part of section 1 not in the swamp area has a rough surface. A rather prominent ridge trends along the west side of Long Lake in sections 33 and 34. Elsewhere the surface is but gently undulating and locally is very flat.

The roads shown on the map are old tote roads which are ungraded and rough but because of the sandy and gravelly nature of the country are fairly passable. Considerable timber remains uncut both on the high ground and in the swamps. The major portion is hemlock, although there is some hardwood and even small amounts of pine. There are no settlers in the township.

*Glacial Drift.*—All of the rougher areas above indicated are terminal moraine. A pronounced belt extends across the township from section 30 to 13, although it is very irregular in outline and is not continuous across 22. The east end is much wider and rougher than the west. Here the relief at times reaches as much as 100 feet. In the west the relief is usually less than 50 feet. The rough ground in sections 35 and 36 is also terminal moraine but is of the undulating rather than the knob and kettle type. Section 1 is also covered with terminal moraine deposits. Outwash is found between the moraines in sections 22 and 27 and over most of 15 and 16. The outwash surface is somewhat pitted but is generally quite level. Elsewhere the drift is ground moraine. Whether it be terminal moraine, ground moraine or outwash, the drift consists essentially of sand and gravel. Boulders are present in considerable quantities except in the outwash.

There is no information bearing on the depth of the surface, but it is assumed that it will be found to be more than 100 feet thick over most of the township.

*General Geology.*—No exposures of rock are found in that part of the township surveyed. The granite area is extended from the west by continuing the boundary in a direct line and also on the basis of the magnetic work. Most of section 6 and the north half of section 5 is probably underlain by this type of rock. The character of the underlying formations in the remainder of the township is not known, but it is believed that they are chiefly Huronian in age and consist in part at least of sedimentary formations.

*Magnetic Observations.*—A general discussion of magnetic observations and their significance is given in Chapter IV. Abnormal magnetic attractions are found rather generally over the southern half of the township but well defined magnetic lines are lacking. Attraction of this sort is suggestive of greenstones rather than of sediments. Similar attraction is found in the northern part but was crossed on only two traverses so that the extent of the area is somewhat doubtful. This also probably indicates the presence of greenstones.

*Land Classification.*—A general discussion of the principles of land classification employed in this work is given in Chapter V. All lands in this township are placed in class C2, although it is believed that granites and greenstones underlie a very large part of the township. The evidence is not, however, sufficient to warrant outlining definitely areas in which these rocks occur or excluding the possibility of iron formation from any considerable area.

*Exploration.*—Exploration in this township cannot be recommended on the information available.

# TOWN 38 N., R. 4E.

Survey Made in September, 1913

Under the Direction of

W. O. HOTCHKISS, State Geologist

AND

E. F. BEAN and O. W. WHEELWRIGHT,  
in charge of Field Parties

BY

H. H. BRADT, Chief of Party

J. O. BRYANT, Asst. Geologist

C. OLSON, Asst. Geologist

W. L. DOBIE, Asst. Geologist

## SYMBOLS AND ABBREVIATIONS.

The symbols and abbreviations used on this map are explained in Chapter II.

## TOWN AND RANGE LINES.

In constructing this map the south line of the township was laid off as a true east west line. The other boundary lines were then laid off with the lengths shown on the Land Survey plat. Some of the maps are therefore incorrect in shape but this is necessary because definite facts are lacking. The acreage of part of the lots in the north and west tier of sections is shown to give a check on the distances in these sections.

## LOCATIONS.

All locations are based on pacing traverses from government land corners. In many cases these were not found and it was necessary to continue the traverse several miles without a check. Locations of certain features may therefore be somewhat wrong. In such cases the feature sought may best be located by its relation to a stream, swamp, lake, or other feature shown on the map.

## PROFILES.

The locations of the profiles are shown on the map by dashed blue lines with black letters at the ends. Railroad profiles were furnished by the companies and show elevations of the ground rather than track in most cases; others are from road surveys by the State Highway Commission: most of them are hand level lines made by this Survey. Wherever possible the elevations above sea level are given. These elevations vary from 1050 to 1770 feet. These cases are necessarily assumed in some cases. These cases are identifiable by the fact that the base line is always numbered 0.

## LAND CLASSIFICATION.

This is shown on the map by the blue letters. It is explained in the following township description and at length in chapter V.

## MAGNETIC DATA.

Dial compass readings are shown in blue figures. Eastward declinations are shown with a dot to the east and westward with a dot to the west of the number. Dip needle readings are shown in black. All are positive except those preceded by the negative sign. All readings show deviation of needles from the normal reading of the instrument used. Normal readings are omitted from the map except at each quarter section corner. All abnormal readings are shown.

Traverses were made on lines indicated—usually the N-S section and quarter lines. Dip needle readings were taken each 50 paces, dial compass readings each 100 paces when sun permitted.

Magnetic lines are indicated by heavy black lines, solid where definite and dashed where doubtful.

**CAUTION:** Almost any kind of rock may be the cause of magnetic attraction. Do not fail to read the following description of this township, and also chapter IV., in which the magnetic attractions are discussed.

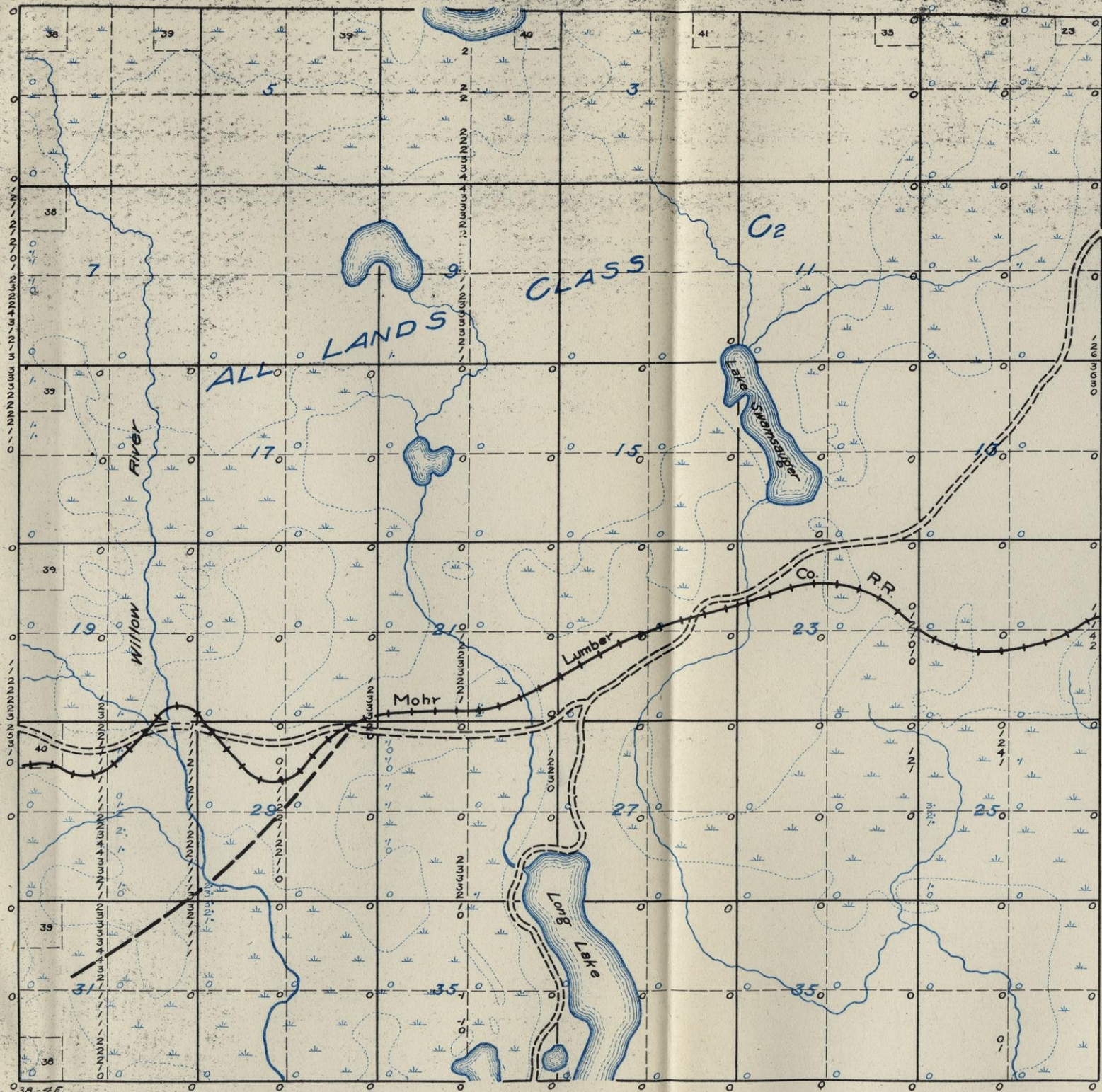

## TOWNSHIP 38 N., RANGE 3 E.

*Surface Features.*—The greater part of this township has a gently undulating surface with comparatively slight relief. The monotony is relieved by deep valleys along the Big Elk River and its tributaries in sections 8, 9, 16 and 17, and by three small areas of rough ground in sections 2 and 3. These latter areas show rough knob and basin topography, with a relief of 40 to 50 feet. The Big Elk occupies a valley about  $\frac{1}{2}$  mile wide with unusually high and steep sides, as shown by the profile. Along the road near the S.  $\frac{1}{4}$  S. of section 20 the drop is nearly 125 feet from the general level of the township. This valley is a pronounced feature in this township and for some 3 miles south in T. 37-3 E. Undoubtedly it was cut by a large stream in glacial times and the present Big Elk has inherited its valley. A side valley in section 29 and the valleys of the small streams in sections 8, 9, 16, and 17 also show steep slopes, although the banks are here very much lower than along the main stream. Abandoned valleys are also found in the south side of section 4 and the west side of section 12. No streams occupy these at present, and it is quite probable that they were formed by glacial streams, and were later abandoned when drainage became more settled. Away from the Big Elk drainage is poor and there are a number of large swamps.

The only road in the township crosses it from east to west 1 mile south of the center line. From the Elk River to Phillips it is good, but east of the river its condition is only fair. There is but one settler in the township. Large quantities of hemlock and hardwood remain uncut and a number of swamps have good stands of timber. Logging operations are active at the present time.

*Glacial Drift.*—Small areas of terminal moraine occur in the N.  $\frac{1}{2}$  and in the S. W.  $\frac{1}{4}$  of section 3, and the S. E.  $\frac{1}{4}$  of section 2. Elsewhere the glacial deposits are ground moraine. The drift in the terminal moraine areas consist principally of sand and gravel with a plentiful mixture of boulders. In the ground moraine areas sand and gravel compose a large part of the drift, but silt is the prominent constituent and clay is found in places. Boulders are very common.

In sections 6 and 7 large, angular granite boulders occur on the surface in such numbers as to suggest that the rock is not deeply buried. The thickness of the drift may be moderate in that part of the township but the evidence favors deep surface in the south half.

*General Geology.*—There are no rock exposures but granite boulders in section 6 suggest that the ledge is close to the surface in that part of the township. It is probable that most of the northern third of the township is underlain by granite. The character of the rocks in the remainder of the township is subject to doubt but they are believed to be Huronian in age and to consist in part of sedimentary formations. This conclusion is reached almost entirely as a result of magnetic work.

*Magnetic Observations.*—A general discussion of magnetic observations and their significance is given in Chapter IV. There is an area of moderately strong attraction in the west central part which continues for several miles in T. 38-2 E. Over part of its extent there appear to be two maxima. Although showing some irregularities the line appears to be caused by sedimentary formations, possibly iron formation. In section 12 and 13 there is a broad area of very mild attraction which is possibly continuous over much of the northern half of T. 38-4 E., although not traced out closely. Along the east line of sections 24 and 25 mild attraction indicates the western limit of an irregular magnetic area occurring in the township to the east.

*Land Classification.*—The principles of land classification employed in this work are discussed in Chapter V. Those lands in the magnetic area in the west central part are placed in class C1. All other lands in the township are placed in class C2. While it is quite certain that much of the northern part is underlain by granite the evidence is not absolutely conclusive so the D classification is not employed.

*Exploration.*—Exploration in this township cannot be especially recommended with the information at hand. However, the magnetic line in the western part is sufficiently regular to warrant doing some work to determine whether or not it is caused by iron formation.

**TOWN 38 N., R. 3E.**

Survey Made in September, 1913

Under the Direction of  
**W. O. HOTCHKISS, State Geologist**  
AND  
**E. F. BEAN and O. W. WHEELWRIGHT,**  
in charge of Field Parties

BY  
**R. W. CLARK, Chief of Party**  
**W. C. BEAN, Asst. Geologist**  
**E. T. HODGE, Asst. Geologist**

**SYMBOLS AND ABBREVIATIONS.**  
The symbols and abbreviations used on this map are explained in Chapter II.

**TOWN AND RANGE LINES.**  
In constructing this map the south line of the township was laid off as a true east west line. The other boundary lines were then laid off with the lengths shown on the Land Survey plat. Some of the maps are therefore incorrect in shape but this is necessary because definite facts are lacking. The acreage of part of the lots in the north and west tier of sections is shown to give a check on the distances in these sections.

**LOCATIONS.**  
All locations are based on pacing traverses from government land corners. In many cases these were not found and it was necessary to continue the traverse several miles without a check. Locations of certain features may therefore be somewhat wrong. In such cases the feature sought may best be located by its relation to a stream, swamp, lake, or other feature shown on the map.

**PROFILES.**  
The locations of the profiles are shown on the map by dashed blue lines with black letters at the ends. Railroad profiles were furnished by the companies and show elevations of the ground rather than track in most cases; others are from road surveys by the State Highway Commission: most of them are hand level lines made by this Survey. Wherever possible the elevations above sea level are given. These elevations vary from 1050 to 1770 feet. A local datum plane was necessarily assumed in some cases. These cases are identifiable by the fact that the base line is always numbered 0.

**LAND CLASSIFICATION.**  
This is shown on the map by the blue letters. It is explained in the following township description and at length in chapter V.

**MAGNETIC DATA.**  
Dial compass readings are shown in blue figures. Eastward declinations are shown with a dot to the east and westward with a dot to west of the number. Dip needle readings are shown in black. All are positive except those preceded by the negative sign. All readings show deviation of needles from the normal reading of the instrument used. Normal readings are omitted from the map except at each quarter section corner. All abnormal readings are shown.

Traverses were made on lines indicated—usually the N-S section and quarter lines. Dip needle readings were taken each 50 paces, dial compass readings each 100 paces when sun permitted.

Magnetic lines are indicated by heavy black lines, solid where definite and dashed where doubtful.

**CAUTION:** Almost any kind of rock may be the cause of magnetic attraction. Do not fail to read the following description of this township, and also chapter IV., in which the magnetic attractions are discussed.

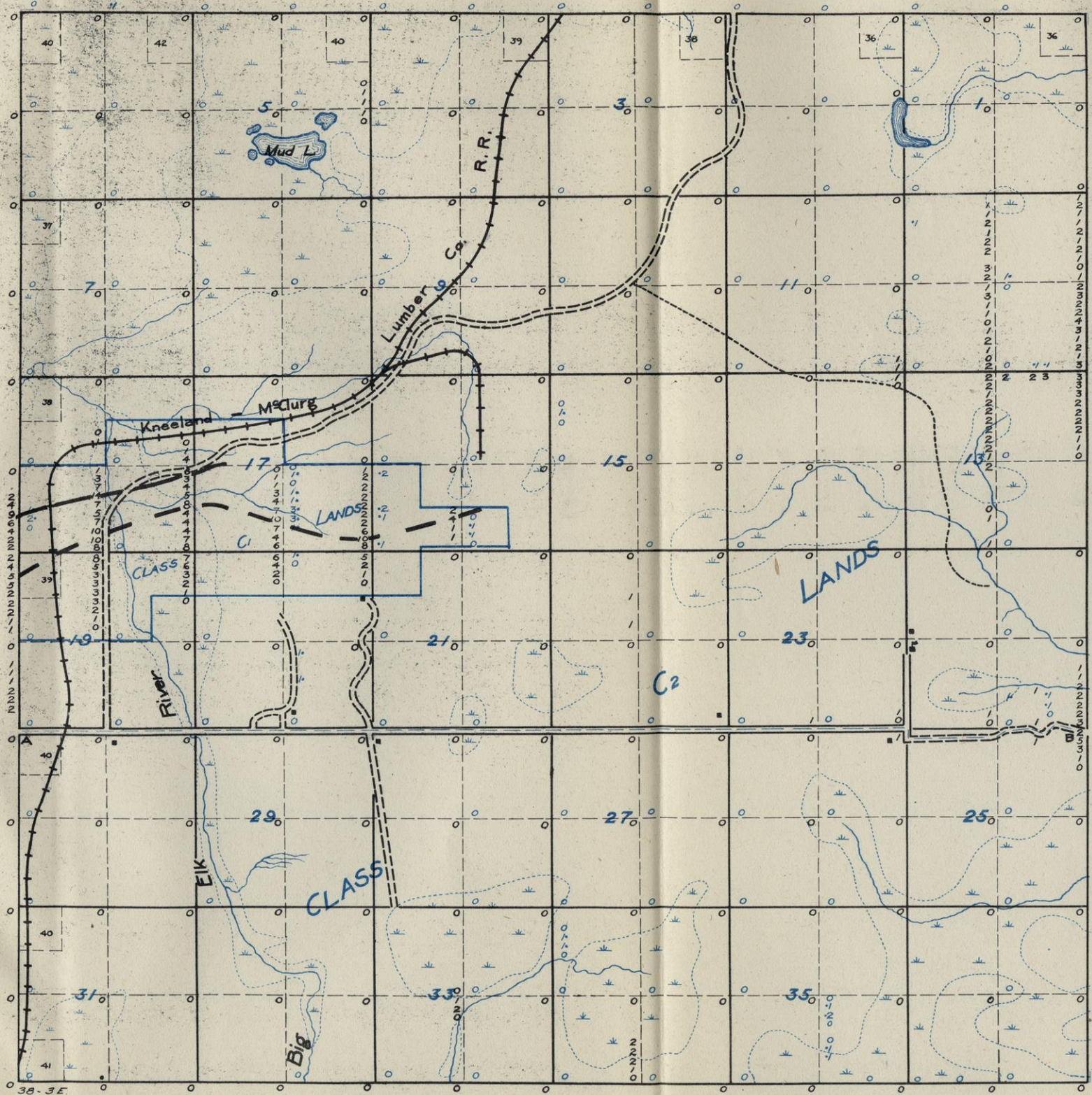

**PROFILE**

VERTICAL SCALE: 1 space = 20'  
HORIZONTAL SCALE: same as map

LOCAL DATUM





## TOWNSHIP 38 N., RANGE 2 E.

*Surface Features.*—The surface of this township is in general very gently undulating and the relief is slight. The drainage is poorly developed and there are a number of large swamps. Small areas of rougher ground occur in the north half of section 4 and the west half of 11, and in an area including most of sections 8 and 9, the south half of 7, the west half of 10, and the north half of 16 and 17. The topography here consists of a series of ridges in most places and in others of a succession of knobs and kettles with a relief of about 50 feet. The Big Elk River occupies a wide and rather prominent valley which is believed to have been formed by a more powerful glacial stream. There is a difference of elevation of about 100 feet between the east and west sides as shown by the profile A-B. This, as well as the profile E-F shows the wide valley of the Big Elk. Both profiles show a surface rather rougher than is the case for most of the township.

The main road crossing from east to west, and the one running south on the east line of section 28, are in good condition. The others are very little used and are passable with difficulty. The south central part of the township contains considerable hardwood and hemlock, and a large amount of burned over hardwood is standing in the southeastern part.

*Glacial Drift.*—The rougher areas in the north half, mentioned above, are poorly developed terminal moraine. The remainder of the township is covered by ground moraine deposits. The drift in the terminal moraine consists of sand and gravel with minor amounts of silt, and a large number of boulders. In the ground moraine the drift consists of silt with some sand and gravel, and boulders are also very numerous here. Some clay is also found in the ground moraine areas.

The depth of the drift varies considerably. In the north half there are a number of exposures of rock which indicate that it is not deep in this part of the township. The lower elevation of the west side may indicate the comparatively thin drift here, as well, but it is probably 100 feet deep or more in the southeastern part. A well 62 feet deep in section 35 failed to reach the ledge.

*General Geology.*—Near the northeast corner of section 1 is an exposure of fine-grained granite composed principally of feldspar and quartz, but containing some biotite. Several outcrops of granite

occur along the section line between 16 and 17 south of the quarter post. It is a pink biotite granite of varying texture. In places the feldspar crystals are as much as 1 inch in diameter. Similar granites occur at two points in section 8 as shown in the map. From the evidence obtained here and in adjoining townships it is believed that granite underlies most of the northern half of this township. There is no direct information bearing on the character of the rocks in the remaining part, but from the results of the magnetic work it is believed that they are largely sediments and greenstones of Huronian age.

*Magnetic Observations.*—A general discussion of magnetic observations and their significance is given in Chapter IV. No abnormal magnetic attraction was found in the northern half but nearly all of the remaining part of the township shows abnormal dip needle readings varying from  $1^{\circ}$  to  $15^{\circ}$ . There is a fairly definite line about 4 miles long extending from the southern part of section 13 to the center of section 28. In the east side it widens out to a broad area which is continuous for 2 miles in the township to the east. This may be caused by iron formation. Rather strong, but somewhat irregular attraction is found in the southwest corner. This resembles very much the attraction found in the hornblende schist area in T. 39-2E. The attractions in this township probably indicate Huronian rocks but except for the line in the east central part do not suggest iron formation.

*Land Classification.*—A general discussion of the principles of land classification employed in this work is given in chapter V. Lands upon which granites are found are placed in class D. Lands along the best defined line of attraction are placed in class C1. All others are placed in class C2, although all of the northern half possibly should be classed as D lands.

*Exploration.*—Exploration in this township is not to be strongly recommended until more geologic information is at hand. The southern third is in a large area thought to contain Huronian rocks and iron formations may be present. Undoubtedly the line extending from section 13 to 28 is the most favorable place to begin drilling. Much of the work done in exploration for iron ore is wasted because of failure to make intelligent use of the geologic and magnetic data to be obtained by a careful preliminary survey, and because the geologic information given by the drill is not properly used as a guide for further work. The value of careful scientific methods of explor-

TOWN 38 N., R. 2E.

Survey Made in August, 1913

Under the Direction of  
W. O. HOTCHKISS, State Geologist  
AND  
E. F. BEAN and O. W. WHEELWRIGHT,  
in charge of Field Parties

BY  
J. C. SCOLES, Chief of Party  
F. E. WILLIAMS, Asst. Geologist  
C. OLSON, Asst. Geologist  
E. T. HODGE, Asst. Geologist

**SYMBOLS AND ABBREVIATIONS.**  
The symbols and abbreviations used on this map are explained in Chapter II.

**TOWN AND RANGE LINES.**  
In constructing this map the south line of the township was laid off as a true east west line. The other boundary lines were then laid off with the lengths shown on the Land Survey plat. Some of the maps are therefore incorrect in shape but this is necessary because definite facts are lacking. The acreage of part of the lots in the north and west tier of sections is shown to give a check on the distances in these sections.

**LOCATIONS.**

All locations are based on pacing traverses from government land corners. In many cases these were not found and it was necessary to continue the traverse several miles without a check. Locations of certain features may therefore be somewhat wrong. In such cases the feature sought may best be located by its relation to a stream, swamp, lake, or other feature shown on the map.

**PROFILES.**

The locations of the profiles are shown on the map by dashed blue lines with black letters at the ends. Railroad profiles were furnished by the companies and show elevations of the ground rather than track in most cases; others are from road surveys by the State Highway Commission; most of them are hand level lines made by this Survey. Wherever possible the elevations above sea level are given. These elevations vary from 1050 to 1770 feet. A local datum plane was necessarily assumed in some cases. These cases are identifiable by the fact that the base line is always numbered 0.

**LAND CLASSIFICATION.**

This is shown on the map by the blue letters. It is explained in the following township description and at length in chapter V.

**MAGNETIC DATA.**

Dial compass readings are shown in blue figures. Eastward declinations are shown with a dot to the east and westward with a dot to the west of the number. Dip needle readings are shown in black. All are positive except those preceded by the negative sign. All readings show deviation of needles from the normal reading of the instrument used. Normal readings are omitted from the map except at each quarter section corner. All abnormal readings are shown.

Traverses were made on lines indicated—usually the N-S section and quarter lines. Dip needle readings were taken each 50 paces, dial compass readings each 100 paces when sun permitted.

Magnetic lines are indicated by heavy black lines, solid where definite and dashed where doubtful.

**CAUTION:** Almost any kind of rock may be the cause of magnetic attraction. Do not fail to read the following description of this township, and also chapter IV., in which the magnetic attractions are discussed.

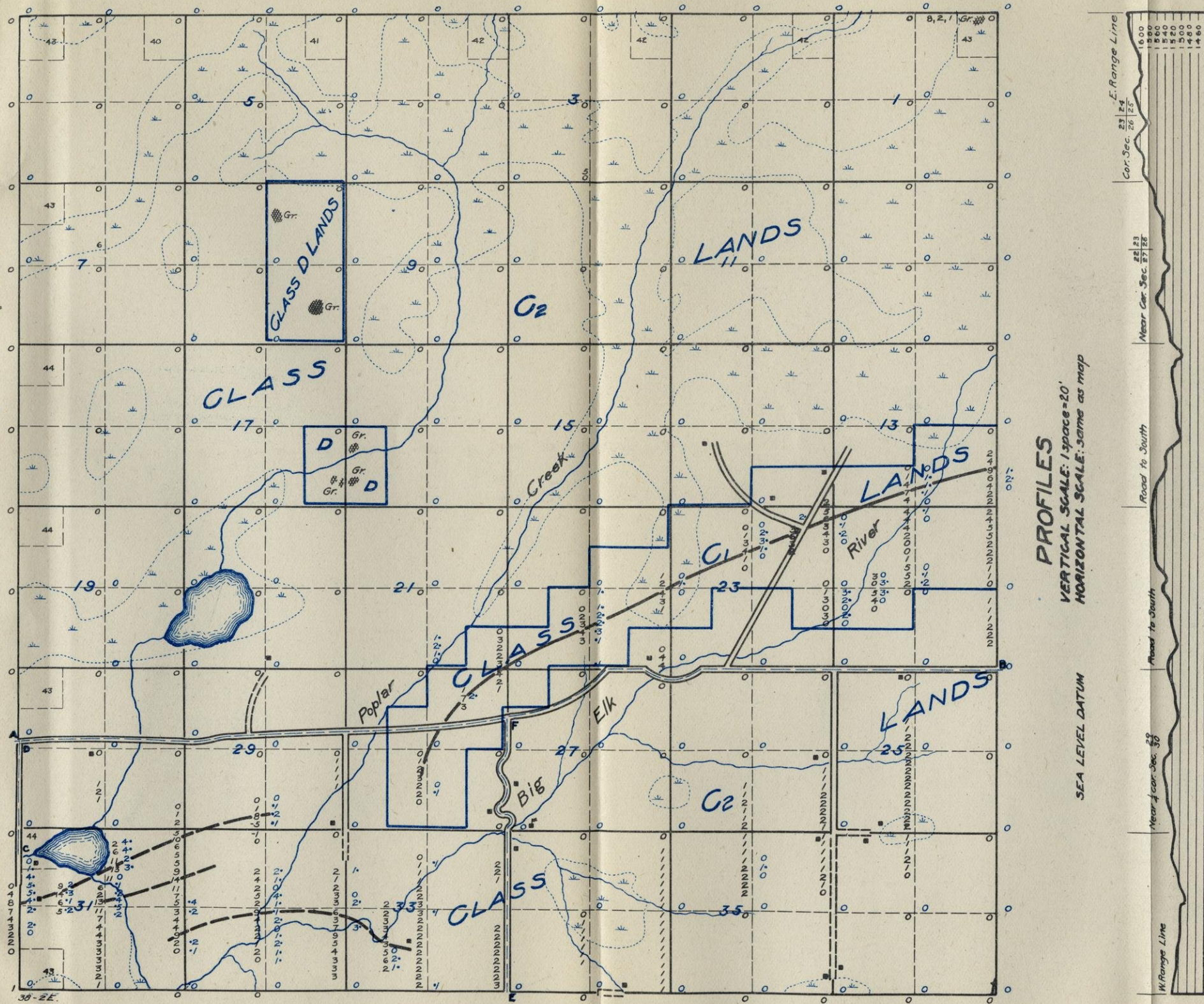

**PROFILES**  
VERTICAL SCALE: 1 space = 20'  
HORIZONTAL SCALE: same as map

SEA LEVEL DATUM

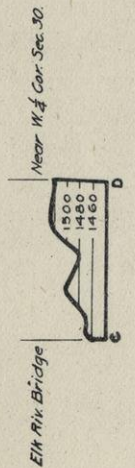
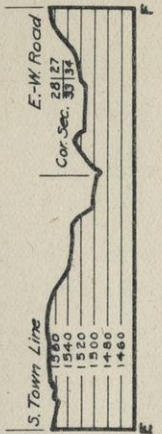

ation therefore cannot be **too strongly emphasized**. If exploration is contemplated in this township the **discussion** of this subject in Chapter VI should be **carefully studied**.

## TOWNSHIP 38 N., RANGE 4 W.

*Surface Features.*—Most of this township is characterized by gently undulating topography presenting no noteworthy features. Large areas of swamp are of common occurrence but are not of the kettle type and can readily be drained when economic conditions warrant it. The northwestern part is high and characterized by very pronounced hills having long smooth slopes. The local relief is 75 to 100 feet and the general elevation is about 150 feet above that of the railroad at Winter.

A single road leads into the township from Winter. It is fairly well graded and in good condition except during the wet seasons. Probably over 50 per cent of the township is still covered with forest growth consisting of hardwood and hemlock, but this is being rapidly removed. Settlers are very few and there are not over 100 acres of cleared land.

*Glacial Drift.*—The general elevation of the northwestern part is due to a terminal moraine, although lacking in many of the characteristics of this type of deposit. It is continuous to the west, north, and northwest in the adjoining townships and undoubtedly marks a considerable halt in the retreat of the glaciers. The remainder of the township is ground moraine upon which are superimposed small patches of outwash. The outwash occurs in sections 3, 4 and 5, in section 17, in section 32; and in section 36. The drift in the ground and terminal moraine areas consists of silt, sand, gravel and boulders. The boulders as a rule are not present in excessive quantities. The outwash consists of sand and gravel.

There is no information bearing on the thickness of the glacial drift but it is assumed to be great. It probably will be found to exceed 100 feet in most of the township.

*General Geology.*—There are no exposures of rock nor are there many in the adjoining townships so that evidence of the character of the underlying rocks is almost entirely lacking. From its general location and from the results of the magnetic work, it is thought, however, that this township is underlain largely by Huronian rocks.

*Magnetic Observations.*—A general discussion of magnetic observations and their significance is given in Chapter IV. Only very light attractions were encountered but there are two lines, one in section 10 and 11 and one extending from the S.  $\frac{1}{4}$  S. of 24 to the north half of 34 which are fairly definite. In the southeast corner

## TOWN 38 N., R. 4 W.

Survey Made in September, 1914

Under the Direction of

W. O. HOTCHKISS, State Geologist

AND

E. F. BEAN and O. W. WHEELWRIGHT,  
in charge of Field Parties

BY

H. J. ALLEN, Chief of Party

C. R. SCHROYER, Asst. Geologist

E. L. JAY, Asst. Geologist

### SYMBOLS AND ABBREVIATIONS.

The symbols and abbreviations used on this map are explained in Chapter II.

### TOWN AND RANGE LINES.

In constructing this map the south line of the township was laid off as a true east west line. The other boundary lines were then laid off with the lengths shown on the Land Survey plat. Some of the maps are therefore incorrect in shape but this is necessary because definite facts are lacking. The acreage of part of the lots in the north and west tier of sections is shown to give a check on the distances in these sections.

### LOCATIONS.

All locations are based on pacing traverses from government land corners. In many cases these were not found and it was necessary to continue the traverse several miles without a check. Locations of certain features may therefore be somewhat wrong. In such cases the feature sought may best be located by its relation to a stream, swamp, lake, or other feature shown on the map.

### PROFILES.

The locations of the profiles are shown on the map by dashed blue lines with black letters at the ends. Railroad profiles were furnished by the companies and show elevations of the ground rather than track in most cases; others are from road surveys by the State Highway Commission: most of them are hand level lines made by this Survey. Wherever possible the elevations above sea level are given. These elevations vary from 1050 to 1770 feet. A local datum plane was necessarily assumed in some cases. These cases are identifiable by the fact that the base line is always numbered 0.

### LAND CLASSIFICATION.

This is shown on the map by the blue letters. It is explained in the following township description and at length in chapter V.

### MAGNETIC DATA.

Dial compass readings are shown in blue figures. Eastward declinations are shown with a dot to the east and westward with a dot to west of the number. Dip needle readings are shown in black. All are positive except those preceded by the negative sign. All readings show deviation of needles from the normal reading of the instrument used. Normal readings are omitted from the map except at each quarter section corner. All abnormal readings are shown.

Traverses were made on lines indicated—usually the N-S section and quarter lines. Dip needle readings were taken each 50 paces, dial compass readings each 100 paces when sun permitted.

Magnetic lines are indicated by heavy black lines, solid where definite and dashed where doubtful.

CAUTION: Almost any kind of rock may be the cause of magnetic attraction. Do not fail to read the following description of this township, and also chapter IV., in which the magnetic attractions are discussed.

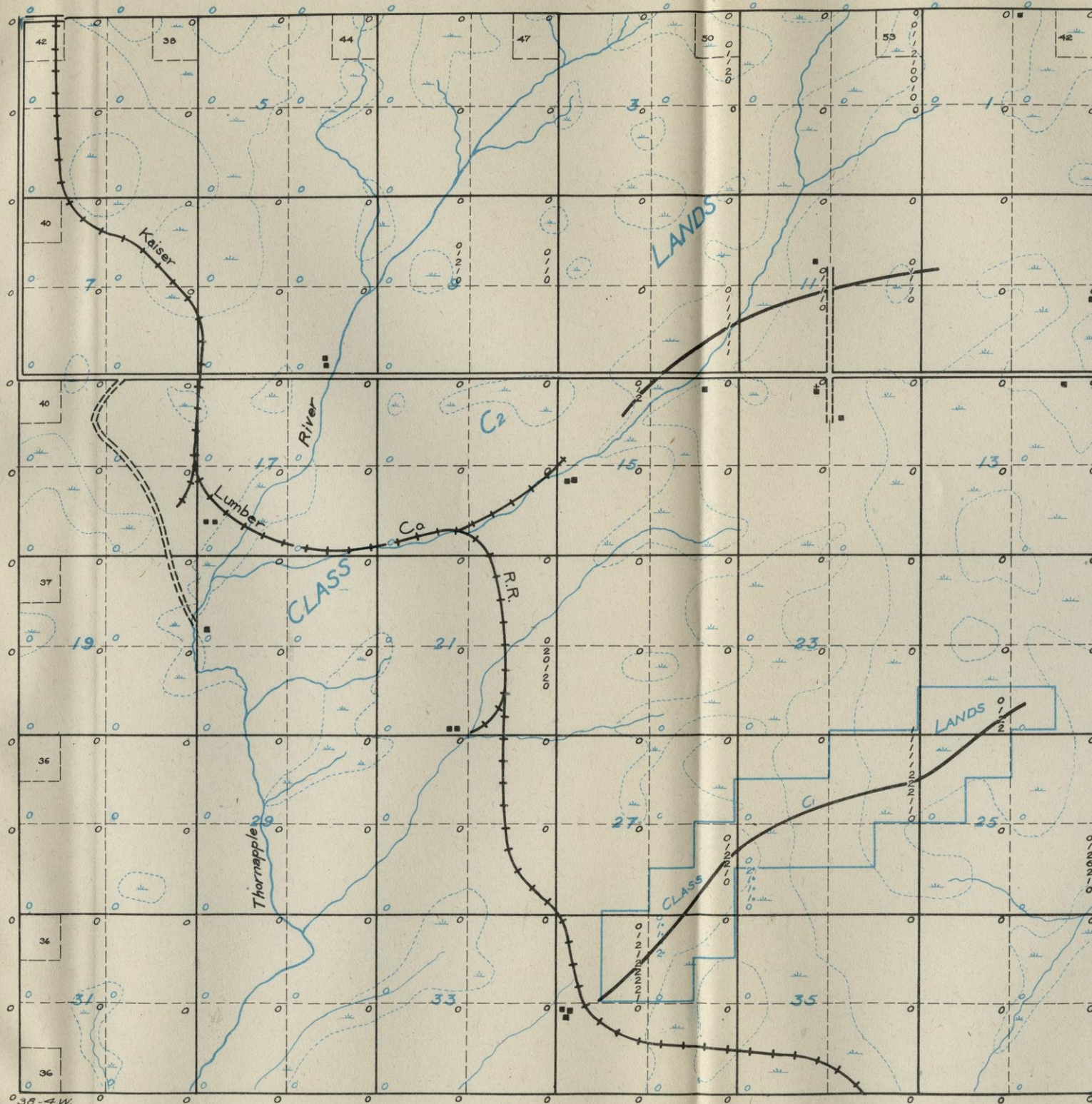

of section 25 some moderate attraction was encountered which may be continuous to the east. This township is on the strike of the lines found to the east in T. 39-2 and 3 W., and to the west in T. 37-6 and 7 W., and T. 36-7 and 8 W., and the cause of the attraction here is probably the same as in those townships. Deeper burial may make it less easily detected. These magnetic lines possibly indicate iron formation but this cannot be stated positively.

*Land Classification.*—A discussion of the principles of land classification employed in this work is given in Chapter V. Lack of geologic evidence makes it impossible to definitely classify these lands. Since iron formation is a possibility all are placed in class C2, except those in the best defined magnetic line in sections 24, 25, 26, 27 and 33, which are classed as C1 lands.

*Exploration.*—The mild magnetic attractions found in this township undoubtedly deserve some attention. They are part of a series of nearly continuous lines over 40 miles long, which fact strongly indicates that they may be caused by iron formation. The line from section 24 to 34 is probably the best to explore. Much of the work done in exploration for iron ore is wasted because of failure to make intelligent use of the geologic and magnetic data to be obtained by a careful preliminary survey, and because the geologic information given by the drill is not properly used as a guide for further work. The value of careful scientific methods of exploration therefore cannot be too strongly emphasized. If exploration is contemplated in this township the discussion of this subject in Chapter VI should be carefully studied.

## TOWNSHIP 38 N., RANGE 5 W.

*Surface Features.*—The entire township is characterized by moderately undulating topography which shows little variation in different parts. The relief is low except in the extreme northeastern part of the township, where it may reach as much as 100 feet. Even here slopes are gentle. The Brunet River has cut rather deeply into the drift in places so that the surface has a rugged appearance where this stream flows through the higher areas.

The profile A-B, drawn along some of the higher ground in the northern part of the township, shows the general lack of relief and to some extent the effects of the stream erosion. There is but one road in this township and this an old tote road which is practically impassable at all times. There are no settlers although the soil is good and the northern part is but 1 mile from a railroad town. Lack of roads is probably the cause for the failure to clear up the land.

*Glacial Drift.*—Most of the township is covered by ground moraine deposits, but there are some poorly defined areas of very weak terminal moraine. One of these extends across the northern part of the township through sections 1 to 5, another from sections 11 to 18, in a very broken manner, and a third extends from section 24 to the southwest corner of the township. The terminal moraine areas are somewhat more undulating and better drained but otherwise differ in no particular from the flatter ground moraine. The glacial drift is composed of silt and sand, with some gravel. Bowlders are very numerous in places.

*General Geology.*—Two outcrops of granite are found along the Brunet River. One occurs just below Price dam at the north half of section 9 and consists of a light gray biotite granite gneiss with feldspar crystals varying up to 1 inch in length. The exposure is very low and covered by the water during flood stages. Three hundred paces south of the northeast corner of section 19 another very low outcrop of granite occurs. It is grayish to pinkish granite gneiss somewhat coarser than that found in section 9. Feldspars as much as 3 inches in length were observed at this exposure. Biotite is a prominent constituent. The schistosity appears to strike nearly north and south. The granite in both of these exposures bears considerable resemblance to that in township 38-6 and 7 W. These few exposures do not give an adequate idea of the character of the underlying rock for the whole township, but judging from



TOWN 38 N., R. 5W.

Survey Made in June, 1914

Under the Direction of  
W. O. HOTCHKISS, State Geologist  
AND  
E. F. BEAN and O. W. WHEELWRIGHT,  
in charge of Field Parties

BY  
H. L. ALLEN, Chief of Party  
C. R. SCHROYER, Asst. Geologist  
E. L. JAY, Asst. Geologist

**SYMBOLS AND ABBREVIATIONS.**  
The symbols and abbreviations used on this map are explained in Chapter II.

**TOWN AND RANGE LINES.**  
In constructing this map the south line of the township was laid off as a true east west line. The other boundary lines were then laid off with the lengths shown on the Land Survey plat. Some of the maps are therefore incorrect in shape but this is necessary because definite facts are lacking. The acreage of part of the lots in the north and west tier of sections is shown to give a check on the distances in these sections.

**LOCATIONS.**  
All locations are based on pacing traverses from government land corners. In many cases these were not found and it was necessary to continue the traverse several miles without a check. Locations of certain features may therefore be somewhat wrong. In such cases the feature sought may best be located by its relation to a stream, swamp, lake, or other feature shown on the map.

**PROFILES.**  
The locations of the profiles are shown on the map by dashed blue lines with black letters at the ends. Railroad profiles were furnished by the companies and show elevations of the ground rather than track in most cases; others are from road surveys by the State Highway Commission; most of them are hand level lines made by this Survey. Wherever possible the elevations above sea level are given. These elevations vary from 1050 to 1770 feet. A local datum plane was necessarily assumed in some cases. These cases are identifiable by the fact that the base line is always numbered 0.

**LAND CLASSIFICATION.**  
This is shown on the map by the blue letters. It is explained in the following township description and at length in chapter V.

**MAGNETIC DATA.**  
Dial compass readings are shown in blue figures. Eastward declinations are shown with a dot to the east and westward with a dot to west of the number. Dip needle readings are shown in black. All are positive except those preceded by the negative sign. All readings show deviation of needles from the normal reading of the instrument used. Normal readings are omitted from the map except at each quarter section corner. All abnormal readings are shown.

Traverses were made on lines indicated—usually the N-S section and quarter lines. Dip needle readings were taken each 50 paces, dial compass readings each 100 paces when sun permitted.

Magnetic lines are indicated by heavy black lines, solid where definite and dashed where doubtful.

**CAUTION:** Almost any kind of rock may be the cause of magnetic attraction. Do not fail to read the following description of this township, and also chapter IV., in which the magnetic attractions are discussed.

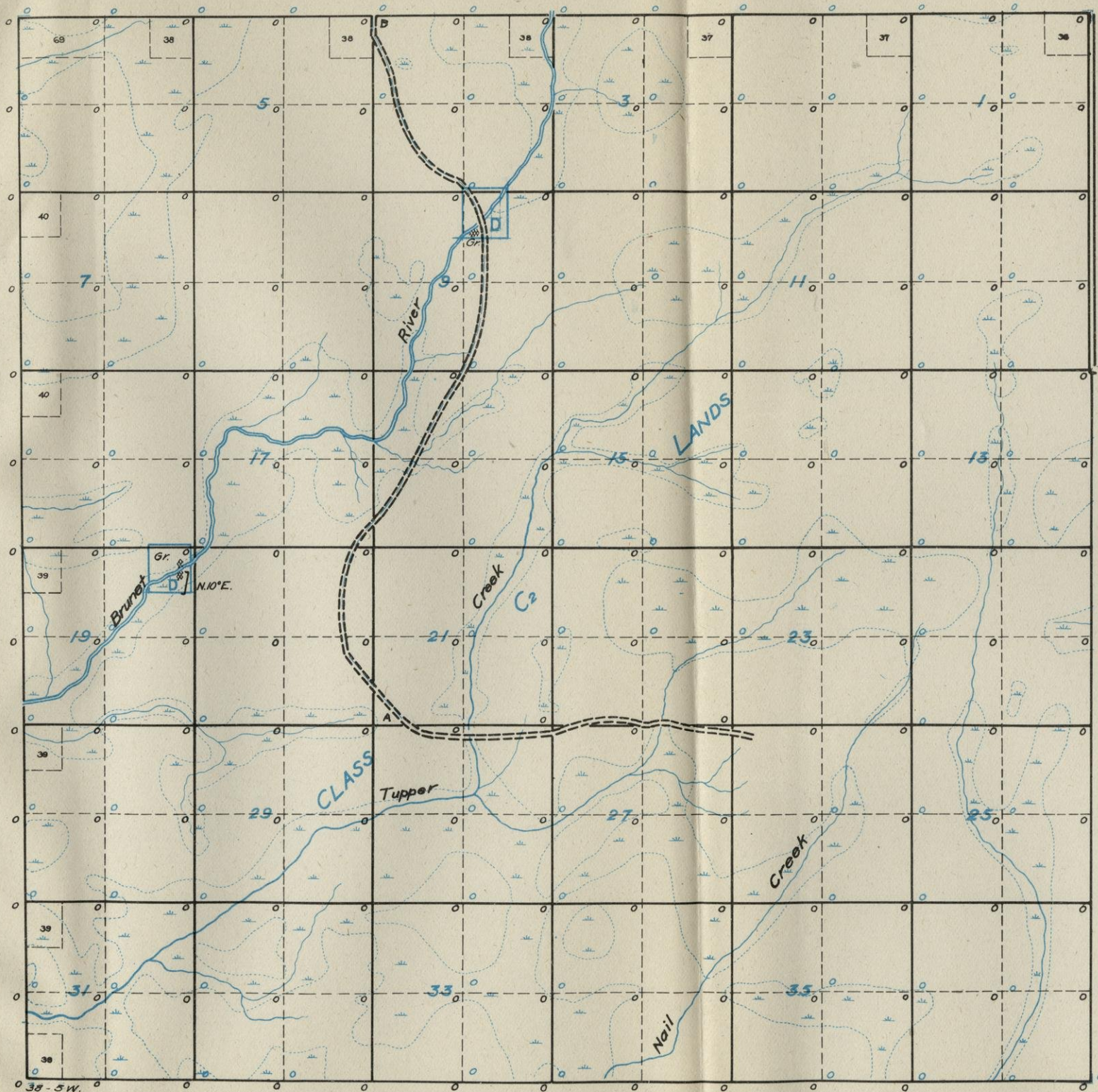

**PROFILE**

VERTICAL SCALE: 1 space = 20'.  
HORIZONTAL SCALE: same as map.

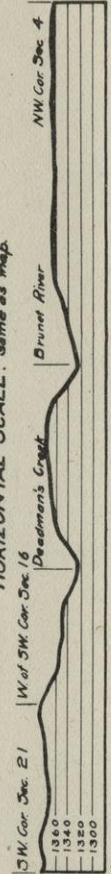

conditions to the east and west it is thought quite likely that granite is the principal underlying rock. The southeastern quarter is believed to be underlain by Huronian rocks.

*Magnetic Observations.*—No abnormal magnetic attractions were found in this township.

*Land Classification.*—For a general discussion of the principles of land classification employed in this work the reader is referred to Chapter V. The lands on which granite outcrops occur have been placed on class D. All others are classed as C2, although they are considered among the most unfavorably located lands of this class.

*Exploration.*—Exploration in this township is not recommended. Later developments may make it appear advisable to do some work in the southeastern part but until greater knowledge of the geology is obtained this is not advisable.

## TOWNSHIP 38 N., RANGE 6 W.

*Surface Features.*—This township is characterized by a flat or gently undulating surface except along the major streams and in a small area in sections 28, 33, and 34 and the west side of section 35. This latter area is somewhat higher and slightly rougher than the remainder but even here the relief is slight. The Chippewa River, flowing across the northern part, has cut deeply into the drift and its narrow valley is usually about 75 feet below the general level of the township. The erosion effects of the Brunet are less pronounced.

The profile of the C. St. P. M. & O. railroad, A-B, follows close to the river most of the way across the township, and so it does not give a good idea of the topography. The railroad leaves the river in the east side and ascends to higher ground. Here the profile gives an idea of the difference in elevations between the township as a whole and the valley of the river.

The roads in this township are few and usually poor. The main route of travel is the old Chippewa River road which follows along the sandy ground close to this stream and is generally in fair condition. Nearly all of the timber has been removed, but scattered areas of hardwood remain in various places. There are few settlers in the township.

*Glacial Drift.*—The somewhat elevated area in sections 28, 33, 34, and 35 is classed as terminal moraine because of its general elevation above the surrounding country rather than because it presents marked terminal characteristics. A narrow strip of outwash is found in sections 20, 29 and 30, widening out along the township line. The remainder of the township is covered with typical ground moraine deposits. Materials comprising the drift are silt, gravel, boulders and some sand in the ground and terminal moraines, and stratified sands and gravels in the outwash area. The drift in the valley of the Chippewa River is very sandy.

The thickness of the drift is not believed to be great since the main streams have cut through to the rock and the general topographic conditions do not indicate great depth of surface. It is probably less than 100 feet in all parts of the township.

*General Geology.*—Rocks are exposed along the Chippewa and Brunet rivers. On the west side of the Chippewa River at the point where the C. St. P. M. & O. railroad crosses is an outcrop about 400 paces long composed in part of a coarse diorite and in part of rather

fine grained granite gneiss. The **diorite** consists principally of plagioclase feldspar and hornblende crystals varying in size up to  $\frac{1}{2}$  inch in length. The composition of **this rock** varies somewhat in different places. It is apparently intruded by the granite gneiss which varies from a white very schistose rock with feldspar crystals nearly a half inch long to a very fine grained gneiss of grayish color. Both these types of gneiss contain considerable biotite. A half mile south along the stream is a very small outcrop of coarse pink pegmatite. On the banks of the river a few hundred paces south of the center of section 7 is an outcrop of pink granite of varying texture. Typically the rock consists of small crystals of quartz and feldspar about  $\frac{1}{8}$  inch in length, but in places it is so coarse as to deserve the name of pegmatite. Gneissic structure is poorly developed here.

Where the Chippewa River crosses the west township line in section 18 another outcrop of biotite granite gneiss is found which, however, lies principally in the township to the west and is described in the report of that township. Near the center of section 25 the Brunet River has exposed an outcrop about 400 paces long which consists of a pinkish hornblende biotite granite gneiss. The texture is medium grained with feldspars of  $\frac{1}{2}$  inch or more in length scattered through the rock. This rock does not differ from that found in T. 38-5 W., nor from that in the vicinity of Radisson dam, and all except the extreme northwestern part of this township appears to be in a large granite area as shown on the map, plate I. It is believed that Huronian rocks may underlie the northwestern part.

*Magnetic Observations.*—A general discussion of magnetic observations and their significance is given in Chapter IV. Irregular, mild, positive and negative variations of the dip needle were found distributed generally over this township, but except in the northwestern part they cannot be connected up into magnetic lines nor do they form well defined areas of attraction. The attraction in sections 5 and 6 is somewhat stronger and shows an indefinite line which continues northeast into T. 39-6 W. This may be caused by sedimentary rocks. The other attractions are believed to be caused by igneous rocks.

*Land Classification.*—The principles of land classification employed in this work are discussed in Chapter V. Lands on or near the magnetic line in sections 4, 5, and 6 are classed as C1 although considered among the least promising lands of this class. Those lands in the immediate vicinity of the outcropping igneous rocks are placed in class D. All others are classed as C2 although believed

to be underlain by granite. Since this is not certain the more definite D classification is not employed.

*Exploration.*—Exploration in this township is not recommended. Future developments may make it appear advisable to do some work on the class C1 lands but with the facts at hand this cannot be recommended.

TOWN 38 N., R. 6 W.

Survey Made in August, 1914

Under the Direction of  
W. O. HOTCHKISS, State Geologist  
AND  
E. F. BEAN and O. W. WHEELWRIGHT,  
in charge of Field Parties

BY  
W. C. BEAN, Chief of Party  
G. S. NISHIHARA, Asst. Geologist  
HOWARD QUINLAN, Asst. Geologist

**SYMBOLS AND ABBREVIATIONS.**  
The symbols and abbreviations used on this map are explained in Chapter II.

**TOWN AND RANGE LINES.**  
In constructing this map the south line of the township was laid off as a true east west line. The other boundary lines were then laid off with the lengths shown on the Land Survey plat. Some of the maps are therefore incorrect in shape but this is necessary because definite facts are lacking. The acreage of part of the lots in the north and west tier of sections is shown to give a check on the distances in these sections.

**LOCATIONS.**  
All locations are based on pacing traverses from government land corners. In many cases these were not found and it was necessary to continue the traverse several miles without a check. Locations of certain features may therefore be somewhat wrong. In such cases the feature sought may best be located by its relation to a stream, swamp, lake, or other feature shown on the map.

**PROFILES.**  
The locations of the profiles are shown on the map by dashed blue lines with black letters at the ends. Railroad profiles were furnished by the companies and show elevations of the ground rather than track in most cases; others are from road surveys by the State Highway Commission: most of them are hand level lines made by this Survey. Wherever possible the elevations above sea level are given. These elevations vary from 1050 to 1770 feet. A local datum plane was necessarily assumed in some cases. These cases are identifiable by the fact that the base line is always numbered 0.

**LAND CLASSIFICATION.**  
This is shown on the map by the blue letters. It is explained in the following township description and at length in chapter V.

**MAGNETIC DATA.**  
Dial compass readings are shown in blue figures. Eastward declinations are shown with a dot to the east and westward with a dot to west of the number. Dip needle readings are shown in black. All are positive except those preceded by the negative sign. All readings show deviation of needles from the normal reading of the instrument used. Normal readings are omitted from the map except at each quarter section corner. All abnormal readings are shown.

Traverses were made on lines indicated—usually the N-S section and quarter lines. Dip needle readings were taken each 50 paces, dial compass readings each 10<sup>0</sup> paces when sun permitted.

Magnetic lines are indicated by heavy black lines, solid where definite and dashed where doubtful.

**CAUTION:** Almost any kind of rock may be the cause of magnetic attraction. Do not fail to read the following description of this township, and also chapter IV., in which the magnetic attractions are discussed.

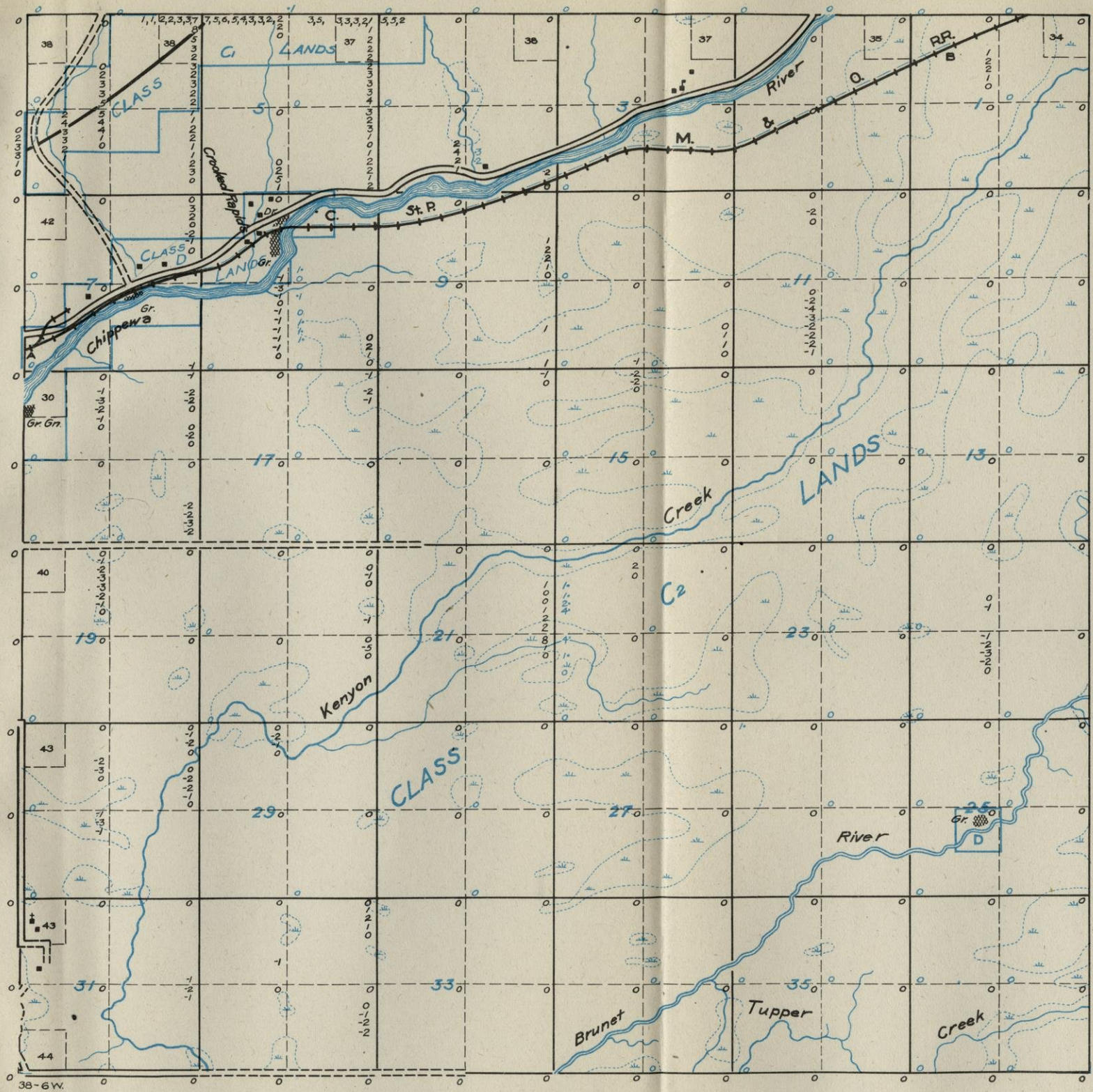

**PROFILE**  
VERTICAL SCALE: 1 space = 20'  
HORIZONTAL SCALE: same as map

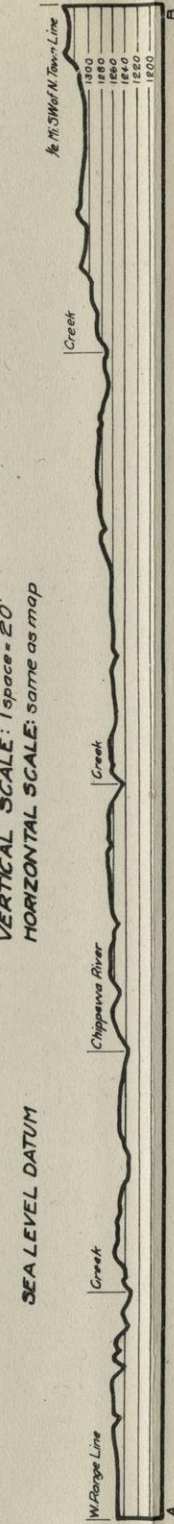

## TOWNSHIP 38 N., RANGE 7 W.

*Surface Features.*—Most of this township is flat and usually is not to exceed 60 feet above the river level. In the northeast corner there is somewhat rougher undulating topography rising to about 200 feet above the river. The general elevation of the northern part is higher than that of the remainder of the township. A rough hummocky moraine extends from the west into the southwest corner of section 31. The accompanying profiles show elevations varying from 1220 feet above sea level, where the Chippewa River crosses the section line between sections 13 and 14, to 1,405 feet at the quarter corner between 1 and 2.

The roads are in general not well graded or drained and are likely to be difficult of travel in wet weather. The main routes of travel are the roads leading from Radisson through sections 12, 35, and 36 to the township boundaries. Except in the northeast part of the township very little timber remains and the lumbering industry is giving way to farming. Liberal inducements are being offered to settlers and undoubtedly considerable areas of land will be cleared up for farming purposes in the near future. A large dam is under construction across the Chippewa River in section 23, where the erection of a pulp mill is contemplated.

*Glacial Drift.*—East of the Chippewa River and south of the middle of section 24 is a flat outwash plain nearly free from bowlders. North of the railway the township is dissected ground moraine with numerous small bowlders in some parts. The area west of the Chippewa River and south of the railroad is flat ground moraine somewhat lower in elevation than the northern part of the township. It is characterized by numerous large bowlders. The southwest corner of section 31 is hummocky terminal moraine rising to a height of about 75 feet above the ground moraine north of it.

The glacial deposits are largely sand and silt with little gravel in the outwash area; silt, gravel and some small bowlders in the dissected ground moraine; silt with much gravel and large and small bowlders in the flat ground moraine; and sand, silt and bowlders in the terminal moraine.

The thickness of drift in this township is not definitely known but will vary from nothing, in places along the Chippewa River, to probably as much as 200 feet in sections 1 and 2. The general level of the rock surface throughout the township probably does not vary greatly from that at the Chippewa River, in which case the depth

of surface seldom exceeds 75 feet. The deepest boring of which there is a record is a well 55 feet deep  $\frac{1}{4}$  mile west of the center of section 8. This did not reach the ledge.

*General Geology.*—All of the outcrops found in this township occur close to the Chippewa River and do not project appreciably above the surrounding country. Their locations are indicated on the township plat. All of the rocks exposed are hornblende biotite granites, usually coarse-grained and somewhat gneissic in texture. Feldspar crystals of 1 inch in length are common. The outcrop south of the river in section 13 is finer grained than the others and is cut by two dikes of coarser granite striking N. 38° W. and N. 5° E. The granite at the dam in section 23 is intruded by fine-grained hornblende granite gneiss, which at times develops a pegmatitic phase along the contact. Both of these rocks are intruded by a coarse pink granite, which contains a very notable percentage of magnetite and attracts the south end of the magnetic needle.

Since the area showing outcrops comprises but a very small part of the township, it is not possible to state definitely the character of the underlying formations of the remainder, but it seems quite probable that similar granites, with possibly some basic schists, underlie the southern two-thirds. From the results of the magnetic work it is thought probable that Huronian rocks underlie the northern third.

*Magnetic Observations.*—A general discussion of magnetic observations and their significance is given in Chapter IV. In this township abnormal readings of the dip needle and, in a few cases, of the dial were recorded but no well defined area or belt of attraction was found. The abnormal dip needle readings recorded were usually negative in character. Certain phases of the granite at the dam in section 23 produced the same effect on the needle and it is probable that rock of this kind is the cause of the negative readings found elsewhere in the township.

A suggestion of a connected line of positive attraction was found in sections 9 and 10 but it is not well defined. This may indicate the presence of Huronian rocks.

*Land Classification.*—For a thorough understanding of the principles of land classification employed in this work the reader is referred to chapter V. Lands in the immediate vicinity of granite outcrops are placed in class D, of no probable value as mineral lands. This includes the N. E.  $\frac{1}{4}$  of section 13, the E.  $\frac{1}{2}$  of section 22, all of



TOWN 38 N., R. 7 W.

Survey Made in July, 1914

Under the Direction of  
W. O. HOTCHKISS, State Geologist

AND  
E. F. BEAN and O. W. WHEELWRIGHT,  
in charge of Field Parties

BY  
W. C. BEAN, Chief of Party  
G. S. NISHIHARA, Asst. Geologist  
HOWARD QUINLAN, Asst. Geologist

**SYMBOLS AND ABBREVIATIONS.**  
The symbols and abbreviations used on this map are explained in Chapter II.

**TOWN AND RANGE LINES.**  
In constructing this map the south line of the township was laid off as a true east west line. The other boundary lines were then laid off with the lengths shown on the Land Survey plat. Some of the maps are therefore incorrect in shape but this is necessary because definite facts are lacking. The acreage of part of the lots in the north and west tier of sections is shown to give a check on the distances in these sections.

**LOCATIONS.**  
All locations are based on pacing traverses from government land corners. In many cases these were not found and it was necessary to continue the traverse several miles without a check. Locations of certain features may therefore be somewhat wrong. In such cases the feature sought may best be located by its relation to a stream, swamp, lake, or other feature shown on the map.

**PROFILES.**  
The locations of the profiles are shown on the map by dashed blue lines with black letters at the ends. Railroad profiles were furnished by the companies and show elevations of the ground rather than track in most cases; others are from road surveys by the State Highway Commission; most of them are hand level lines made by this Survey. Wherever possible the elevations above sea level are given. These elevations vary from 1050 to 1770 feet. A local datum plane was necessarily assumed in some cases. These cases are identifiable by the fact that the base line is always numbered 0.

**LAND CLASSIFICATION.**  
This is shown on the map by the blue letters. It is explained in the following township description and at length in chapter V.

**MAGNETIC DATA.**  
Dial compass readings are shown in blue figures. Eastward declinations are shown with a dot to the east and westward with a dot to west of the number. Dip needle readings are shown in black. All are positive except those preceded by the negative sign. All readings show deviation of needles from the normal reading of the instrument used. Normal readings are omitted from the map except at each quarter section corner. All abnormal readings are shown.

Traverses were made on lines indicated—usually the N-S section and quarter lines. Dip needle readings were taken each 50 paces, dial compass readings each 100 paces when sun permitted.

Magnetic lines are indicated by heavy black lines, solid where definite and dashed where doubtful.

**CAUTION:** Almost any kind of rock may be the cause of magnetic attraction. Do not fail to read the following description of this township, and also chapter IV., in which the magnetic attractions are discussed.

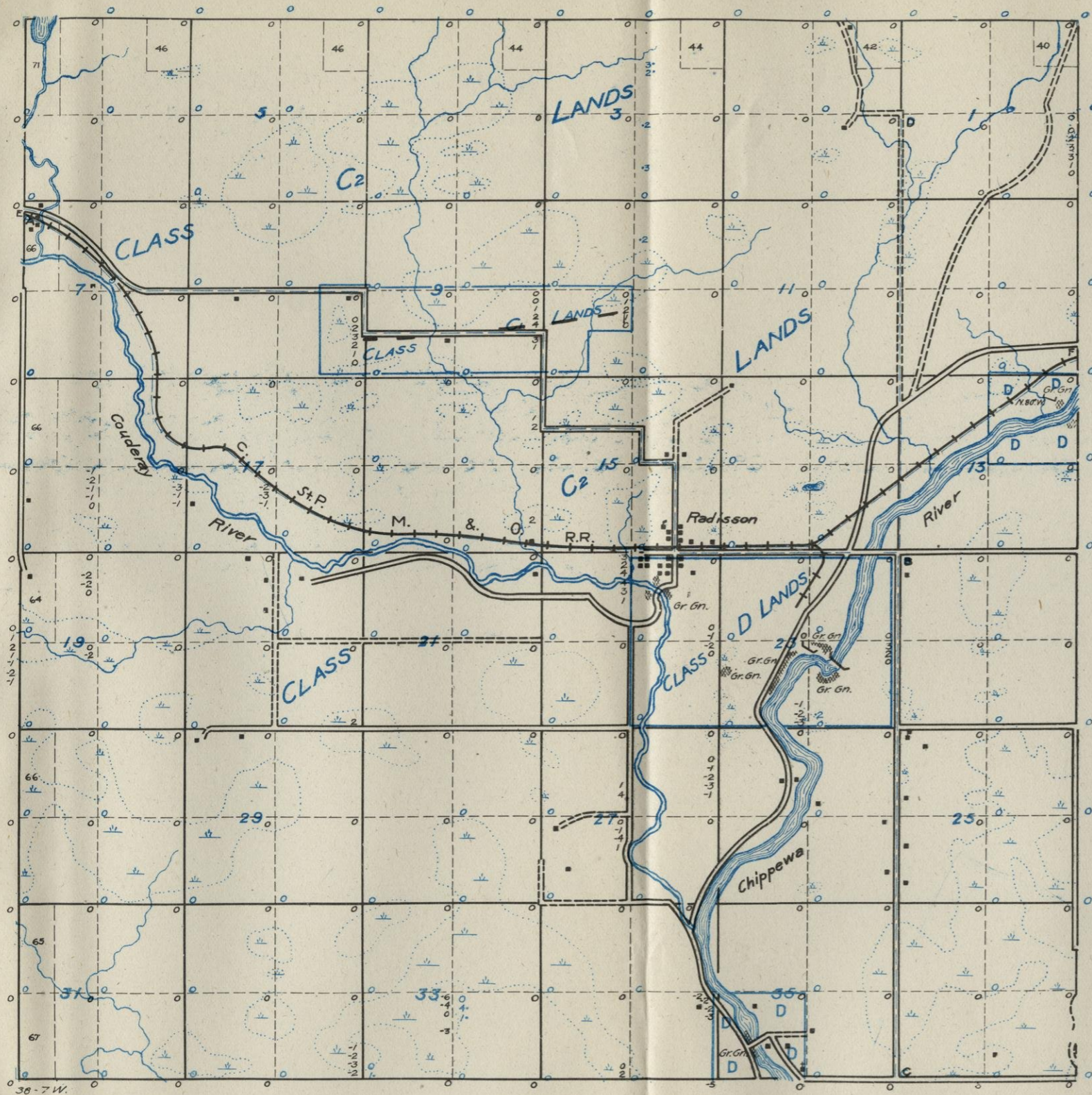

**PROFILE**  
VERTICAL SCALE: 1 space = 20'  
HORIZONTAL SCALE: same as map

**SEA LEVEL DATUM**

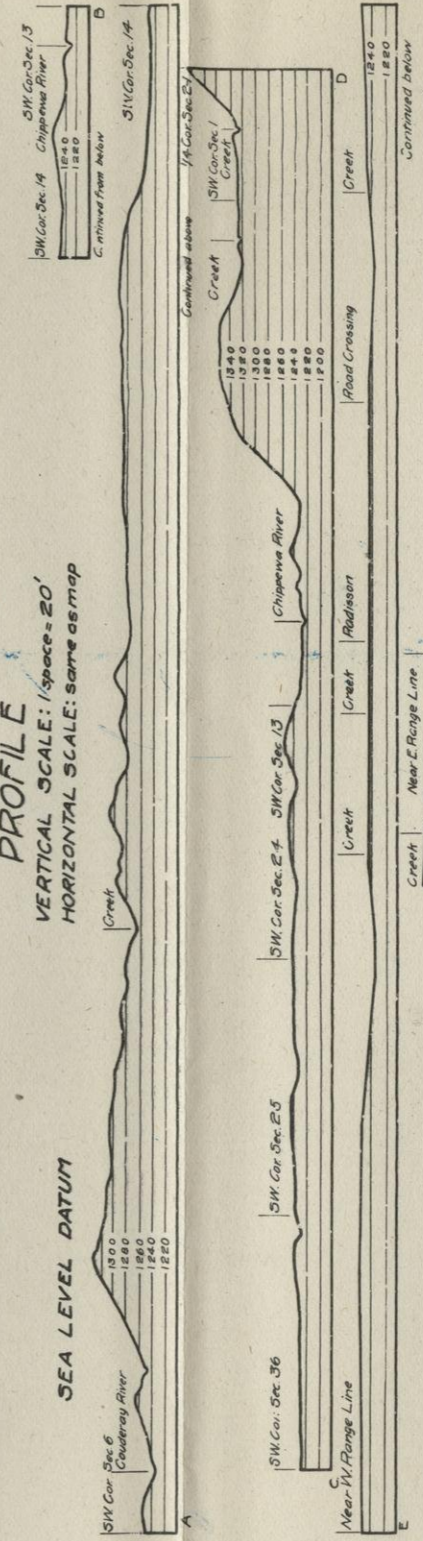

section 23, and the S. W. corner of section 35. Lands on the poorly defined magnetic line in sections 9 and 10 are classed as C1 although among the poorest lands of this class. All other lands are placed in class C2, since there is some doubt as to the character of the underlying rock. However, as stated above, it is believed that igneous rocks and metamorphic schists underlie most of the township and that there is very little chance for an iron formation.

*Exploration.*—In the light of present information exploration for iron ore does not seem warranted in this township.

## TOWNSHIP 38 N., RANGE 8 W.

*Surface Features.*—In the eastern part an area comprising most of sections 13, 14, 23, 24 and 25, is very flat and poorly drained, and is noticeably lower than the remainder of the township. Elsewhere the drainage is good and the surface has been considerably dissected by streams so that the topography is rather rough and in places the relief is pronounced. A prominent ridge extends along the east side of the Soo railroad from sections 35 and 36 to the Couderay River in sections 9 and 10, thence west to the township line in section 18. The topography here is very rough and is of the knob and basin type. The width of this belt varies from three-quarters of a mile to two miles. South and west of this is an area of considerable relief which rises from 200 to 275 feet above the eastern part of the township. The hills are broad with gentle slopes and the valleys are pronounced. This topography is the result of rock control.

The northern part of the township is very much dissected by the Couderay River and its tributaries so that it also presents considerable relief. The valley of the Couderay is usually from 60 to 80 feet below the general level of the surface. This depth is much greater in section 2. The width of the valley varies from  $\frac{1}{4}$  to  $\frac{1}{2}$  mile.

Profile A-B along the wagon road from the southwest corner of section 34 to the northeast corner of section 12 shows the marked elevation of the quartzite hills along the south border of the township, also the prominent ridge in sections 22, 15, and 11 and the descent to the valley of the Couderay. Since this road follows a selected route, the profile gives a poor idea of the type of topography in the ridge in sections 22, 15, and 11 and does not show the abruptness of the drop into the valley of the Couderay. Profile C-D is along the right of way of the Omaha railroad, but since this also follows a selected route the prominent features of the topography are not well brought out. It shows, however, a more abrupt drop to the valley of the Couderay and the pronounced difference in the elevations of the northeastern and southwestern parts of the township.

Most of the roads in this township are old tote roads which have been but little graded and as a consequence are in poor condition. Except during the dry seasons they are nearly impassable. Most of the timber has been removed but some scattered areas of hardwood still remain. Although there is much good farming land in this township there has been but little settlement up to the present time.

*Glacial Drift.*—The marked ridge above described presents very prominent terminal moraine characteristics. All the remainder of the township is covered by ground moraine deposits which are much dissected except in the flat area in the eastern part. Much of the topographic expression is due to rock control rather than to glacial deposition. The drift in the terminal moraine area is characteristically very sandy and rather lacking in boulders. Elsewhere the drift is more silty and boulders are of very common occurrence.

The occurrence of many outcrops in the western part of this township suggests shallow drift, but it is probable that it will prove to be deeper away from the quartzite areas.

*General Geology.*—A number of exposures of the Barron quartzite are found at points indicated on the map. In the southwest corner of section 19 is a pre-glacial gorge cut into quartzite and both sides are lined with angular blocks of this rock. Along the top of the gorge the quartzite is exposed at a number of places and shows a strike of N. 25° W. and a dip of 10° to the S. W. A number of forms suggesting fossils or mud flakes are found at this point. Along the railroad in the S. E.  $\frac{1}{4}$  of 19 and the N. W.  $\frac{1}{4}$  of 29 are two very small exposures which appear to strike about N. 30° W. and to dip to the S. W. at a very low angle. In the S. E.  $\frac{1}{4}$  of 21 the railroad has cut through the ledge to the depth of about 8 feet. The rock at this point has been minutely broken and is a mass of angular blocks seldom more than a foot through. The effects of local deformation are quite pronounced. The broken condition of the quartzite is shown in plate IV. The strike is about N. 20° W. and the dip averages about 15° to the S. W. The quartzite here appears to be intruded by small dikes of igneous rocks. About  $\frac{1}{4}$  mile N. E. along the wagon road is an outcrop of red decomposed granite gneiss which contains a considerable number of crystals of non-magnetic iron. This rock is similar to the red granite gneiss found beneath the quartzite in the townships to the south. West of Beverly is a pre-glacial gorge in this quartzite, now partially occupied by a small lake. The rock is exposed in the cliffs on both banks and for some distance to the west along the small stream which flows into this lake. It strikes nearly north and south and dips about 20° to the west. In the south half of section 8 there is another gorge cut into the quartzite. The rock strikes about N. 35° W. and dips 10° to the S. W. Two outcrops occur in the railway cuts in the north half of section 8 and the south half of section 5. The quartzite in the northernmost of these outcrops is very much lighter in color than is usual in this

Barron quartzite, but otherwise it does not differ from the other outcrops. The strike is N. 30° W. and dips 10°–12° S. W. The rock shows evidence of faulting on a very small scale.

*Magnetic Observations.*—No abnormal magnetic attraction of any consequence was found in this township.

*Land Classification.*—A general discussion of the principles of land classification employed in this work is given in Chapter V. The lands in this township in the immediate vicinity of the granite outcrop in section 22 are placed in class D. All other lands are placed in class C2. In making this classification the Barron quartzite is not taken into consideration, although there is a suggestion of rather unusual thickness in the vicinity of Beverly.

*Exploration.*—Exploration in this township can not be recommended with the information at hand. There is a possibility that iron formation may be present but there is no indication of it.

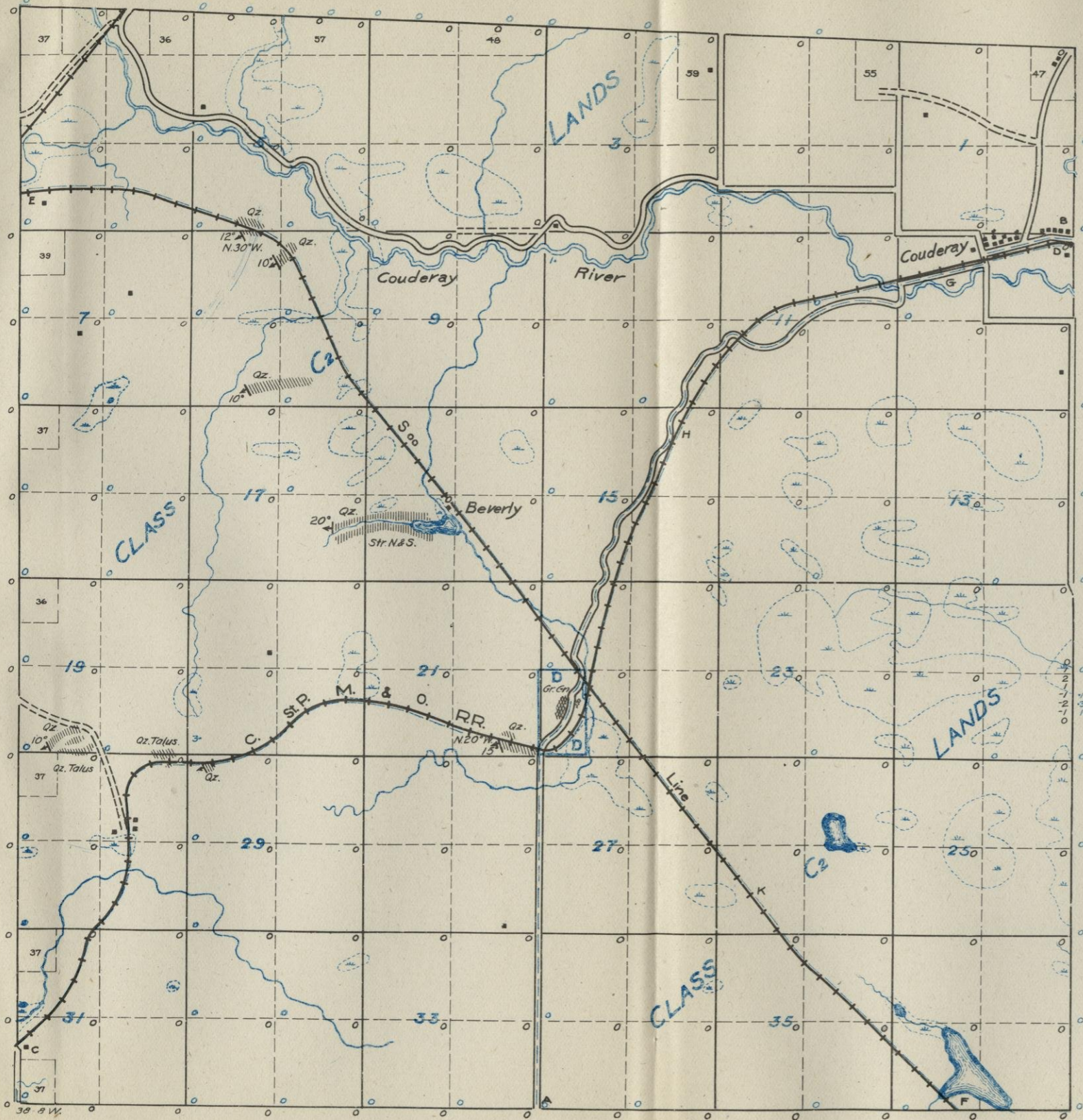

**PROFILES**  
 VERTICAL SCALE: 1 space = 20'  
 HORIZONTAL SCALE: same as map

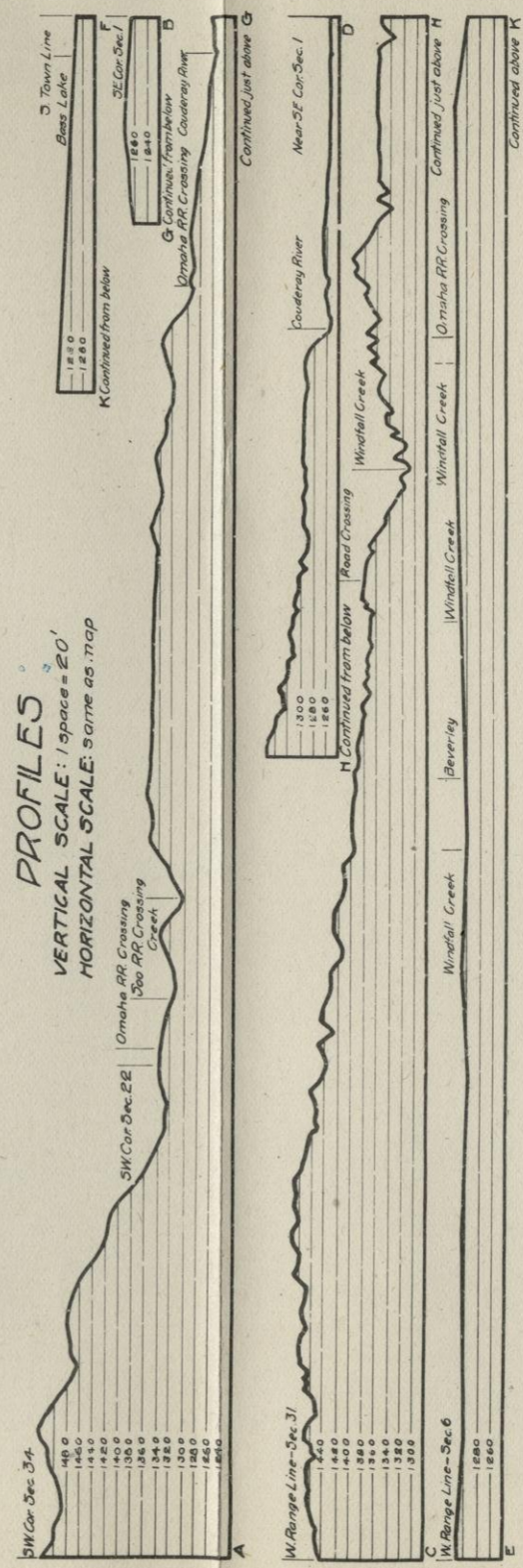

**TOWN 38 N., R. 8 W.**

Survey Made in August, 1914

Under the Direction of  
**W. O. HOTCHKISS**, State Geologist  
 AND  
**E. F. BEAN** and **O. W. WHEELWRIGHT**,  
 in charge of Field Parties  
 BY  
**W. C. BEAN**, Chief of Party  
**G. S. NISHIHARA**, Asst. Geologist  
**HOWARD QUINLAN**, Asst. Geologist

**SYMBOLS AND ABBREVIATIONS.**  
 The symbols and abbreviations used on this map are explained in Chapter II.

**TOWN AND RANGE LINES.**  
 In constructing this map the south line of the township was laid off as a true east west line. The other boundary lines were then laid off with the lengths shown on the Land Survey plat. Some of the maps are therefore incorrect in shape but this is necessary because definite facts are lacking. The acreage of part of the lots in the north and west tier of sections is shown to give a check on the distances in these sections.

**LOCATIONS.**  
 All locations are based on pacing traverses from government land corners. In many cases these were not found and it was necessary to continue the traverse several miles without a check. Locations of certain features may therefore be somewhat wrong. In such cases the feature sought may best be located by its relation to a stream, swamp, lake, or other feature shown on the map.

**PROFILES.**  
 The locations of the profiles are shown on the map by dashed blue lines with black letters at the ends. Railroad profiles were furnished by the companies and show elevations of the ground rather than track in most cases; others are from road surveys by the State Highway Commission; most of them are hand level lines made by this Survey. Wherever possible the elevations above sea level are given. These elevations vary from 1050 to 1770 feet. A local datum plane was necessarily assumed in some cases. These cases are identifiable by the fact that the base line is always numbered 0.

**LAND CLASSIFICATION.**  
 This is shown on the map by the blue letters. It is explained in the following township description and at length in chapter V.

**MAGNETIC DATA.**  
 Dial compass readings are shown in blue figures. Eastward declinations are shown with a dot to the east and westward with a dot to the west of the number. Dip needle readings are shown in black. All are positive except those preceded by the negative sign. All readings show deviation of needles from the normal reading of the instrument used. Normal readings are omitted from the map except at each quarter section corner. All abnormal readings are shown.

Traverses were made on lines indicated usually the N-S section and quarter lines. Dip needle readings were taken each 50 paces, dial compass readings each 100 paces when sun permitted.

Magnetic lines are indicated by heavy black lines, solid where definite and dashed where doubtful.

**CAUTION!** Almost any kind of rock may be the cause of magnetic attraction. Do not fail to read the following description of this township, and also chapter IV., in which the magnetic attractions are discussed.

## TOWNSHIP 38 N., RANGE 9 W.

*Surface Features.*—This township presents a great variety of interesting topographic features. In the south central part Lake Chetac occupies a very pronounced valley and through the center of section 2 and the east side of sections 11 and 14, is another prominent valley occupied by a small lake and stream. All evidence points to the fact that these two are parts of the same pre-glacial valley across which the glacier left a dam of heavy drift deposits in section 23. Evidence of a side valley is found at the east quarter post of section 26 where a depression not occupied by a stream at the present time, shows 60-foot rock walls.

East of this main valley the country is high and rather rugged. A very prominent hill trends north and south across the west half of section 13. Another prominent hill occupies the west half of section 1 and the east half of section 2. All that part of the township on the west side of the valley except sections 4, 5, 6, 7, and 8 has the rugged knob and basin type of topography. Relief is as great as 150 feet in places, and many small undrained lakes occupy the depressions between the hills. The five sections mentioned above have flat to very gently undulating surface.

The profiles shown on the map do not give an adequate idea of the topography because the railroads follow selected routes over the more level portions of the township. They give the elevation above sea level along the routes traversed.

There are no graded roads in this township but the sandy nature of the country makes the old winding tote roads passable at all times. Almost all of this township was originally covered with pine forests which have been entirely removed. A small amount of hardwood remains in section 36.

*Glacial Drift.*—The flat area in sections 4, 5, 6, 7, and 8 is outwash as is also a narrow strip around the north end of Lake Chetac and the valley in sections 2, 11, 12, and 14. The outwash deposits are sand, very coarse in places, and are nearly free from boulders. The hill in sections 1 and 2, the east side of section 12, and an area in the southeast corner including parts of sections 24, 25, 26, and 36 is ground moraine. The drift here consists of sand, silt, gravel and boulders. Except in a small part of section 36 it is, however, characteristically sandy. All of the remainder of the township is terminal moraine, usually of a very pronounced type. A narrow strip extends across section 13 to T. 38-8 W, where it continues for

many miles. The drift in the terminal moraine consists principally of sand and gravel with silt in places. Boulders are not present in great numbers.

In the northeastern and southeastern parts of the township the drift is not thick, as indicated by the fact that rocks are exposed in a few places. In the remainder of the township it is of considerable depth. On the north shore of Little Sissabagama Lake a well 160 feet deep did not reach ledge. Several drill holes were put down recently in search for ore but the depth of surface found is not known. It is believed that the thickness of the drift will exceed 200 feet in much of this terminal moraine area.

*General Geology.*—Outcrops of the Barron quartzite occur in sections 13, 26, and 36 at the locations shown on the map. In section 13 the branch line of the Soo railroad has cut into this rock and exposes it in a very small area near the northwest corner of the section. The road apparently runs on top of the ledge for some distance south of the exposure. The rock here is a finely banded pink and white quartzite composed of fine sand grains rather poorly cemented. The strike is about northwest and the dip not over  $5^{\circ}$  to the southwest. In section 26 a pre-glacial gorge through the quartzite has been largely covered with glacial drift, but there is exposed a face of 30 feet of quartzite and for some distance along the sides of the gorge heavy talus slopes are found. The rock at this point is pink, varying to the banded pink and white variety like that in section 13. The strike is nearly north and south and the dip about  $10^{\circ}$  to the west. In section 36 are a few small exposures of quartzite along the creek flowing southwest from Yarnell. The rock is rather darker red than that found in the outcrops to the north but otherwise is the same. The strike is nearly north and south and the dip about  $15^{\circ}$  to the west.

The extent to which this quartzite formation underlies the township is rather uncertain but there is little doubt that all that part east of Lake Chetac and the branch railroad is underlain by it. It is also quite certain that the large hill in sections 1 and 2 is a result of the presence of quartzite. The existence of this rock west of the large valley above described is not definitely known but there is good reason to believe that it is present in the north central part. An idea of the distribution can best be obtained from plate I.

Several drill holes have been recently put down in the township but the character of the rock encountered is not known. The locations of these drill holes are: three in section 18, drilled to depths



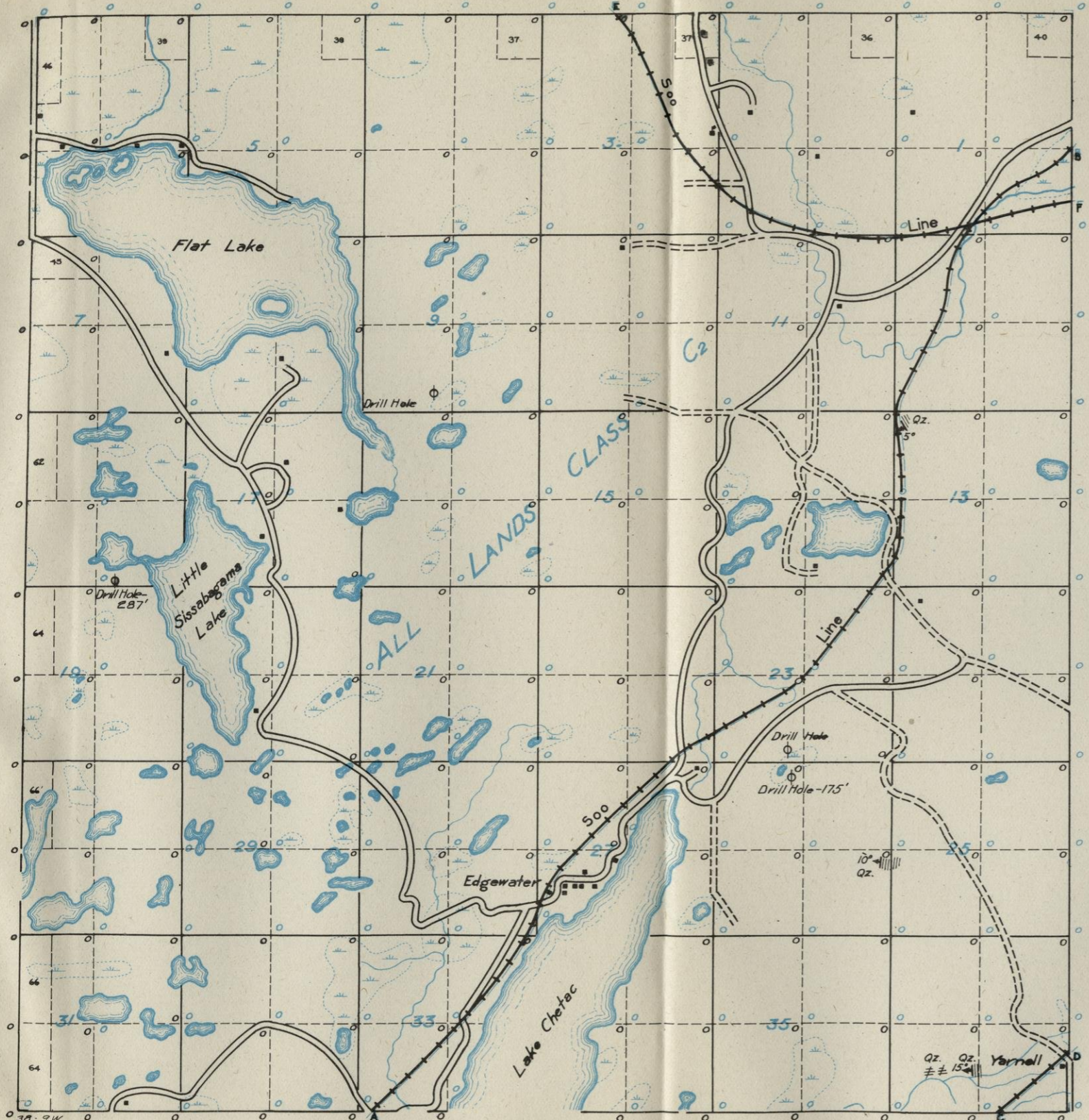

**PROFILES**  
 VERTICAL SCALE: 1 space = 20'  
 HORIZONTAL SCALE: same as map

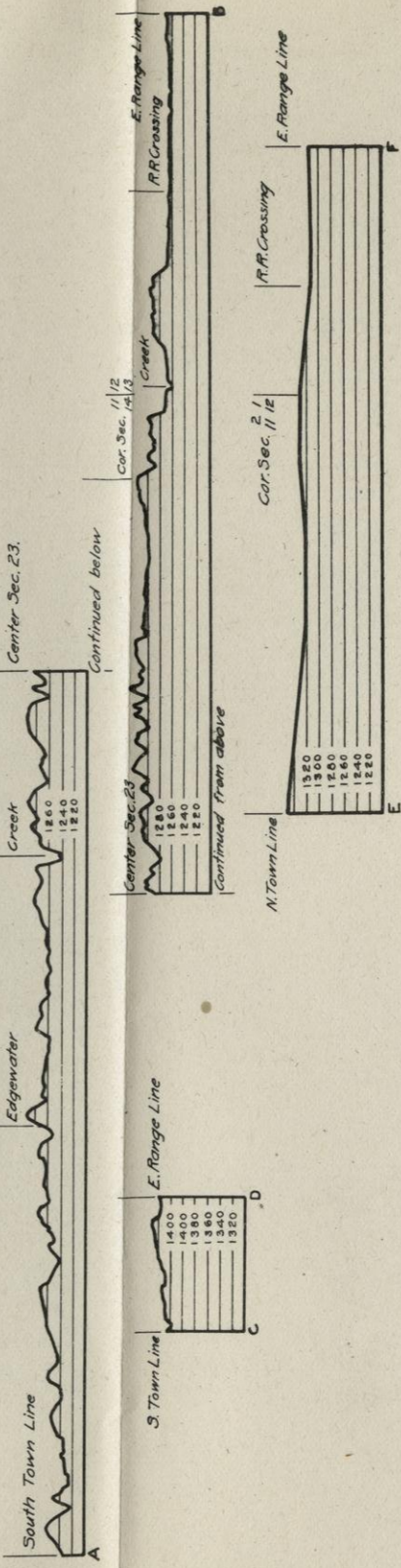

**TOWN 38 N., R. 9W.**

Survey Made in July, 1914

Under the Direction of  
**W. O. HOTCHKISS, State Geologist**  
 AND  
**E. F. BEAN and O. W. WHEELWRIGHT,**  
 in charge of Field Parties

BY  
 R. W. CLARK, Chief of Party  
 J. R. ROBERTS, Asst. Geologist  
 W. G. CRAWFORD, Asst. Geologist

**SYMBOLS AND ABBREVIATIONS.**  
 The symbols and abbreviations used on this map are explained in Chapter II.

**TOWN AND RANGE LINES.**  
 In constructing this map the south line of the township was laid off as a true east west line. The other boundary lines were then laid off with the lengths shown on the Land Survey plat. Some of the maps are therefore incorrect in shape but this is necessary because definite facts are lacking. The acreage of part of the lots in the north and west tier of sections is shown to give a check on the distances in these sections.

**LOCATIONS.**  
 All locations are based on pacing traverses from government land corners. In many cases these were not found and it was necessary to continue the traverse several miles without a check. Locations of certain features may therefore be somewhat wrong. In such cases the feature sought may best be located by its relation to a stream, swamp, lake, or other feature shown on the map.

**PROFILES.**  
 The locations of the profiles are shown on the map by dashed blue lines with black letters at the ends. Railroad profiles were furnished by the companies and show elevations of the ground rather than track in most cases; others are from road surveys by the State Highway Commission; most of them are hand level lines made by this Survey. Wherever possible the elevations above sea level are given. These elevations vary from 1050 to 1770 feet. A local datum plane was necessarily assumed in some cases. These cases are identifiable by the fact that the base line is always numbered 0.

**LAND CLASSIFICATION.**  
 This is shown on the map by the blue letters. It is explained in the following township description and at length in chapter V.

**MAGNETIC DATA.**  
 Dial compass readings are shown in blue figures. Eastward declinations are shown with a dot to the east and westward with a dot to west of the number. Dip needle readings are shown in black. All are positive except those preceded by the negative sign. All readings show deviation of needles from the normal reading of the instrument used. Normal readings are omitted from the map except at each quarter section corner. All abnormal readings are shown.

Traverses were made on lines indicated—usually the N-S section and quarter lines. Dip needle readings were taken each 50 paces, dial compass readings each 100 paces when sun permitted.

Magnetic lines are indicated by heavy black lines, solid where definite and dashed where doubtful.

**CAUTION:** Almost any kind of rock may be the cause of magnetic attraction. Do not fail to read the following description of this township, and also chapter IV., in which the magnetic attractions are discussed.

as follows: 80 feet, 117 feet, and 287 feet; one in the S. E. corner of the S. W.  $\frac{1}{4}$  of section 9, now flowing well; near the N.  $\frac{1}{4}$  S. of 26, said to have been drilled to a depth of 175 feet; in the S. E.  $\frac{1}{4}$  of the S. W.  $\frac{1}{4}$  of 23, depth not known. The fact that a flowing well was found in section 9 indicates that either a poorly consolidated quartzite or a sandstone was cut by the drill.

Sandstone probably occurs over most of that part of the township where the quartzite is absent. Nothing is known of the character of the older rocks beneath.

*Land Classification.*—All lands in this township are placed in class C2, since the possibility of the existence of an iron formation is recognized, but there is nothing to indicate its presence.

*Exploration.*—In the light of present information exploration in this township does not appear to be warranted.

## TOWNSHIP 38 N., RANGE 10 W.

*Surface Features.*—The greater part of this township is characterized by very rugged topography of the knob and basin type. Numerous small depressions filled with undrained lakes are found in nearly every section. Local relief of 100 feet or more is not uncommon. Two less rugged areas occur, one in sections 1 and 12, and the other in sections 5, 6, 7, 8, 17, 18, and 19. Here the relief is somewhat less, the knobs and sags much less prominent though not lacking entirely. A series of long narrow lakes connected by a stream may mark the location of a pre-glacial valley across the township from northeast to southwest.

There are a number of roads in this township, but all are old tote roads or logging roads and were it not for the fact that they traverse sandy, gravelly country they would be practically impassable at all times. As it is, most of them are passable with difficulty even during the dry seasons. A few scattered areas of hardwood timber still remain but most of the township has been logged. The largest area of timber is found in sections 27, 33, and 34. There are but few settlers in the township, and most of them are along the larger lakes in the western part.

*Glacial Drift.*—Nearly all the township is covered with heavy terminal moraine which presents all the characteristics of this type of glacial deposits with the one exception that boulders are not common. The more level areas above mentioned are covered with ground moraine, although they have some of the characteristics of terminal moraines. Small areas of outwash occur in the southeast quarter of section 29 and in the northwest part of 31. All of the drift is characteristically sandy and gravelly, but some of the more level areas have a good coating of silt. A remarkable deposit of stratified clay occurs in the eastern part of section 24 around the  $\frac{1}{4}$  S. It is located on a very high hill, probably 150 feet above the small lake one quarter mile south of the corner and because of its elevation has been deeply eroded by intermittent streams. The clay is of very uniform composition and apparently entirely free from pebbles. It has been deposited in very regular layers from  $\frac{1}{2}$  to 1 inch thick. The thickness is not known but is probably at least 40 feet. The horizontal extent was not measured but it undoubtedly covers many acres. No tests were made to determine the value of this clay for manufacturing purposes. The evidence indicates that this deposit was made in a glacial lake retained on the

## TOWN 38 N., R. 10W.

Survey Made in August, 1914

Under the Direction of

W. O. HOTCHKISS, State Geologist

AND

E. F. BEAN and O. W. WHEELWRIGHT,  
in charge of Field Parties

BY

R. W. CLARK, Chief of Party

J. R. ROBERTS, Asst. Geologist

W. G. CRAWFORD, Asst. Geologist

### SYMBOLS AND ABBREVIATIONS.

The symbols and abbreviations used on this map are explained in Chapter II.

### TOWN AND RANGE LINES.

In constructing this map the south line of the township was laid off as a true east west line. The other boundary lines were then laid off with the lengths shown on the Land Survey plat. Some of the maps are therefore incorrect in shape but this is necessary because definite facts are lacking. The acreage of part of the lots in the north and west tier of sections is shown to give a check on the distances in these sections.

### LOCATIONS.

All locations are based on pacing traverses from government land corners. In many cases these were not found and it was necessary to continue the traverse several miles without a check. Locations of certain features may therefore be somewhat wrong. In such cases the feature sought may best be located by its relation to a stream, swamp, lake, or other feature shown on the map.

### PROFILES.

The locations of the profiles are shown on the map by dashed blue lines with black letters at the ends. Railroad profiles were furnished by the companies and show elevations of the ground rather than track in most cases; others are from road surveys by the State Highway Commission; most of them are hand level lines made by this Survey. Wherever possible the elevations above sea level are given. These elevations vary from 1050 to 1770 feet. A local datum plane was necessarily assumed in some cases. These cases are identifiable by the fact that the base line is always numbered 0.

### LAND CLASSIFICATION.

This is shown on the map by the blue letters. It is explained in the following township description and at length in chapter V.

### MAGNETIC DATA.

Dial compass readings are shown in blue figures. Eastward declinations are shown with a dot to the east and westward with a dot to west of the number. Dip needle readings are shown in black. All are positive except those preceded by the negative sign. All readings show deviation of needles from the normal reading of the instrument used. Normal readings are omitted from the map except at each quarter section corner. All abnormal readings are shown.

Traverses were made on lines indicated—usually the N-S section and quarter lines. Dip needle readings were taken each 50 paces, dial compass readings each 100 paces when sun permitted.

Magnetic lines are indicated by heavy black lines, solid where definite and dashed where doubtful.

**CAUTION:** Almost any kind of rock may be the cause of magnetic attraction. Do not fail to read the following description of this township, and also chapter IV., in which the magnetic attractions are discussed.

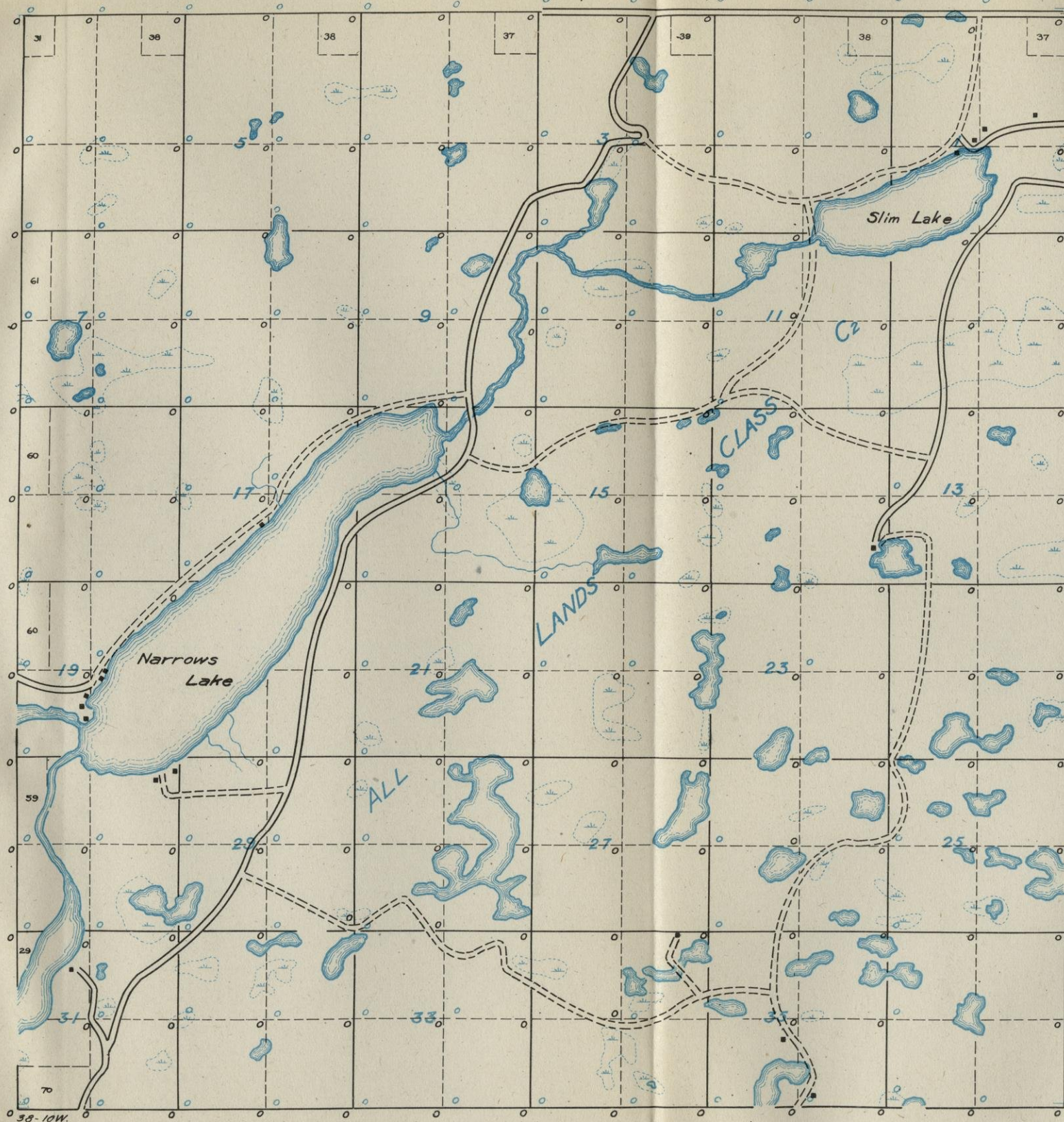

south side by a morainal ridge and on the north side by the glacier itself.

There are no wells in the township and since no outcrops occur it is impossible to state the depth of the drift, but it is estimated to exceed 100 feet in all parts of the township.

*General Geology.*—There are no exposures of rock nor indications of the character of the underlying formations. From information obtained in this general area it seems probable that this township is underlain by sandstone.

*Magnetic Observations.*—No abnormal magnetic attraction was found.

*Land Classifications.*—The principles of land classification employed in this work are discussed in Chapter V. Owing to the lack of information all lands are placed in class C2.

*Exploration.*—There is no information upon which to base recommendations for exploration in this township.

## TOWNSHIP 38 N., RANGE 11 W.

*Surface Features.*—The eastern tier of sections and the northern half of the township is gently to roughly undulating, with numerous lakes and swamps. There is an area of rough undulating topography in the southwestern part. The remainder of the township is level to gently undulating. Long Lake which occupies a drift blocked valley crosses the southeastern part of the township. The accompanying profile E-C shows that the northwest corner of section 3 is about 100 feet lower than the south central part of the township. Profile A-B shows a cross section of the valley which connects Bass and Devils Lake. This is probably a pre-glacial valley.

The main traveled roads are good. Except in the area southwest of Devils Lake, most of the timber has been cut. There are a number of excellent farms in the township.

*Glacial Drift.*—The extreme eastern part and a large portion of the northern half of the township, and parts of sections 31, 32, and 33 are terminal moraine. There is one area of outwash in sections 21, 22, 27, and 28 and another in section 36. The remainder of the township is ground moraine, gently undulating for the most part, but stream dissected in the area north of Yellow River.

The glacial deposits are much sand, silt and a few bowlders in the terminal moraine; much sand, some silt and bowlders in the ground moraine; much sand and some silt in the outwash.

But two cases are known where ledge was reached in wells, one in section 3, where sandstone was found at a depth of 140 feet; the other in section 8, reached ledge at a depth of 108 feet. Wells in sections 21 and 22 show depths of 84 to 120 feet without reaching ledge. The numerous angular quartzite bowlders west of Devils Lake in section 33 seem to indicate that the drift covering there is thin. Well records seem to indicate that over the larger part of the township the drift covering averages 100 feet in thickness.

*General Geology.*—There are no rock exposures in this township. Near Devils Lake in the southwest corner of section 33 are a number of angular blocks of quartzite on the side of a hill, which suggest that possibly part of this area may be underlain by the Barron formation. However, this is not certain. Sandstone was reported from a well in the S. E.  $\frac{1}{4}$  of section 3 and in section 8, and it is probable that the entire township outside of the possible quartzite in section 33 is underlain by this rock.

TOWN 38 N., R. 11 W.

Survey Made in August, 1914

Under the Direction of

W. O. HOTCHKISS, State Geologist

AND

E. F. BEAN and O. W. WHEELWRIGHT,  
in charge of Field Parties

BY

W. A. DOBIE, Chief of Party

O. W. POTTER, Asst. Geologist

D. G. THOMPSON, Asst. Geologist

**SYMBOLS AND ABBREVIATIONS.**  
The symbols and abbreviations used on this map are explained in Chapter II.

**TOWN AND RANGE LINES.**

In constructing this map the south line of the township was laid off as a true east west line. The other boundary lines were then laid off with the lengths shown on the Land Survey plat. Some of the maps are therefore incorrect in shape but this is necessary because definite facts are lacking. The acreage of part of the lots in the north and west tier of sections is shown to give a check on the distances in these sections.

**LOCATIONS.**

All locations are based on pacing traverses from government land corners. In many cases these were not found and it was necessary to continue the traverse several miles without a check. Locations of certain features may therefore be somewhat wrong. In such cases the feature sought may best be located by its relation to a stream, swamp, lake, or other feature shown on the map.

**PROFILES.**

The locations of the profiles are shown on the map by dashed blue lines with black letters at the ends. Railroad profiles were furnished by the companies and show elevations of the ground rather than track in most cases; others are from road surveys by the State Highway Commission: most of them are hand level lines made by this Survey. Wherever possible the elevations above sea level are given. These elevations vary from 1050 to 1770 feet. A local datum plane was necessarily assumed in some cases. These cases are identifiable by the fact that the base line is always numbered 0.

**LAND CLASSIFICATION.**

This is shown on the map by the blue letters. It is explained in the following township description and at length in chapter V.

**MAGNETIC DATA.**

Dial compass readings are shown in blue figures. Eastward declinations are shown with a dot to the east and westward with a dot to west of the number. Dip needle readings are shown in black. All are positive except those preceded by the negative sign. All readings show deviation of needles from the normal reading of the instrument used. Normal readings are omitted from the map except at each quarter section corner. All abnormal readings are shown.

Traverses were made on lines indicated—usually the N-S section and quarter lines. Dip needle readings were taken each 50 paces, dial compass readings each 100 paces when sun permitted.

Magnetic lines are indicated by heavy black lines, solid where definite and dashed where doubtful.

**CAUTION:** Almost any kind of rock may be the cause of magnetic attraction. Do not fail to read the following description of this township, and also chapter IV., in which the magnetic attractions are discussed.

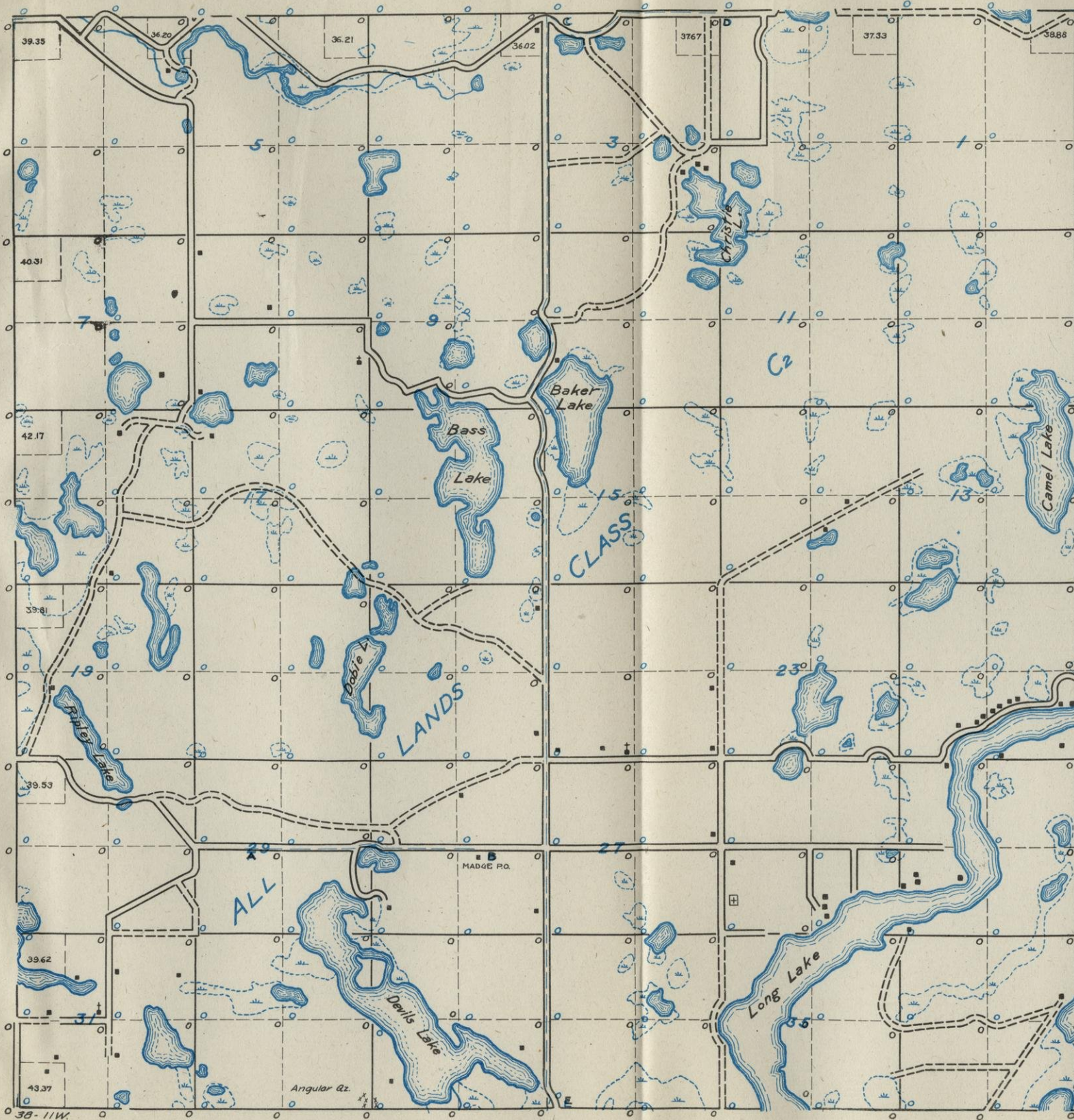

**PROFILE**

VERTICAL SCALE: 1 space = 20'  
HORIZONTAL SCALE: same as map

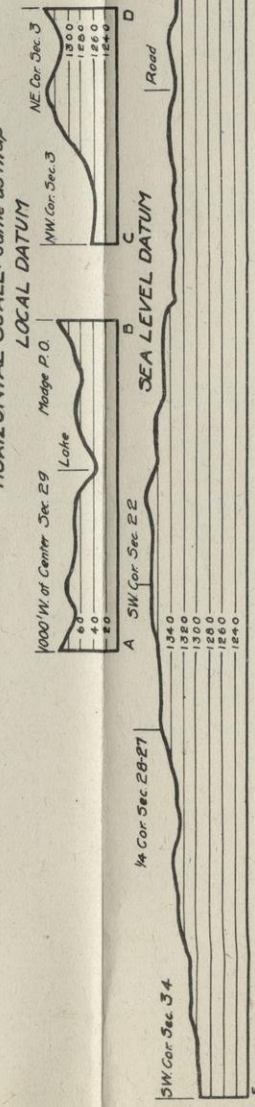

*Magnetic Observations.*—No abnormal attraction was found in this township.

*Land Classification.*—The principles of land classification employed in this work are discussed in Chapter V. All lands in this township are placed in class C2, for the reason that there is no definite information as to the character of the rock beneath the sandstone.

*Exploration.*—Exploration in this township is not recommended.



## TOWNSHIP 39 N., RANGE 6 E.

*Surface Features.*—The work done in this township consists of half mile traverses in the south one-third and a traverse along the road in sections 14 and 23 to Lake Minocqua. The topography consists of alternate belts of rough surface and flat country. The north half of section 27, nearly all of section 26, all of sections 25 and 36, and the east half of section 35 have a very rugged pitted surface with several undrained lakes occupying depressions. West of this is a plain extending to Rush Lake and into the east side of section 33. Then follows a rough area extending well into sections 30 and 31, which is bordered on the west by another plain. The rougher sections are characterized by numerous knobs and basins and have a relief of about 75 feet.

The roads are not on property lines but fit their locations to the topography. They are good because of the fact that the country is sandy. Most of the timber has been removed but some jack pine remains in sections 28, 30, 31, 32 and 33.

*Glacial Drift.*—The rougher belts above described are terminal moraines usually of a very pronounced type. The drift consists of sand and gravel and some bowlders. The flat areas are outwash and are composed almost entirely of sand.

There is no information bearing on the depth of the drift but it is believed to exceed 100 feet in all that part of the township surveyed.

*General Geology.*—No exposures of rock were found in that part of the township surveyed but from general considerations and evidence obtained from the magnetic work it is believed that the underlying rocks are Huronian in age although possibly largely greenstones.

*Magnetic Observations.*—A general discussion of magnetic observations and their significance is given in Chapter IV. That part of the township surveyed is characterized by areas of mild attractions which do not form distinct lines. Their irregularity makes it appear that they do not result from the presence of an iron formation. More probably the cause is greenstone.

*Land Classification.*—A general discussion of the principles of land classification employed in this work is given in Chapter V. All lands in this township are classed as C2, since there is a possibility that iron formation may be present.

TOWN 39 N., R. 6E.

Survey Made in October, 1913

Under the Direction of  
W. O. HOTCHKISS, State Geologist  
AND  
E. F. BEAN and O. W. WHEELWRIGHT,  
in charge of Field Parties  
BY

E. F. BEAN, Chief of Party

J. O. BRYANT, Asst. Geologist

**SYMBOLS AND ABBREVIATIONS.**  
The symbols and abbreviations used on this map are explained in Chapter II.

**TOWN AND RANGE LINES.**  
In constructing this map the south line of the township was laid off as a true east west line. The other boundary lines were then laid off with the lengths shown on the Land Survey plat. Some of the maps are therefore incorrect in shape but this is necessary because definite facts are lacking. The acreage of part of the lots in the north and west tier of sections is shown to give a check on the distances in these sections.

**LOCATIONS.**  
All locations are based on pacing traverses from government land corners. In many cases these were not found and it was necessary to continue the traverse several miles without a check. Locations of certain features may therefore be somewhat wrong. In such cases the feature sought may best be located by its relation to a stream, swamp, lake, or other feature shown on the map.

**PROFILES.**  
The locations of the profiles are shown on the map by dashed blue lines with black letters at the ends. Railroad profiles were furnished by the companies and show elevations of the ground rather than track in most cases; others are from road surveys by the State Highway Commission; most of them are hand level lines made by this Survey. Wherever possible the elevations above sea level are given. These elevations vary from 1050 to 1770 feet. A local datum plane was necessarily assumed in some cases. These cases are identifiable by the fact that the base line is always numbered 0.

**LAND CLASSIFICATION.**  
This is shown on the map by the blue letters. It is explained in the following township description and at length in chapter V.

**MAGNETIC DATA.**  
Dial compass readings are shown in blue figures. Eastward declinations are shown with a dot to the east and westward with a dot to west of the number. Dip needle readings are shown in black. All are positive except those preceded by the negative sign. All readings show deviation of needles from the normal reading of the instrument used. Normal readings are omitted from the map except at each quarter section corner. All abnormal readings are shown.

Traverses were made on lines indicated—usually the N-S section and quarter lines. Dip needle readings were taken each 50 paces, dial compass readings each 100 paces when sun permitted.

Magnetic lines are indicated by heavy black lines, solid where definite and dashed where doubtful.

**CAUTION:** Almost any kind of rock may be the cause of magnetic attraction. Do not fail to read the following description of this township, and also chapter IV., in which the magnetic attractions are discussed.

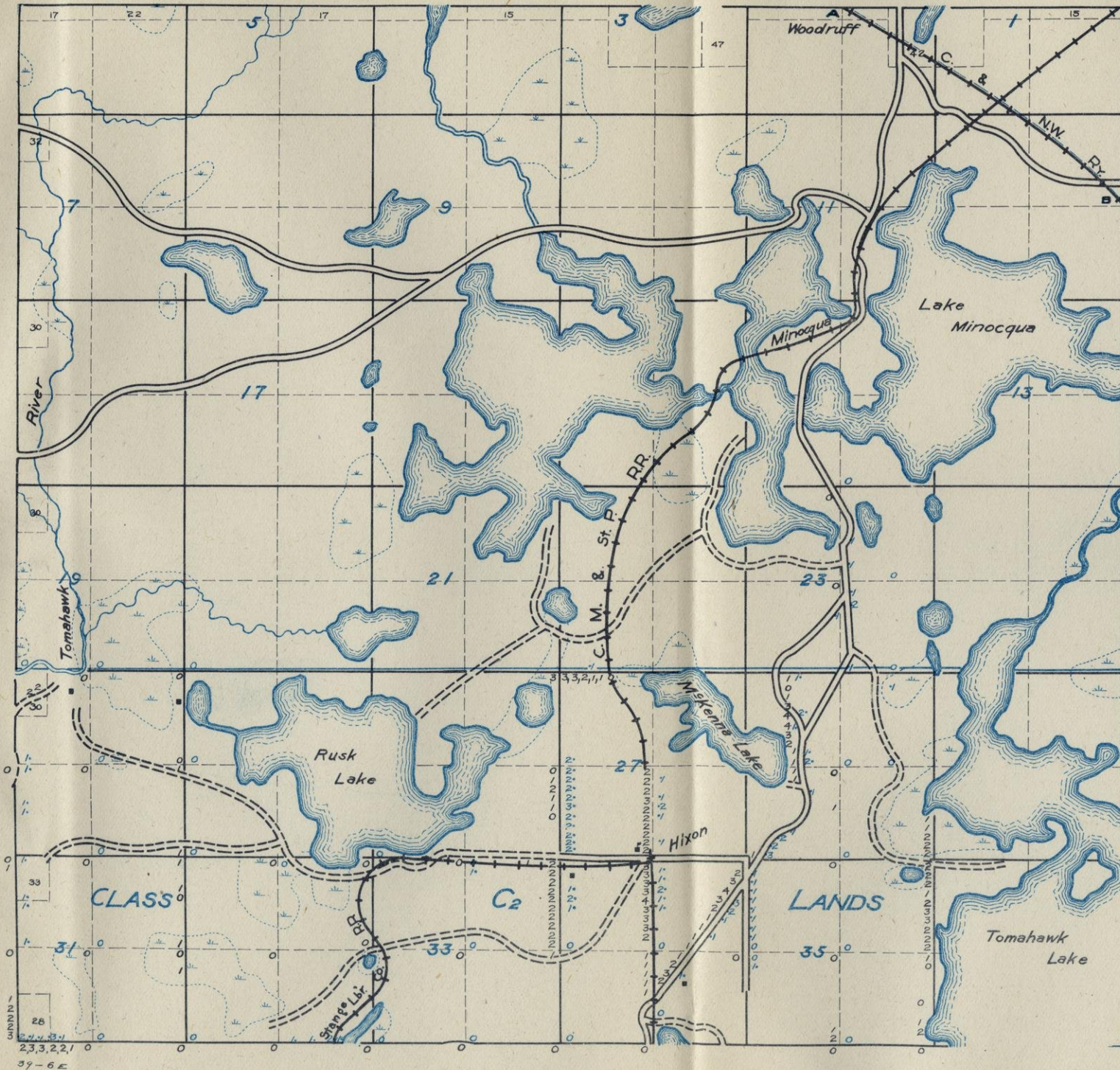

**PROFILE**

VERTICAL SCALE: 1 space = 20'

HORIZONTAL SCALE: same as map

SEA LEVEL DATUM

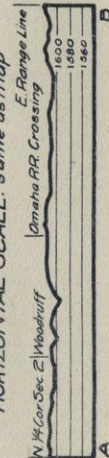

*Exploration.*—No information was obtained on which the exploration of any particular lands can be strongly recommended. If exploration is to be undertaken the best places are the areas of mild attraction in sections 26, 27, 28, 33, 34, 35 and 36. Much of the work done in exploration for iron ore is wasted because of failure to make intelligent use of the geologic and magnetic data to be obtained by a careful preliminary survey, and because the geologic information given by the drill is not properly used as a guide for further work. The value of careful scientific methods of exploration therefore cannot be too strongly emphasized. If exploration is contemplated in this township the discussion of this subject in Chapter VI should be carefully studied.

## TOWNSHIP 39 N., RANGE 3 E.

*Surface Features.*—Only the south third of the township was surveyed. The area covered is nearly level except in the southwest corner of section 34 where differences in elevation of 50 feet are found. There are a number of rock exposures but none of them have any topographic expression.

There are no roads and no settlers in the part of the township surveyed, but a good road to Fifield has been built along the north line of the township. Considerable hardwood and hemlock remain uncut in sections 25, 26, 27, 28, 33, 34, 35 and 36, but the remainder of the south third is cut over.

*Glacial Drift.*—There is a small area of terminal moraine in the southwest part of section 34, but the remainder is ground moraine. The drift in the terminal moraine is sand, gravel and boulders. In the ground moraine there is in addition a considerable quantity of silt. The west half is, however, characteristically more sandy than the eastern part of the township. Boulders, many of which are of large size, are very numerous. Numerous outcrops on nearly every section indicate that the drift covering is very shallow.

*General Geology.*—In the area surveyed many outcrops of granite were found, as indicated on the map. The rock is usually a medium grained pink granite composed of feldspar, quartz, and some biotite. Intrusions of coarse pegmatite are found. A large amount of biotite is found in an outcrop near the north quarter post of section 29.

While nearly all of the outcrops show some gneissic structure, as a rule, it is poorly developed and the granite has a fresh, unaltered appearance. This suggests that the granite may be intruded into the Huronian rocks but as no contacts were found, it is impossible to definitely determine this. While no work was done in the northern two-thirds of the township, it is believed that the granite will be found to underlie all of that part south of a line connecting the south side of Pike and Riley lakes. North of this, more basic rocks, such as greenstones and hornblende schists, are thought to be the underlying formations. These conclusions are based largely on the results of work in the township to the west.

*Magnetic Observations.*—A general discussion of magnetic observations and their significance is given in Chapter IV. Some very mild irregular positive and negative abnormal dip needle readings

## TOWN 39 N., R. 3E.

Survey Made in September, 1913

Under the Direction of

W. O. HOTCHKISS, State Geologist

AND

E. F. BEAN and O. W. WHEELWRIGHT,  
in charge of Field Parties

BY

J. C. SCOLES, Chief of Party

E. T. HODGE, Asst. Geologist

### SYMBOLS AND ABBREVIATIONS.

The symbols and abbreviations used on this map are explained in Chapter II.

### TOWN AND RANGE LINES.

In constructing this map the south line of the township was laid off as a true east west line. The other boundary lines were then laid off with the lengths shown on the Land Survey plat. Some of the maps are therefore incorrect in shape but this is necessary because definite facts are lacking. The acreage of part of the lots in the north and west tier of sections is shown to give a check on the distances in these sections.

### LOCATIONS.

All locations are based on pacing traverses from government land corners. In many cases these were not found and it was necessary to continue the traverse several miles without a check. Locations of certain features may therefore be somewhat wrong. In such cases the feature sought may best be located by its relation to a stream, swamp, lake, or other feature shown on the map.

### PROFILES.

The locations of the profiles are shown on the map by dashed blue lines with black letters at the ends. Railroad profiles were furnished by the companies and show elevations of the ground rather than track in most cases; others are from road surveys by the State Highway Commission; most of them are hand level lines made by this Survey. Wherever possible the elevations above sea level are given. These elevations vary from 1050 to 1770 feet. A local datum plane was necessarily assumed in some cases. These cases are identifiable by the fact that the base line is always numbered 0.

### LAND CLASSIFICATION.

This is shown on the map by the blue letters. It is explained in the following township description and at length in chapter V.

### MAGNETIC DATA.

Dial compass readings are shown in blue figures. Eastward declinations are shown with a dot to the east and westward with a dot to west of the number. Dip needle readings are shown in black. All are positive except those preceded by the negative sign. All readings show deviation of needles from the normal reading of the instrument used. Normal readings are omitted from the map except at each quarter section corner. All abnormal readings are shown.

Traverses were made on lines indicated—usually the N-S section and quarter lines. Dip needle readings were taken each 50 paces, dial compass readings each 100 paces when sun permitted.

Magnetic lines are indicated by heavy black lines, solid where definite and dashed where doubtful.

**CAUTION:** Almost any kind of rock may be the cause of magnetic attraction. Do not fail to read the following description of this township, and also chapter IV., in which the magnetic attractions are discussed.

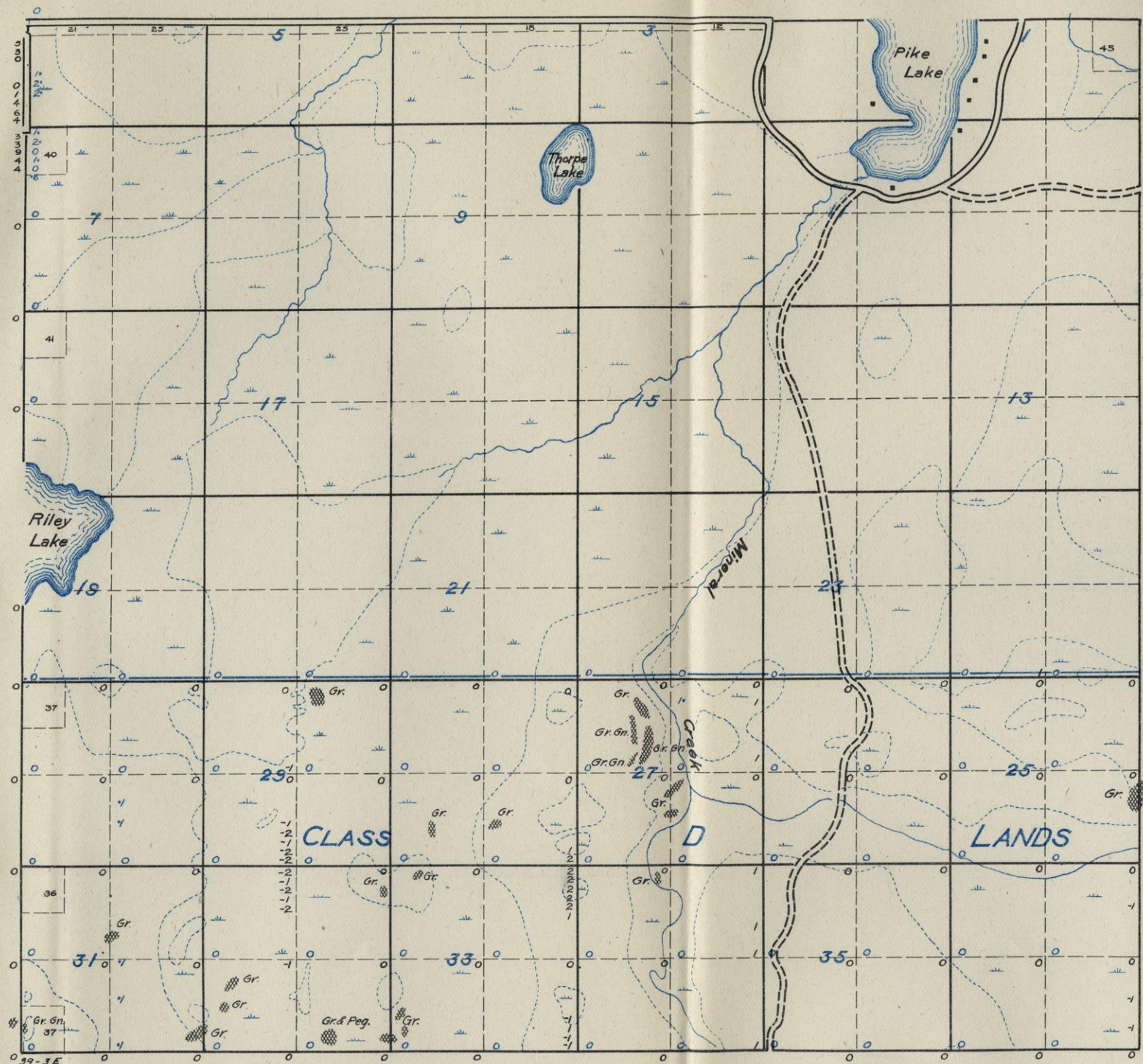

were found in this township, but these are undoubtedly due to the granite.

*Land Classification.*—A discussion of the principles of land classification employed in this work is given in Chapter V. All lands in the part of the township surveyed are placed in class D, because the evidence is fairly conclusive that they are underlain by granite.

*Exploration.*—Since all of the area surveyed is underlain by granite, no exploration can be recommended.

## TOWNSHIP 39 N., RANGE 2 E.

*Surface Features.*—The surface of this township is a monotonous succession of gently undulating glacial deposits. Elevations of more than 30 or 40 feet are extremely uncommon. Drainage is very poor and practically one-half of the township is swamp. A small depression in sections 29 and 30 is occupied by Sailor Lake, a very shallow body of water. On the north side of this lake a rock-cored hill rises to an elevation of about 40 feet.

The only road in this township which is passable for teams is the new one along the south side of the north tier of sections. This road is sandy but is well graded and crosses an easily drained country so it is good at all times. No timber remains in the township and there are no settlers nor any cleared land.

*Glacial Drift.*—Nearly all of the drift consists of ground moraine deposits but on the south side of section 12 is a low terminal moraine about a mile long and half a mile wide. The glacial drift both in the ground and terminal moraine consists principally of sand and gravel with some silt. Boulders are of common occurrence in all parts but are not numerous as a rule. The depth of the drift is not known except in the areas where rock exposures are found, but the wide distribution of these exposures suggests that it is generally shallow.

*General Geology.*—A number of outcrops of igneous rock were found at the points indicated on the map. The rocks exposed in sections 21, 29, 32, 34 and 36 are all light-colored, rather fine-grained biotite granites, with crystals varying from  $\frac{1}{8}$  to  $\frac{1}{4}$  inch in diameter. While all show gneissic structure it is as a rule poorly developed. North of Sailor Lake is an outcrop of rock which varies from a very fine-grained, dark colored hornblende schist with needle-like crystals and a distinctly schistose character, to a coarser garnetiferous hornblende granite gneiss in which the hornblende crystals are frequently  $\frac{1}{2}$  inch in length. Magnetite can be seen in these rocks with the hand lens, and hand specimens exhibit noticeable magnetic attraction. A short distance south of the N.  $\frac{1}{4}$  S. of 10 is a small exposure of hornblende granite gneiss, with crystals about  $\frac{1}{4}$  inch in length. This rock is composed mainly of hornblende and is very similar to the coarser rock described from the outcrop north of Sailor Lake. It is also magnetic in hand specimen.

*Magnetic Observations.*—A general discussion of magnetic observations and their significance is given in Chapter IV. Over all of the north and west part of the township fairly strong dip needly readings

# TOWN 39 N., R. 2E.

Survey Made in August, 1914

Under the Direction of  
**W. O. HOTCHKISS**, State Geologist  
AND  
**E. F. BEAN** and **O. W. WHEELWRIGHT**,  
in charge of Field Parties

BY  
**F. B. PLUMMER**, Chief of Party  
**R. N. HUNT**, Asst. Geologist  
**C. S. GWINN**, Asst. Geologist

**SYMBOLS AND ABBREVIATIONS.**  
The symbols and abbreviations used on this map are explained in Chapter II.

**TOWN AND RANGE LINES.**  
In constructing this map the south line of the township was laid off as a true east west line. The other boundary lines were then laid off with the lengths shown on the Land Survey plat. Some of the maps are therefore incorrect in shape but this is necessary because definite facts are lacking. The acreage of part of the lots in the north and west tier of sections is shown to give a check on the distances in these sections.

**LOCATIONS.**  
All locations are based on pacing traverses from government land corners. In many cases these were not found and it was necessary to continue the traverse several miles without a check. Locations of certain features may therefore be somewhat wrong. In such cases the feature sought may best be located by its relation to a stream, swamp, lake, or other feature shown on the map.

**PROFILES.**  
The locations of the profiles are shown on the map by dashed blue lines with black letters at the ends. Railroad profiles were furnished by the companies and show elevations of the ground rather than track in most cases; others are from road surveys by the State Highway Commission: most of them are hand level lines made by this Survey. Wherever possible the elevations above sea level are given. These elevations vary from 1050 to 1770 feet. A local datum plane was necessarily assumed in some cases. These cases are identifiable by the fact that the base line is always numbered 0.

**LAND CLASSIFICATION.**  
This is shown on the map by the blue letters. It is explained in the following township description and at length in chapter V.

**MAGNETIC DATA.**  
Dial compass readings are shown in blue figures. Eastward declinations are shown with a dot to the east and westward with a dot to west of the number. Dip needle readings are shown in black. All are positive except those preceded by the negative sign. All readings show deviation of needles from the normal reading of the instrument used. Normal readings are omitted from the map except at each quarter section corner. All abnormal readings are shown.

Traverses were made on lines indicated—usually the N-S section and quarter lines. Dip needle readings were taken each 50 paces, dial compass readings each 100 paces when sun permitted.

Magnetic lines are indicated by heavy black lines, solid where definite and dashed where doubtful.

**CAUTION:** Almost any kind of rock may be the cause of magnetic attraction. Do not fail to read the following description of this township, and also chapter IV., in which the magnetic attractions are discussed.

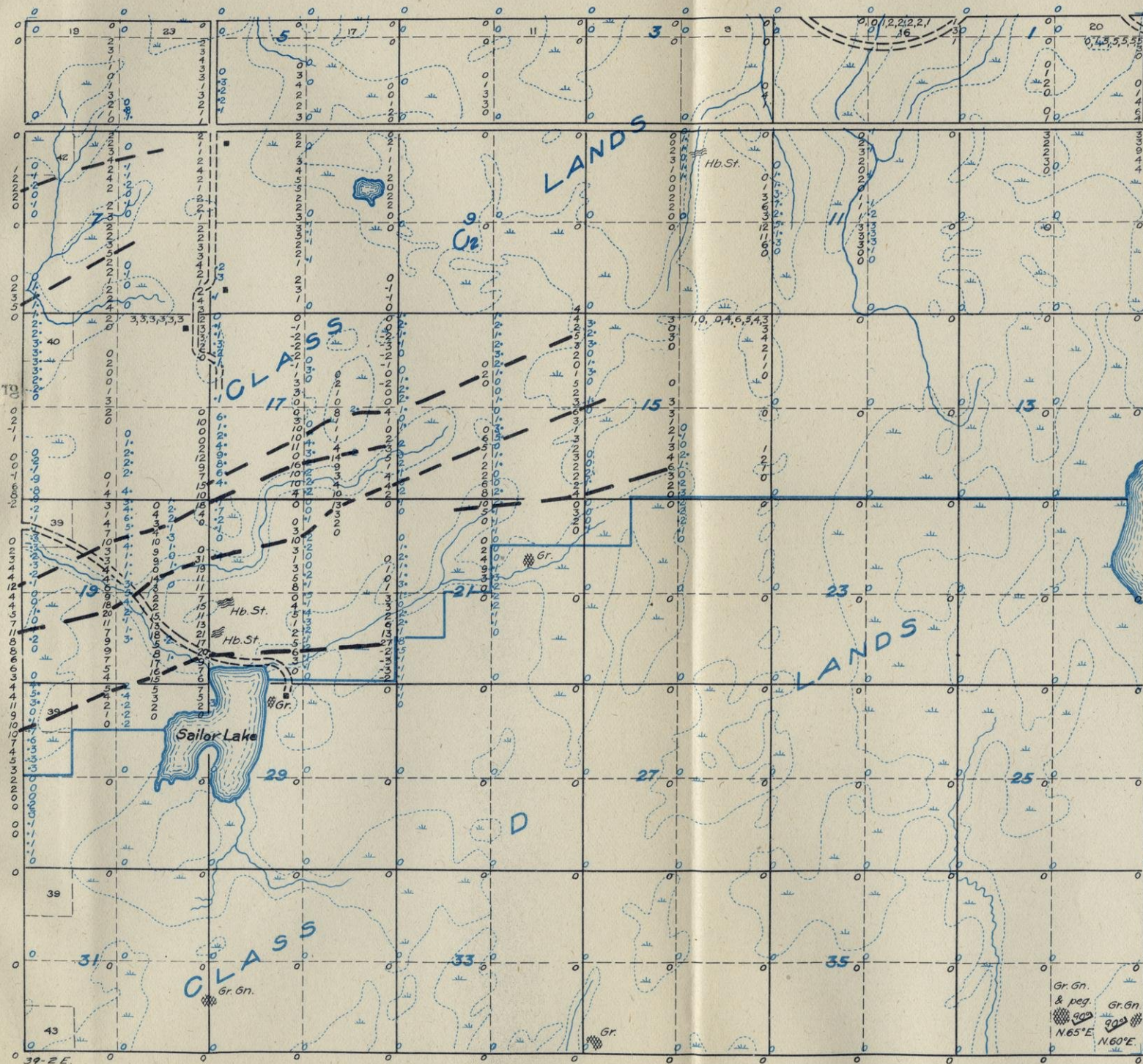



were obtained and the dial compass was deflected as much as  $9^{\circ}$  in places. These readings do not occur in definite magnetic lines, but form rather a magnetic area. The hornblende schist north of Sailor Lake outcrops in a place where the attraction is very strong and there is very little doubt but that this rock is responsible for most if not all the attraction in this township.

*Land Classification.*—For a general discussion of the principles of land classification employed in this work the reader is referred to Chapter V. Those lands in the township lying south of the magnetic area are placed in class D since evidence obtained in this and the adjoining townships shows with a reasonable degree of certainty that they are underlain by granite. All other lands are placed in class C2 whether magnetic or not. The attraction is apparently due to hornblende schists but there remains the possibility that iron formations may be associated with them.

*Exploration.*—From the facts above stated it is apparent that exploration in this township cannot be recommended. Even if iron formation were present as suggested, it would probably not be of a type likely to contain ore.

## TOWNSHIP 39 N., RANGE 1 E.

*Surface Features.*—That part of this township lying southeast of a line drawn from the north quarter post of section 1 to the southwest corner of section 33, is a nearly flat area of cut over land. West of this line, a great variety of topographic conditions are found. Along the wagon road in sections 2, 3, 10, and 11 some very rough terminal moraine topography occurs, and extending southwest from here into section 32 is a distinct narrow terminal moraine ridge several miles in length and but a few hundred feet in width. In sections 9, 16 and 17 is a large area of open swamp which was at one time occupied by a large lake. Immediately west of this are a series of esker-like ridges which probably served to dam the water of this lake. Another prominent topographic feature is a ridge extending from the northeast corner of section 4, in a winding course to the east quarter post of section 18. This ridge varies from a few hundred feet to nearly half a mile in width, and is parallel to the wagon road on the south side of sections 4 and 5 for a distance of about  $1\frac{1}{2}$  miles. In the vicinity of Fifield unequal glacial deposition and erosion by the Flambeau River have contributed to form an area of very rough topography. Another area of high rough ground is found in the extreme southwestern part of the township.

The accompanying profiles show these rougher areas where crossed by the wagon road. In all instances the grading of the roads has served to reduce to some extent the natural roughness along the line of the profile.

The roads in this township are few but are well graded and as the country is sandy they are usually in very good condition. Practically no timber remains in this township. There are but few settlers and all of these are in the immediate vicinity of Fifield.

*Glacial Drift.*—This township shows a great variety of glacial deposits. A narrow terminal moraine ridge runs from the northeast corner of section 15 to the southwest corner of section 28 and widens at each end to form a broad terminal moraine. On its north end the broader area of terminal moraine covers the west half of section 11, a portion of the east half of section 10, and the greater part of sections 2 and 1. East of this terminal moraine is an area of ground moraine partly covered by outwash deposits. Northwest of the ridge is a low flat area of ground moraine which is largely undrained. West of this area in sections 17, 20 and 29 is a series of eskers extending brokenly for a distance of about 3 miles northeast from the

south quarter post of section 29. A narrow terminal moraine with a width varying from a few hundred feet to one-half mile, extends from the N. E.  $\frac{1}{4}$  of section 4 nearly to the east quarter post of section 18. Another area of terminal moraine is found in section 5 and the northwest part of section 7 where it is divided by the Flambeau. A small, poorly defined outwash plain lies immediately south of the terminal moraine in sections 7, 8, 17 and 18.

All of the glacial deposits in this township consist largely of sand and gravel, with some boulders in the terminal and ground moraines. Locally boulders are numerous. The surface is characteristically sandy.

The drift varies greatly in thickness because of the variety of topographic conditions, but it is known in places to be very thin. In some of the terminal moraine areas it may be 150 feet or more in depth.

*General Geology.*—An outcrop of fine-grained granite gneiss occurs in the railroad cut just north of the mills in the village of Fifield. The gneissic structure is very well developed and strikes nearly east and west with a dip of  $85^{\circ}$  to the north. An outcrop of similar but somewhat coarser granite gneiss is found in the extreme southeastern part of section 34. Near the center of the N. W.  $\frac{1}{4}$  of section 26 is an outcrop of dense black hornblende schist made up almost entirely of hornblende in needle-like crystals about  $\frac{1}{4}$  inch in length. Some quartz and feldspar occur and magnetite is distinctly seen with the hand lens. This rock strongly attracts the compass needle. One quarter mile north of the southwest corner of section 10 are a number of large boulders of hornblende granite gneiss which show a variety of textures. Part of it is fine grained and composed of crystals of quartz, feldspar and hornblende. Other parts are composed almost entirely of crystals of hornblende, about an inch in length, and irregular masses of garnets. This rock is also magnetic. While the outcrops are few in number and their area is small it is believed that they represent the types which underlie most of the township.

*Magnetic Observations.*—A general discussion of magnetic observations and their significance is given in Chapter IV. A broad belt of attraction varying in width from  $\frac{3}{4}$  to  $1\frac{1}{2}$  miles extends across the township from section 30 to section 24 and is continuous for a distance of 4 miles into T. 39-2 E. Traverses across this area show several maxima but these cannot be connected up into lines continuous for any great distance. In general the attraction presents

such characteristics as would indicate that it is caused by an igneous formation or highly metamorphosed schist. In one instance in this township and also in T. 39-2 E. outcrops of hornblende schist are found in the places where the attractions are highest and it seems very probable that this rock is the cause of this broad belt of attraction. Milder irregular attraction is found over most of the northeastern part of this township, as shown on the accompanying plat. This is believed to be caused by a formation similar to that found in section 26.

*Land Classification.*—For a general discussion of the principles of land classification employed in this work the reader is referred to Chapter V. The lands in the immediate vicinity of the outcrop of granite gneiss at Fifield are placed in class D. In the southeastern part of the township are several sections which are quite certainly underlain by granite. These have been classed as D lands. All others are placed in class C2. While it is confidently believed that the attraction is caused by the hornblende schist, there remains the possibility that iron formation might be associated with it and it is therefore not thought advisable to put these magnetic lands in class D.

*Exploration.*—Exploration in this township cannot be recommended until additional information is obtained to indicate the presence an iron formation.

**TOWN 39 N., R. 1 E.**  
Survey Made in July, 1914

Under the Direction of  
**W. O. HOTCHKISS**, State Geologist  
AND  
**E. F. BEAN** and **O. W. WHEELWRIGHT**,  
in charge of Field Parties  
BY  
**F. B. PLUMMER**, Chief of Party  
**R. N. HUNT**, Asst. Geologist  
**C. S. GWINN**, Asst. Geologist

**SYMBOLS AND ABBREVIATIONS.**  
The symbols and abbreviations used on this map are explained in Chapter II.

**TOWN AND RANGE LINES.**  
In constructing this map the south line of the township was laid off as a true east west line. The other boundary lines were then laid off with the lengths shown on the Land Survey plat. Some of the maps are therefore incorrect in shape but this is necessary because definite facts are lacking. The acreage of part of the lots in the north and west tier of sections is shown to give a check on the distances in these sections.

**LOCATIONS.**  
All locations are based on pacing traverses from government land corners. In many cases these were not found and it was necessary to continue the traverse several miles without a check. Locations of certain features may therefore be somewhat wrong. In such cases the feature sought may best be located by its relation to a stream, swamp, lake, or other feature shown on the map.

**PROFILES.**  
The locations of the profiles are shown on the map by dashed blue lines with black letters at the ends. Railroad profiles were furnished by the companies and show elevations of the ground rather than track in most cases; others are from road surveys by the State Highway Commission; most of them are hand level lines made by this Survey. Wherever possible the elevations above sea level are given. These elevations vary from 1050 to 1770 feet. A local datum plane was necessarily assumed in some cases. These cases are identifiable by the fact that the base line is always numbered 0.

**LAND CLASSIFICATION.**  
This is shown on the map by the blue letters. It is explained in the following township description and at length in chapter V.

**MAGNETIC DATA.**  
Dial compass readings are shown in blue figures. Eastward declinations are shown with a dot to the east and westward with a dot to west of the number. Dip needle readings are shown in black. All are positive except those preceded by the negative sign. All readings show deviation of needles from the normal reading of the instrument used. Normal readings are omitted from the map except at each quarter section corner. All abnormal readings are shown.

Traverses were made on lines indicated—usually the N-S section and quarter lines. Dip needle readings were taken each 50 paces, dial compass readings each 100 paces when sun permitted.

Magnetic lines are indicated by heavy black lines, solid where definite and dashed where doubtful.  
**CAUTION:** Almost any kind of rock may be the cause of magnetic attraction. Do not fail to read the following description of this township, and also chapter IV., in which the magnetic attractions are discussed.

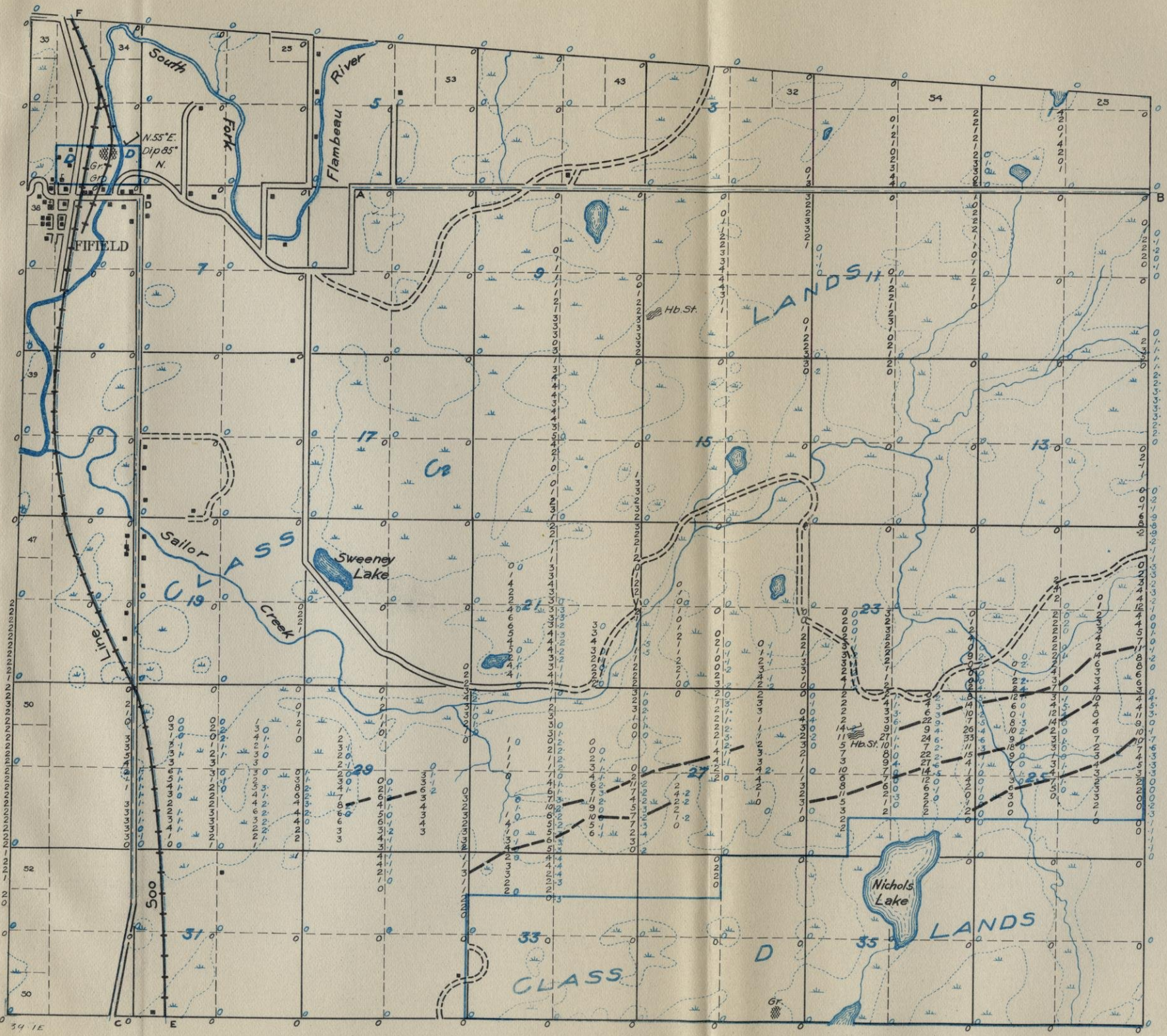

**PROFILES**  
VERTICAL SCALE: 1 space = 20'  
HORIZONTAL SCALE: same as map

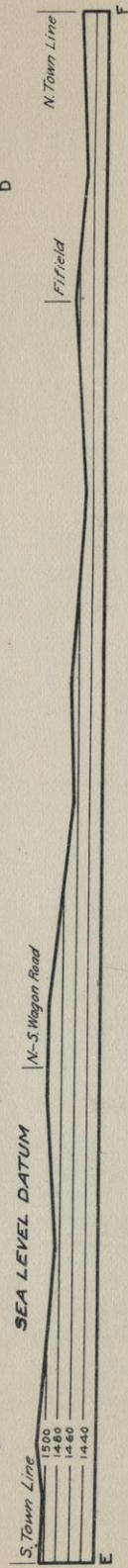
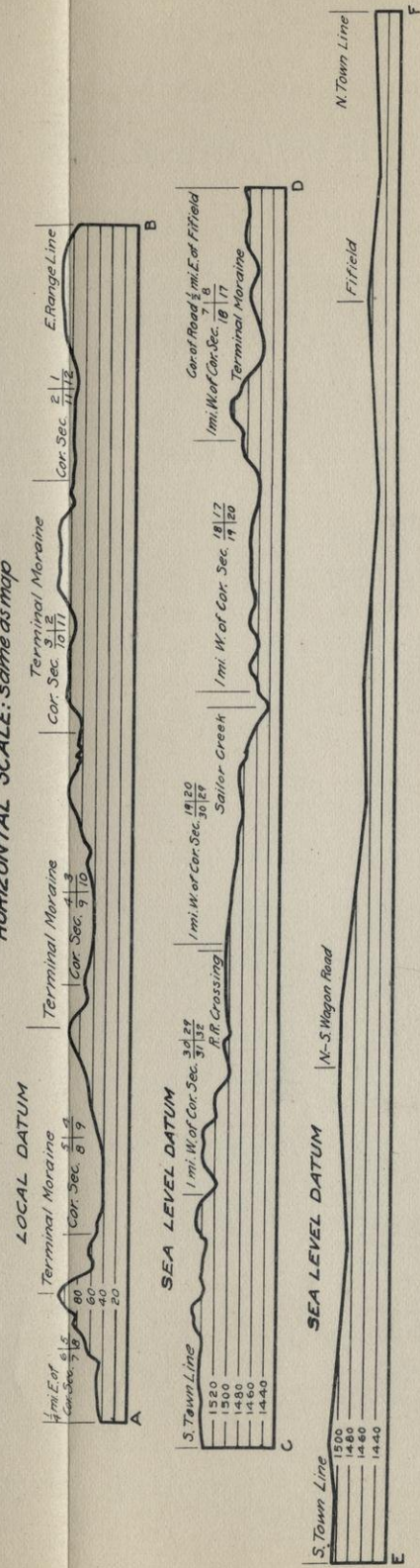

## TOWNSHIP 39 N., RANGE 1 W.

*Surface Features.*—A line drawn from the northeast corner of section 12 to the south quarter post of section 34 divides this township into two areas presenting distinctly different topographic features. Southeast of this line the country is rugged because of inequalities in glacial deposition and because of erosion by the South fork of the Flambeau River. Northwest of this line is a gently undulating area of very slight relief except along the north fork of the Flambeau River in the northwestern part of the township. Here again erosion has made the topography rather rough. In the flat area large swamps are common and a few small lakes lie in shallow depressions.

There is but one road in the township. This follows west along the south side of the north row of sections until it reaches the Flambeau River in section 4 where it turns and follows the general course of the stream to the township boundary in section 18. The eastern part of this road has been graded and is in fair condition, but the remainder is in poor condition except in dry weather. A branch road in section 3 runs north toward Park Falls. Most of the timber in this township has been removed, but scattered areas of hardwood still remain. Except along the road in the northern part of the township there are no settlers.

*Glacial Drift.*—The rougher area in the southeast part of the township is terminal moraine with characteristic knobs and kettles. The remainder is ground moraine. The material composing the drift is principally sand, gravel and boulders with a mantle of silt over the less eroded portions of the ground moraine areas. Along the larger streams there is much sand.

The depth of drift is probably not great except in the southeastern part. This statement is based on estimate rather than definite knowledge, since but one exposure of rock is known, and no wells have been put down to ledge. In the terminal moraine area in the southeastern part of the township it is probable that the depth is considerably over 100 feet.

*General Geology.*—One outcrop of fine-grained gray mica schist occurs in the northeast corner of section 15. This rock is a highly metamorphosed granite and has itself been intruded by coarse pink pegmatite. The schistosity strikes S. 60° W. and dips about 90°. Granite is exposed in the vicinity of Park Falls and Fifield and this outcrop suggests that the granite area extends into the northeast-

ern part of this township. Evidence obtained from the magnetic work makes it appear probable that most of the township is underlain by Huronian rocks.

*Magnetic Observations.*—A general discussion of magnetic observations and their significance is given in Chapter IV. In this township there are two distinct well-defined belts of magnetic attraction in addition to several areas of mild and less regular attraction. The longest and best defined magnetic line extends from the northern part of section 11 to section 18 and continues west into T. 39—2 W. Throughout its extent it is continuous and definite and is of such character that it probably indicates the presence of iron formation. The other line lies about  $1\frac{1}{2}$  miles south of this in sections 14, 15 and 31, and follows a parallel course. The attractions are milder and the line itself is not so well defined. The cause is undoubtedly the same as for the line to the north. Attractions in section 6 are traced into the township to the west, where they appear as a fairly good magnetic line. Along the eastern line of sections 24, 25 and 26 low dip needle readings were obtained and it will be noted that these are continuous into the township to the east, where they are shown to be caused in all probability by hornblende schist.

*Land Classification.*—A general discussion of the principles of land classification employed in this work is given in Chapter V. The land in the immediate vicinity of the granite outcrops is placed in class D. Lands lying along the definite magnetic lines are placed in class C1. All other lands are placed in class C2.

*Exploration.*—Since it is probable that the magnetic lines are due to iron formation a reasonable amount of exploration along these lines is warranted. In this and the township to the west, there is a considerable area of similar attractions. Results obtained at any point will tell definitely whether or not these are caused by iron formation and will give a good idea of the chance for finding ore in these two townships. The line in sections 9, 10, 11, 16 and 17 of this township appears to be somewhat more promising than the others although the magnetic attraction is rather high in places. Much of the work done in exploration for iron ore is wasted because of failure to make intelligent use of the geologic and magnetic data to be obtained by a careful preliminary survey, and because the geologic information given by the drill is not properly used as a guide for further work. The value of careful scientific

# TOWN 39 N., R. 1W.

Survey Made in July, 1914

Under the Direction of  
W. O. HOTCHKISS, State Geologist  
AND  
E. F. BEAN and O. W. WHEELWRIGHT,  
in charge of Field Parties  
BY

F. B. PLUMMER, Chief of Party  
R. N. HUNT, Asst. Geologist  
C. S. GWINN, Asst. Geologist

### SYMBOLS AND ABBREVIATIONS.

The symbols and abbreviations used on this map are explained in Chapter II.

### TOWN AND RANGE LINES.

In constructing this map the south line of the township was laid off as a true east west line. The other boundary lines were then laid off with the lengths shown on the Land Survey plat. Some of the maps are therefore incorrect in shape but this is necessary because definite facts are lacking. The acreage of part of the lots in the north and west tier of sections is shown to give a check on the distances in these sections.

### LOCATIONS.

All locations are based on pacing traverses from government land corners. In many cases these were not found and it was necessary to continue the traverse several miles without a check. Locations of certain features may therefore be somewhat wrong. In such cases the feature sought may best be located by its relation to a stream, swamp, lake, or other feature shown on the map.

### PROFILES.

The locations of the profiles are shown on the map by dashed blue lines with black letters at the ends. Railroad profiles were furnished by the companies and show elevations of the ground rather than track in most cases; others are from road surveys by the State Highway Commission; most of them are hand level lines made by this Survey. Wherever possible the elevations above sea level are given. These elevations vary from 1050 to 1770 feet. A local datum plane was necessarily assumed in some cases. These cases are identifiable by the fact that the base line is always numbered 0.

### LAND CLASSIFICATION.

This is shown on the map by the blue letters. It is explained in the following township description and at length in chapter V.

### MAGNETIC DATA.

Dial compass readings are shown in blue figures. Eastward declinations are shown with a dot to the east and westward with a dot to west of the number. Dip needle readings are shown in black. All are positive except those preceded by the negative sign. All readings show deviation of needles from the normal reading of the instrument used. Normal readings are omitted from the map except at each quarter section corner. All abnormal readings are shown.

Traverses were made on lines indicated—usually the N-S section and quarter lines. Dip needle readings were taken each 50 paces, dial compass readings each 100 paces when sun permitted.

Magnetic lines are indicated by heavy black lines, solid where definite and dashed where doubtful.

**CAUTION:** Almost any kind of rock may be the cause of magnetic attraction. Do not fail to read the following description of this township, and also chapter IV., in which the magnetic attractions are discussed.

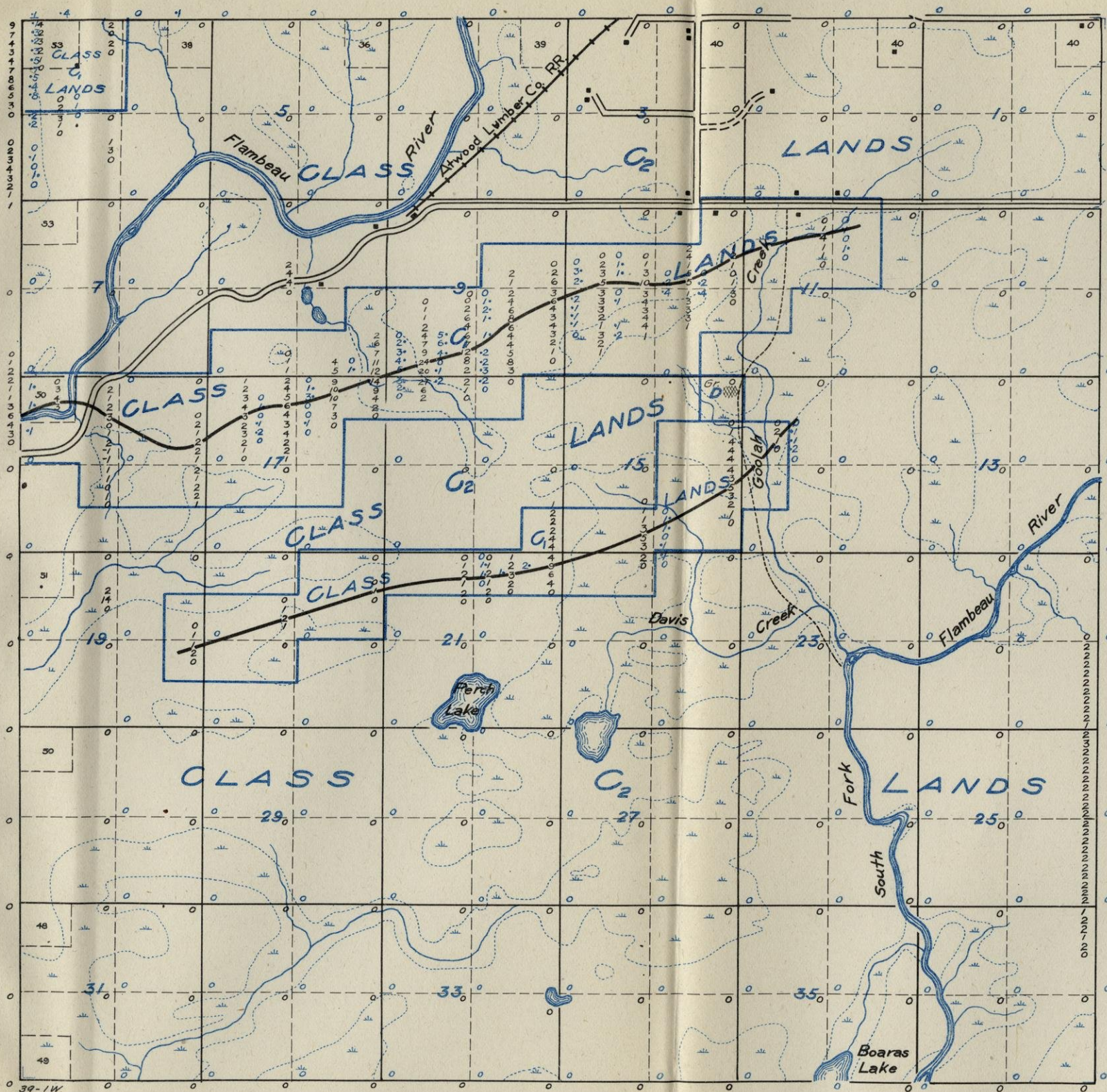



methods of exploration **therefore** cannot be too strongly emphasized. If exploration is **contemplated** in this township the discussion of this subject in chapter **VI** should be carefully studied.

## TOWNSHIP 39 N., RANGE 2 W.

*Surface Features.*—The topography is gently undulating in all that part of the township not lying close to the Flambeau River. Large swamps drained by sluggish streams are common. The Flambeau River crosses the township from east to west in a meandering course and turning north continues along the west line of the township into section 6. This stream has eroded its valley deeply into the drift deposits, making this part of the township very rough. The low ground between the north end of Long Lake and the river in section 19 strongly suggests that the course of the drainage was at one time out this way. The topography in sections 30, 31, and 32 is somewhat rougher than in the other parts of the township away from the river.

A road from Fifield runs along the south side of the Flambeau River and branches run south to the lakes. These are not graded but because of the sandy nature of the country are usually in passable condition. The remainder of the township is entirely without roads. There still remains a very large amount of standing timber which consists largely of hardwood with some hemlock. Except for the summer resorts on the lakes in the southwestern corner of the township, there are no settlers.

*Glacial Drift.*—Except for an area of terminal moraine, west of Long Lake in the southwest corner, the township is covered with ground moraine deposits. The materials composing the drift are sand and gravel with a good covering of silt except in the eroded areas along the river. Large bowlders are not of common occurrence. Lack of exposures and the fact that no wells reach the ledge or penetrate the surface to any considerable depth make a close estimate of the depth of surface impossible. It is thought that it will not prove to be over 100 feet.

*General Geology.*—There are no rock exposures in this township and very few in those adjoining. The geological inferences are based largely on the results of magnetic work. The wide distribution and character of the lines of magnetic attraction make it very probable that this township is largely an area of Huronian rocks. It is also probable that some granite is present.

*Magnetic Observations.*—A general discussion of magnetic observations and their significance is given in Chapter IV. The township is crossed by several nearly parallel belts of magnetic attraction

# TOWN 39 N., R. 2W.

Survey Made in August, 1914

Under the Direction of

W. O. HOTCHKISS, State Geologist  
AND

E. F. BEAN and O. W. WHEELWRIGHT,  
in charge of Field Parties

BY

F. B. PLUMMER, Chief of Party

R. N. HUNT, Asst. Geologist

C. S. GWINN, Asst. Geologist

## SYMBOLS AND ABBREVIATIONS.

The symbols and abbreviations used on this map are explained in Chapter II.

## TOWN AND RANGE LINES.

In constructing this map the south line of the township was laid off as a true east west line. The other boundary lines were then laid off with the lengths shown on the Land Survey plat. Some of the maps are therefore incorrect in shape but this is necessary because definite features are lacking. The acreage of part of the lots in the north and west tier of sections is shown to give a check on the distances in these sections.

## LOCATIONS.

All locations are based on pacing traverses from government land corners. In many cases these were not found and it was necessary to continue the traverse several miles without a check. Locations of certain features may therefore be somewhat wrong. In such cases the feature sought may best be located by its relation to a stream, swamp, lake, or other feature shown on the map.

## PROFILES.

The locations of the profiles are shown on the map by dashed blue lines with black letters at the ends. Railroad profiles were furnished by the companies and show elevations of the ground rather than track in most cases; others are from road surveys by the State Highway Commission; most of them are hand level lines made by this Survey. Wherever possible the elevations above sea level are given. These elevations vary from 1050 to 1770 feet. A local datum plane was necessarily assumed in some cases. These cases are identifiable by the fact that the base line is always numbered 0.

## LAND CLASSIFICATION.

This is shown on the map by the blue letters. It is explained in the following township description and at length in chapter V.

## MAGNETIC DATA.

Dial compass readings are shown in blue figures. Eastward declinations are shown with a dot to the east and westward with a dot to west of the number. Dip needle readings are shown in black. All are positive except those preceded by the negative sign. All readings show deviation of needles from the normal reading of the instrument used. Normal readings are omitted from the map except at each quarter section corner. All abnormal readings are shown.

Traverses were made on lines indicated—usually the N-S section and quarter lines. Dip needle readings were taken each 50 paces, dial compass readings each 100 paces when sun permitted.

Magnetic lines are indicated by heavy black lines, solid where definite and dashed where doubtful.

**CAUTION:** Almost any kind of rock may be the cause of magnetic attraction. Do not fail to read the following description of this township, and also chapter IV., in which the magnetic attractions are discussed.

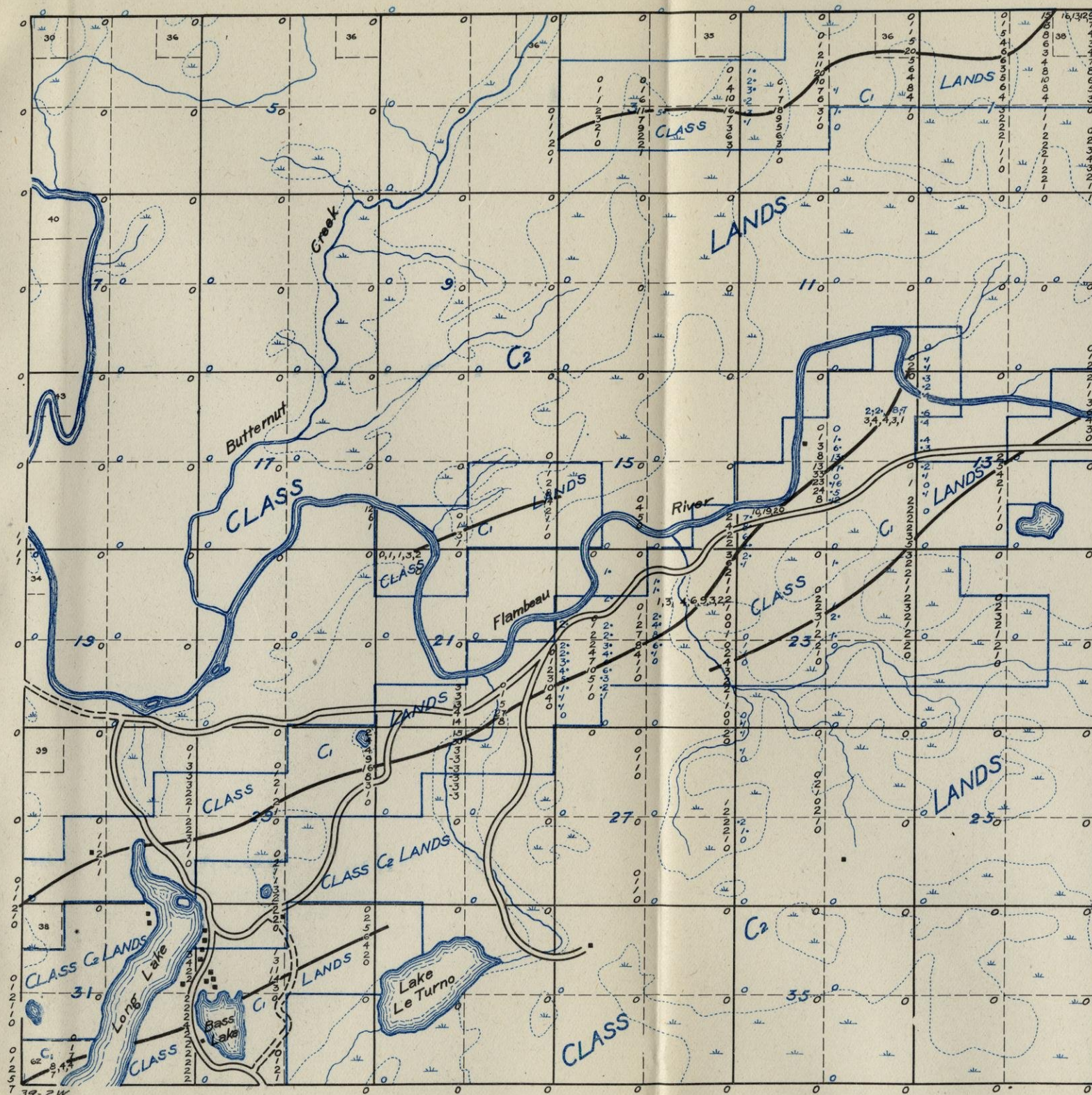

which trend in a direction about 30° south of west. As a rule the attraction is fairly uniform and of such character as to indicate strongly the presence of iron formation particularly when the extent of this attraction to the east and west is taken into consideration. The longest of these belts extends continuously across the township from the southwest corner of section 12 to the southwest corner of section 30. About  $\frac{1}{2}$  mile south of this in sections 13 and 23, is another definite belt which can be traced into the township to the east. A line of strong attraction occurs in sections 1, 2 and 3 and continues eastward into T. 40-1 W. Mild attraction occurs in sections 26 and 27 and a rather irregular area is found in sections 31 and 32.

*Land Classification.*—For a general discussion of the principles of land classification employed in this work the reader is referred to Chapter V. Lands along the magnetic lines are placed in class C1. Part of the township may be underlain by granite but there is no evidence to show this, so all other lands are placed in class C2.

*Exploration.*—While it is believed that the magnetic lines are due to the presence of iron formation the attractions are so strong that exploration along most of them is of doubtful advisability. If exploration is undertaken the most favorable places are believed to be those where the lines are weak, as in the southwest corner of the township or in sections 13 and 23. It should be remembered that these strong lines may parallel less altered formations which could be found only by drilling a number of holes across the line and for some distance on either side. Much of the work done in exploration for iron ore is wasted because of failure to make intelligent use of the geologic and magnetic data to be obtained by a careful preliminary survey, and because the geologic information given by the drill is not properly used as a guide for further work. The value of careful scientific methods of exploration therefore cannot be too strongly emphasized. If exploration is contemplated in this township the discussion of this subject in Chapter VI should be carefully studied.

## TOWNSHIP 39 N., RANGE 3 W.

*Surface Features.*—The western half of this township is gently undulating and characterized by sluggish drainage and much swampy ground. The remainder is better drained and presents a somewhat rougher surface but is about the same in elevation. In the southeastern corner are a number of depressions occupied by lakes. The Flambeau River flows through a narrow valley with steep banks varying from 20 to 40 feet in height. The general elevation of the uplands is about 75 to 100 feet above the river. The elevation of the river varies from 1,350 feet at the south township line to nearly 1,380 feet above sea level where it enters the township at the southeast corner of section 1. On both sides of the river erosion has cut into the surface considerably.

There are no graded roads in this township at the present time but one is in process of construction from Draper to the Hanson farm in the center of section 14. The old tote road from Hanson's Spur to the Flambeau River is practically impassable at all times. The roads on the east side of the river are in fairly good condition. Considerable hardwood still remains in this township. There are very few settlers at present.

*Glacial Deposits.*—The more level western part of the township is covered with ground moraine which shows very poorly marked terminal moraine characteristics in the west side of sections 18, 19 and 30. The central and northeastern parts are somewhat rougher and might be classed as weak terminal moraine, while the lake region in the southeastern part is distinctly terminal moraine. The drift consists of silt, sand, and gravel with bowlders over the entire township. The proportions of the constituents vary slightly locally. There is no information bearing upon the thickness of the glacial drift but indications are that it will prove to be deep. The estimated depth is from 100 to 150 feet as the minimum.

*General Geology.*—No rock outcrops are found in this township nor in those adjoining. A few exposures of granite are found to the west and it is probable that granite occurs in the west side of this township. A magnetic line from the east extends into this township and most probably indicates the presence of iron formation and other Huronian sediments.

*Magnetic Observations.*—A general discussion of magnetic observations and their significance is given in Chapter IV. In the southeast

TOWN 39 N., R. 3W.

Survey Made in September, 1914

Under the Direction of

W. O. HOTCHKISS, State Geologist

AND

E. F. BEAN and O. W. WHEELWRIGHT,  
in charge of Field Parties

BY

H. J. ALLEN, Chief of Party

C. R. SCHROYER, Asst. Geologist

E. L. JAY, Asst. Geologist

SYMBOLS AND ABBREVIATIONS.

The symbols and abbreviations used on this map are explained in Chapter II.

TOWN AND RANGE LINES.

In constructing this map the south line of the township was laid off as a true east west line. The other boundary lines were then laid off with the lengths shown on the Land Survey plat. Some of the maps are therefore incorrect in shape but this is necessary because definite facts are lacking. The acreage of part of the lots in the north and west tier of sections is shown to give a check on the distances in these sections.

LOCATIONS.

All locations are based on pacing traverses from government land corners. In many cases these were not found and it was necessary to continue the traverse several miles without a check. Locations of certain features may therefore be somewhat wrong. In such cases the feature sought may best be located by its relation to a stream, swamp, lake, or other feature shown on the map.

PROFILES.

The locations of the profiles are shown on the map by dashed blue lines with black letters at the ends. Railroad profiles were furnished by the companies and show elevations of the ground rather than track in most cases; others are from road surveys by the State Highway Commission; most of them are hand level lines made by this Survey. Wherever possible the elevations above sea level are given. These elevations vary from 1050 to 1770 feet. A local datum plane was necessarily assumed in some cases. These cases are identifiable by the fact that the base line is always numbered 0.

LAND CLASSIFICATION.

This is shown on the map by the blue letters. It is explained in the following township description and at length in chapter V.

MAGNETIC DATA.

Dial compass readings are shown in blue figures. Eastward declinations are shown with a dot to the east and westward with a dot to west of the number. Dip needle readings are shown in black. All are positive except those preceded by the negative sign. All readings show deviation of needles from the normal reading of the instrument used. Normal readings are omitted from the map except at each quarter section corner. All abnormal readings are shown.

Traverses were made on lines indicated—usually the N-S section and quarter lines. Dip needle readings were taken each 50 paces, dial compass readings each 100 paces when sun permitted.

Magnetic lines are indicated by heavy black lines, solid where definite and dashed where doubtful.

CAUTION: Almost any kind of rock may be the cause of magnetic attraction. Do not fail to read the following description of this township, and also chapter IV., in which the magnetic attractions are discussed.

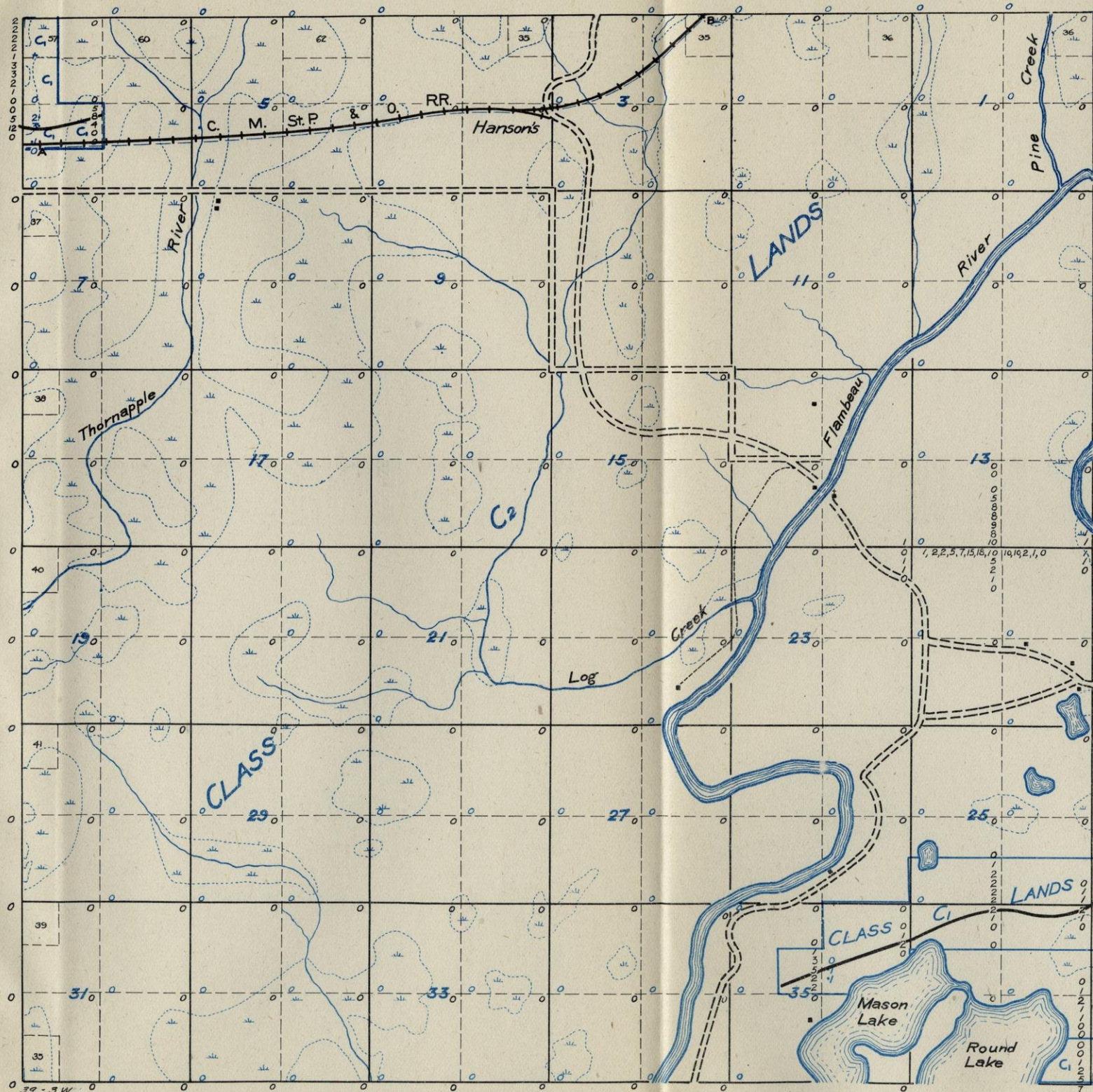

PROFILE

VERTICAL SCALE: 1 space = 20'  
HORIZONTAL SCALE: same as map

SEA LEVEL DATUM

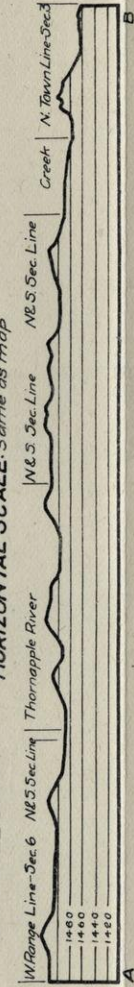

corner of the township is a line of mild attraction which is a continuation of that found to the east in T. 39-2 W. Along the line between sections 13 and 24 is an irregular area of attraction which does not appear to be continuous with any line found to the east. In the northwest corner of the township moderately strong attraction was found extending west into T. 39-4 W., where it is continuous for some miles.

*Land Classification.*—For a general discussion of the principles of land classification employed in this work the reader is referred to Chapter V. While the magnetic lines found are not of the most regular and definite kind, most of the attractions are probably caused by iron formation, and the lands on the lines of attraction are placed in class C1. Because of lack of attraction and the absence of any definite information all other lands are placed in class C2.

*Exploration.*—A moderate amount of exploration may be warranted on the magnetic lines. The line in the southeast corner is mild in character and continuous for a long distance to the northeast. It is believed to be the best place to explore. The line in section 6 is continuous for a long distance west. While the attractions are a little higher than the others they are still moderate and there is therefore little choice between them. Much of the work done in exploration for iron ore is wasted because of failure to make intelligent use of the geologic and magnetic data to be obtained by a careful preliminary survey, and because the geologic information given by the drill is not properly used as a guide for further work. The value of careful scientific methods of exploration therefore cannot be too strongly emphasized. If exploration is contemplated in this township the discussion of this subject in Chapter VI should be carefully studied.

## TOWNSHIP 39 N., RANGE 4 W.

*Surface Features.*—Except for a strip a mile wide on the north side and a similar strip from 1 to 2 miles wide on the west side, the topography of this township is characteristically flat or gently undulating, and the drainage is very poor. Some minor roughness is found in the east side of sections 24, 25 and 36 but this is not a prominent feature. It is only in the northwestern and southwestern parts that relief is great or that the topography would be considered rough. The northwestern part is characterized by rough knob and kettle topography. In the southwestern part the elevations are in the form of linear ridges having considerable relief but usually with smooth slopes. The accompanying profile along the C. St. P. M. & O. R. R. shows a gentle rise in elevation from the west to the east side of the township, which marks the ascent to the divide between the Chippewa and Flambeau drainage areas.

This township is practically without roads except for a well graded road which is now nearly complete from Draper to the west line. All others shown on the map are tote roads to logging camps and are usually travelled only with difficulty.

The southern and southeastern parts still have considerable hardwood and hemlock timber, and scattering patches occur elsewhere in the township. The swamps as a rule have no good timber. At present there are practically no settlers in the township outside the village of Draper but undoubtedly the rich soil will attract them in considerable numbers now that the timber is being removed.

*Glacial Drift.*—The elevated ridges in the southwestern part and the rough knob and kettle area in sections 3, 4, 5 and 6 are terminal moraine deposits. The drift consists of silt, sand, gravel and boulders but in the northern sections it is more sandy than elsewhere. The rougher parts of sections 24, 25 and 36 might also be classed as weak terminal moraines. The remainder of the township is ground moraine and the character of the drift does not differ essentially from that in the southwestern terminal moraine area but is more silty than in the northwestern part.

There is no information bearing on the depth of the glacial drift but it is assumed that it is nearly 100 feet in all parts of the township and is undoubtedly greater in the elevated southwestern area.

*General Geology.*—There are no outcrops in this township, so that except for the magnetic data little information is available as to the character of the underlying formations. However, the results of magnetic work and the evidence found in nearby townships make



TOWN 39 N., R. 4W.

Survey Made in July, 1914

Under the Direction of  
W. O. HOTCHKISS, State Geologist

AND  
E. F. BEAN and O. W. WHEELWRIGHT,  
in charge of Field Parties

BY  
H. J. ALLEN, Chief of Party

C. R. SCHROYER, Asst. Geologist

E. L. JAY, Asst. Geologist

SYMBOLS AND ABBREVIATIONS.

The symbols and abbreviations used on this map are explained in Chapter II.

TOWN AND RANGE LINES.

In constructing this map the south line of the township was laid off as a true east west line. The other boundary lines were then laid off with the lengths shown on the Land Survey plat. Some of the maps are therefore incorrect in shape but this is necessary because definite facts are lacking. The acreage of part of the lots in the north and west tier of sections is shown to give a check on the distances in these sections.

LOCATIONS.

All locations are based on pacing traverses from government land corners. In many cases these were not found and it was necessary to continue the traverse several miles without a check. Locations of certain features may therefore be somewhat wrong. In such cases the feature sought may best be located by its relation to a stream, swamp, lake, or other feature shown on the map.

PROFILES.

The locations of the profiles are shown on the map by dashed blue lines with black letters at the ends. Railroad profiles were furnished by the companies and show elevations of the ground rather than track in most cases; others are from road surveys by the State Highway Commission; most of them are hand level lines made by this Survey. Wherever possible the elevations above sea level are given. These elevations vary from 1050 to 1770 feet. A local datum plane was necessarily assumed in some cases. These cases are identifiable by the fact that the base line is always numbered 0.

LAND CLASSIFICATION.

This is shown on the map by the blue letters. It is explained in the following township description and at length in chapter V.

MAGNETIC DATA.

Dial compass readings are shown in blue figures. Eastward declinations are shown with a dot to the east and westward with a dot to west of the number. Dip needle readings are shown in black. All are positive except those preceded by the negative sign. All readings show deviation of needles from the normal reading of the instrument used. Normal readings are omitted from the map except at each quarter section corner. All abnormal readings are shown.

Traverses were made on lines indicated—usually the N-S section and quarter lines. Dip needle readings were taken each 50 paces, dial compass readings each 100 paces when sun permitted.

Magnetic lines are indicated by heavy black lines, solid where definite and dashed where doubtful.

CAUTION: Almost any kind of rock may be the cause of magnetic attraction. Do not fail to read the following description of this township, and also chapter IV., in which the magnetic attractions are discussed.

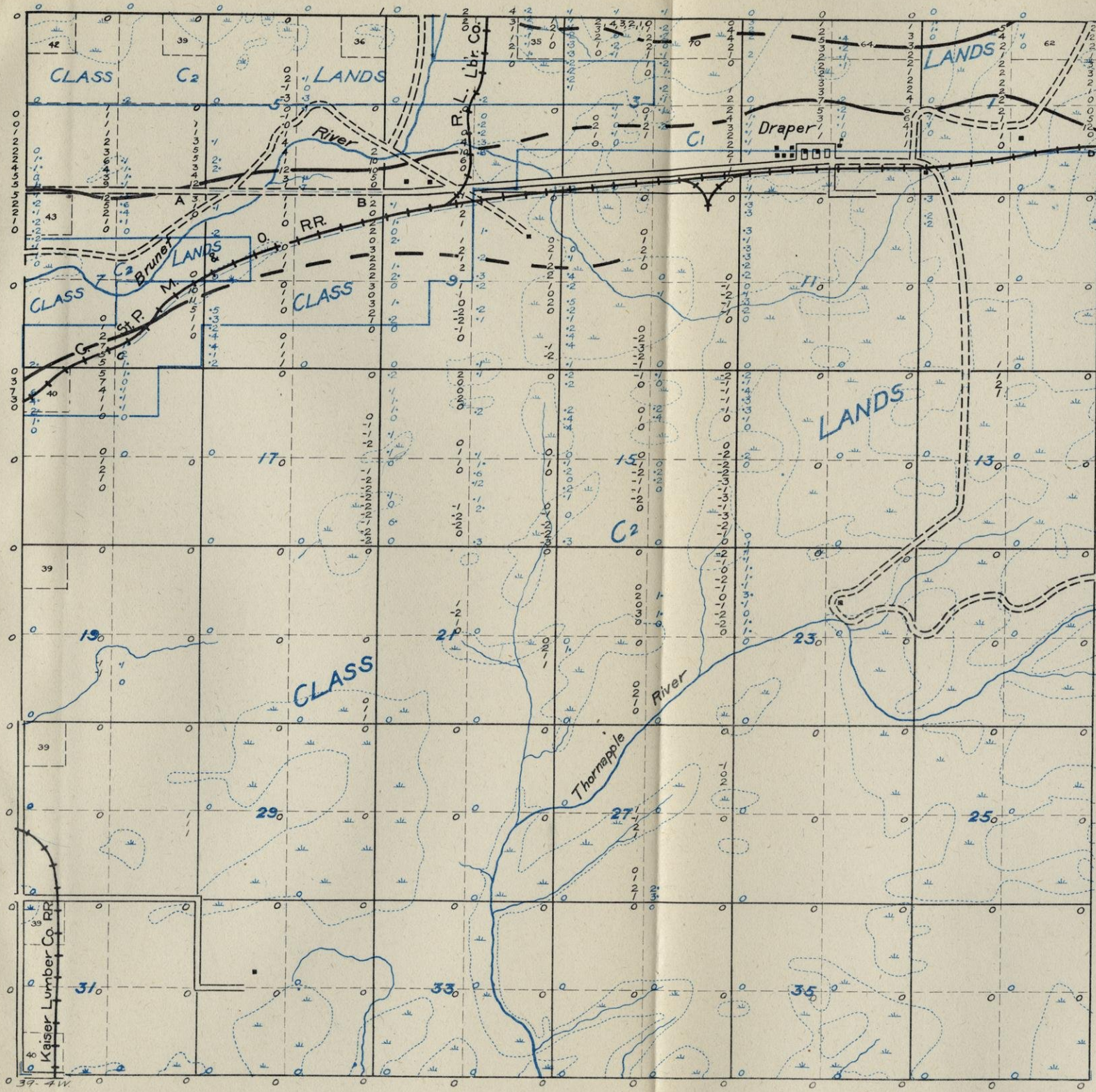

PROFILE  
VERTICAL SCALE: 1 space = 20'  
HORIZONTAL SCALE: Same as map

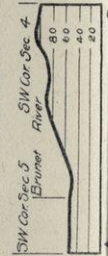

LOCAL DATUM

SEA LEVEL DATUM

E. Range Line

Draper

Creek

Near N-S 1/4 Line Sec. 7

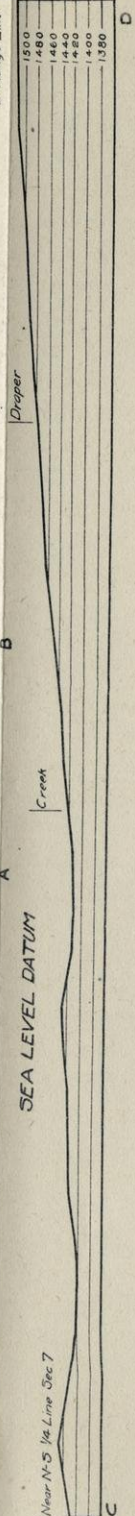

it appear probable that **most of that part** of the township where positive magnetic attractions are found is an area of Huronian rocks. South of this it is assumed that the rocks are largely igneous.

*Magnetic Observations.*—A general discussion of magnetic observations and their significance will be found in Chapter IV. Magnetic attraction is found generally over the entire northern two-thirds of the township but with the exception of some fairly-well defined lines in the northern tier of sections it is very irregular and of such a nature that it might be caused by a mildly magnetic igneous formation. Fairly well defined lines, however, are found in the northern part of the township and extend into the adjoining townships to the east and west. Passing to the west they become less definite in T. 39-5 W. Toward the east they become rather more definite. It is possible that this attraction may be caused by an iron formation but it is also possible that it is caused by schists such as are found outcropping on the Chippewa River some miles to the north.

*Land Classification.*—For a general discussion of the principles of land classification employed in this work the reader is referred to Chapter V. Lands on the better defined magnetic lines in the northern part of the township are placed in class C1 although not considered as among the most favorable of this class. All other lands in this township are placed in class C2 for the reason that there is no information on which to base a positive statement of the character of the underlying rocks.

*Exploration.*—A moderate amount of exploration in this township is recommended for the purpose of determining the mineral possibilities of the great area of magnetic attraction crossing the north side of this township. The most favorable place is along the better defined magnetic lines in sections 1, 2, 4, 5 and 6. It would be advisable to drill for some distance on either side of the maximum attraction in order to determine definitely whether or not iron formation is present. Exploration along these lines in the township east would determine whether or not they indicate the presence of an iron formation in this township. Much of the work done in exploration for iron ore is wasted because of failure to make intelligent use of the geologic and magnetic data to be obtained by a careful preliminary survey, and because the geologic information given by the drill is not properly used as a guide for further work. The value of careful scientific methods of exploration therefore cannot be too strongly emphasized. If exploration is contemplated in this township the discussion of this subject in Chapter VI should be carefully studied

## TOWNSHIP 39 N., RANGE 5 W.

*Surface Features.*—Nearly all of that part of the township north and west of the Brunet River is flat or very gently undulating and of low relief. Most of the surface is swampy and there are a number of small lakes occupying small depressions. East of the Brunet River the ground is higher and better drained and is characterized by large hills with gentle slopes. The southeastern part is especially high rising 175 feet above the level of the Brunet River where crossed by the wagon road in section 27. The accompanying profile A-D shows these differences of elevation very clearly. The other profiles show very well the general nature of the surface.

Roads in the township are few and except for short stretches are in poor shape for travel, a condition which is being remedied very slowly. Considerable hardwood remains in the higher ground in the southern part of the township and there is some in the central part. Logging operations are still very active. Settlers are few and settlement goes on slowly largely because of the poor condition of the roads.

*Glacial Drift.*—The high ground east of the Brunet River and in section 1 is terminal moraine. All the rest is ground moraine covered to a very considerable extent with outwash deposits in irregular patches. Most of the surface along the west side of the Brunet river and near the village of Winter is covered by outwash. The drift in the terminal and ground moraine areas consists of silt, sand and gravel, with numerous boulders in places. The outwash consists of sand and gravel and is characterized by the absence of boulders.

There is no information to show the depth of the drift, as the wells are all very shallow. It is assumed, however, that the drift will exceed 100 feet in thickness in most parts of the township and east of the Brunet River will undoubtedly be thicker than this.

*General Geology.*—No exposures of rock were found in this township and exposures in adjoining townships are very few, so that little is definitely known regarding the character of the underlying rocks. About  $1\frac{1}{2}$  miles west of the west township line granites and hornblende schists are exposed on the Chippewa River. The apparent strike of these schists is nearly east and west and they may extend over into this township. Evidence obtained from the magnetic survey suggests that most of the township is in an area of Huronian rocks which probably are for the most part highly metamorphosed

TOWN 39 N., R. 5W.

Survey Made in July, 1914

Under the Direction of  
W. O. HOTCHKISS, State Geologist  
AND  
E. F. BEAN and O. W. WHEELWRIGHT,  
in charge of Field Parties

BY  
H. J. ALLEN, Chief of Party  
C. R. SCHROYER, Asst. Geologist  
E. L. JAY, Asst. Geologist

**SYMBOLS AND ABBREVIATIONS.**  
The symbols and abbreviations used on this map are explained in Chapter II.

**TOWN AND RANGE LINES.**  
In constructing this map the south line of the township was laid off as a true east west line. The other boundary lines were then laid off with the lengths shown on the Land Survey plat. Some of the maps are therefore incorrect in shape but this is necessary because definite facts are lacking. The acreage of part of the lots in the north and west tier of sections is shown to give a check on the distances in these sections.

**LOCATIONS.**  
All locations are based on pacing traverses from government land corners. In many cases these were not found and it was necessary to continue the traverse several miles without a check. Locations of certain features may therefore be somewhat wrong. In such cases the feature sought may best be located by its relation to a stream, swamp, lake, or other feature shown on the map.

**PROFILES.**  
The locations of the profiles are shown on the map by dashed blue lines with black letters at the ends. Railroad profiles were furnished by the companies and show elevations of the ground rather than track in most cases; others are from road surveys by the State Highway Commission; most of them are hand level lines made by this Survey. Wherever possible the elevations above sea level are given. These elevations vary from 1050 to 1770 feet. A local datum plane was necessarily assumed in some cases. These cases are identifiable by the fact that the base line is always numbered 0.

**LAND CLASSIFICATION.**  
This is shown on the map by the blue letters. It is explained in the following township description and at length in chapter V.

**MAGNETIC DATA.**  
Dial compass readings are shown in blue figures. Eastward declinations are shown with a dot to the east and westward with a dot to west of the number. Dip needle readings are shown in black. All are positive except those preceded by the negative sign. All readings show deviation of needles from the normal reading of the instrument used. Normal readings are omitted from the map except at each quarter section corner. All abnormal readings are shown.

Traverses were made on lines indicated—usually the N-S section and quarter lines. Dip needle readings were taken each 50 paces, dial compass readings each 100 paces when sun permitted.

Magnetic lines are indicated by heavy black lines, solid where definite and dashed where doubtful.

**CAUTION:** Almost any kind of rock may be the cause of magnetic attraction. Do not fail to read the following description of this township, and also chapter IV., in which the magnetic attractions are discussed.

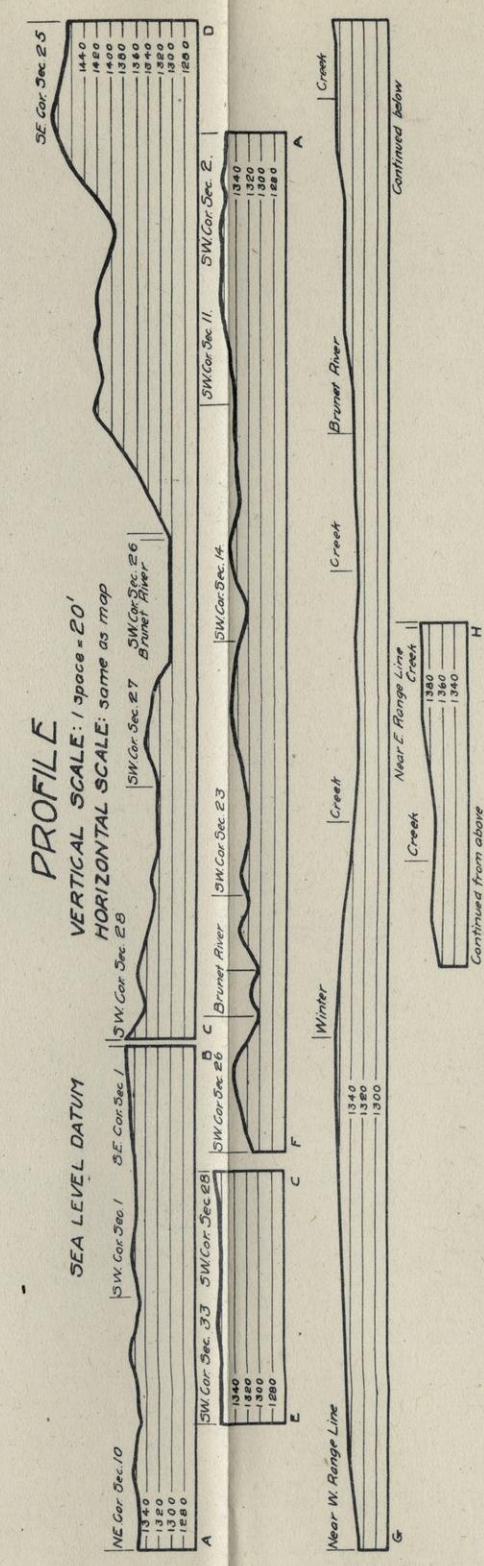
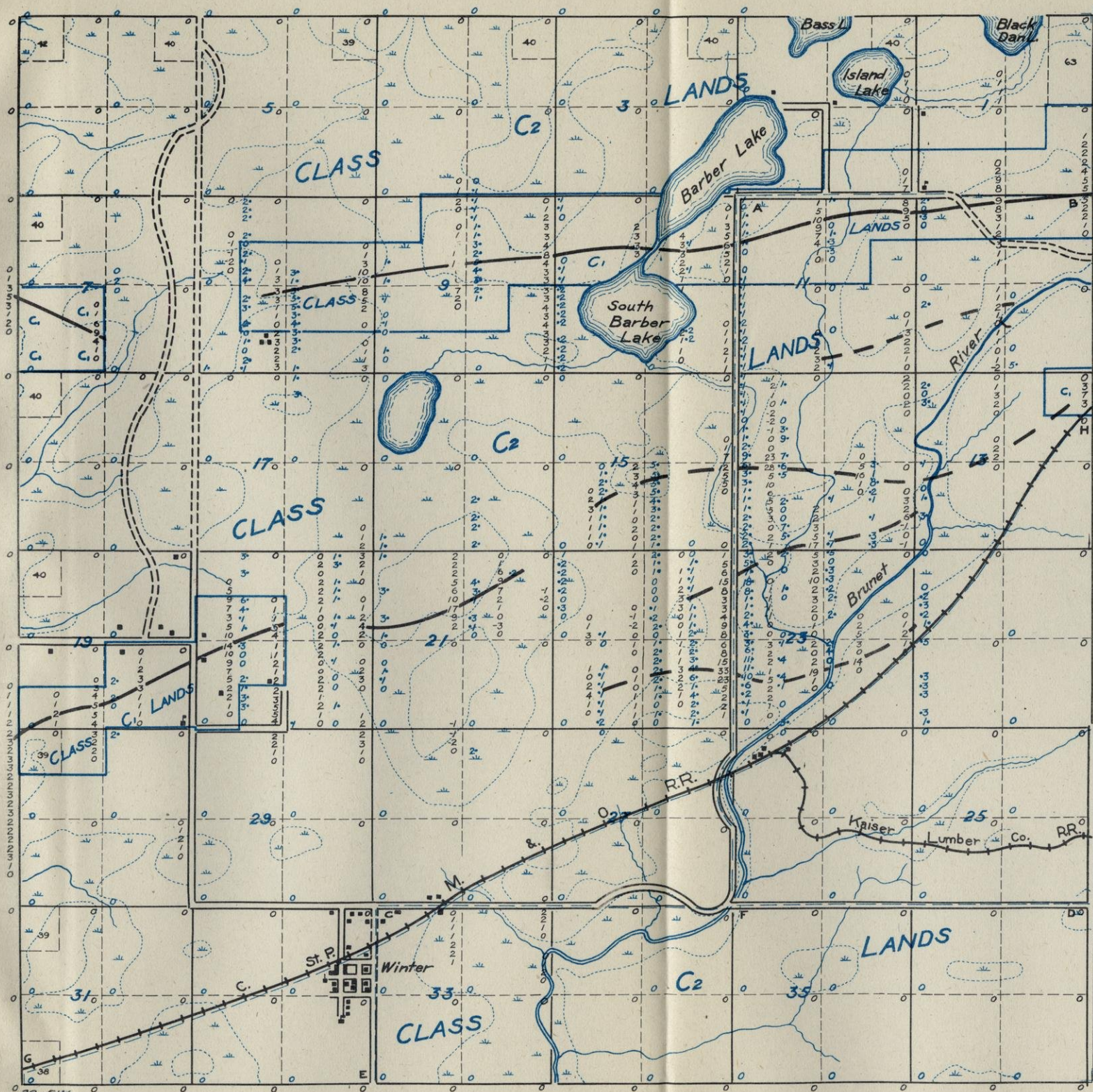

schists but may contain some iron formation. Granites probably occupy the southern and the northwestern parts of the township but it is not possible to state these views as facts.

*Magnetic Observations.*—A general discussion of magnetic observations and their significance is given in Chapter IV. Magnetic attraction of varying intensity was found over a large portion of the northern two-thirds of this township but of such a nature that in most of the area definite magnetic lines cannot be drawn. A well-defined line extends across sections 8, 9, 10, 11 and 12 and into T. 39-4 W., and after a break continues across section 7 and extends several miles into T. 39-6 W. South of this line there is more irregularity in the attractions.

*Land Classification.*—For a general discussion of the principles of land classification employed in this work the reader is referred to Chapter V. Lands on the better defined magnetic lines in the northern and western parts of the township are placed in class C1, although not considered among the best lands of this class. All other lands in this township are placed in class C2, because of the lack of definite information as to the character of the rocks, and the fact that nothing but irregular magnetic attractions were found.

*Exploration.*—From a geological standpoint exploration is not advised. Since there is a very large area in this and the townships to the east and west which show these magnetic attractions it may appear advisable to determine definitely the mineral possibilities on these lines. Probably the most favorable place in this township for such a test is along the line in sections 8, 9, 10, 11 and 12. A relatively small amount of drilling would give information which would determine whether or not this great magnetic area offers any promise of iron ore. Much of the work done in exploration for iron ore is wasted because of failure to make intelligent use of the geologic and magnetic data to be obtained by a careful preliminary survey, and because the geologic information given by the drill is not properly used as a guide for further work. The value of careful scientific methods of exploration therefore cannot be too strongly emphasized. If exploration is contemplated in this township the discussion of this subject in chapter VI should be carefully studied.

## TOWNSHIP 39 N., RANGE 6 W.

*Surface Features.*—The surface of this township is gently rolling, varying to flat in places, and large undrained areas are quite common. Except along the Chippewa River there is no marked relief. This stream has cut very deeply into the glacial deposits, and in traveling along the wagon road which follows this stream the impression of very rough topography is obtained. The valley is usually very narrow and about 75 feet below the general level of the country. Well-defined river terraces are developed in places. The accompanying profiles, give a fair idea of the topography in that portion of the township near the river. Away from the river, slopes are usually more gentle and relief less marked.

Roads are entirely lacking except along the Chippewa River and east through sections 23 and 24, and those that do exist are in rather poor condition. In the area west of the river considerable hardwood remains and lumbering is still being carried on. The only settlement is along the roads indicated.

*Glacial Drift.*—The entire township is covered by a deposit of ground moraine which is dissected along the course of the Chippewa. The materials making up the drift are mostly silt, with some sand and gravel, and numerous boulders. Sand is a prominent constituent in the eroded area along the course of the Chippewa River.

The depth of the drift away from the Chippewa River is probably not more than 100 feet as a rule but in some of the higher parts of the township it may prove to be somewhat greater. Rock is exposed in the northwestern corner where there appears to be a very shallow covering of drift. The Chippewa River has eroded through to ledge near the center of section 23.

*General Geology.*—A few hundred feet north of the bridge over the Chippewa River in section 23 are two small exposures of rock. The most northerly one consists of a rather fine-grained hornblende schist having crystals of about  $\frac{1}{4}$  inch in length. Schistosity is well developed and has the appearance of possibly representing bedding in an originally sedimentary formation. The strike is nearly east and west and the dip about  $75^{\circ}$  to the south. A short distance south of this is a rounded knob of moderately coarse grained pink granite exposed in the bed of the river at low water stages. The relations between these two types of rocks are not shown but it seems probable that the granite is intruded into the schist.

In sections 5, 6 and 7 are a few exposures of a pink to reddish quartzite which is indetical with the Barron formation found 10 or more miles to the southwest. On the township line about 500 paces east of the northwest corner of section 6 a bluff 30 or 40 feet high, having a steep northerly slope, shows two small outcrops of reddish quartzite and following along the bluff into section 31 of the township to the north a number of other exposures are found. The rock in section 6 is a thoroughly cemented quartz sand having occasional pebbles of quartz as large as a pea. The bedding, which is thin, strikes N. 70° E. and dips 70° to 80° south. The rock is cross-bedded and considerably fractured. Blocks of quartzite lying on the surface indicate the presence of the ledge near the N. E. corner of section 6. The same condition is found at the southeast corner of this section. Along the small creek in the N. W.  $\frac{1}{4}$  of section 5 quartzite is exposed in several places. The strike and dip are well shown as a rule. In contrast with the exposures along the north township line the quartzite here dips north at an angle of about 15°. The rock is pinkish in color, fairly well cemented and thinly and evenly bedded. It is very evident that there is here a small syncline in the quartzite. Probably all of sections 5 and 6, the north half of sections 7 and 8, and possibly a part of the west half of section 4, are underlain by this rock. There is no evidence for its existence in other parts of the township. The results of the magnetic work indicate the presence of Huronian rocks, possibly containing iron formation in the eastern and southern parts. The central and western parts are probably underlain by igneous rocks similar to those outcropping in section 23. For the distribution of the different rocks see the map, plate I.

*Magnetic Observations.*—A general discussion of magnetic observations and their significance is given in Chapter IV. There is a well defined belt of magnetic attraction crossing the south half of sections 10, 11 and 12. The attraction is mild, ranging from 1° to 10° as shown by the dip needle. This line is continuous eastward into T. 39-5 W., where it continues somewhat brokenly for many miles. Irregular mild attractions are found in section 25, also the continuation of those found to the east. Moderately strong but rather irregular attractions are found in sections 31, 32 and 33. A few negative readings were obtained in section 5, but these are thought to be due to the presence of boulders in the drift. The positive attractions are of such a nature as to indicate the presence of Huronian rocks probably containing iron formation.

*Land Classification.*—For a general discussion of the principles of land classification employed in this work the reader is referred to Chapter V. Lands along the rather definite magnetic lines in sections 10, 11 and 12 are placed in class C1. Also the lands in the magnetic area in the southwestern part of the township are placed in class C1, although considered among the least promising lands of this class. The north half of section 6 and the W.  $\frac{1}{2}$  of the N. W.  $\frac{1}{4}$  of section 5 are placed in class D because here the folded condition of the quartzite has probably caused it to cover the underlying Huronian rocks to a considerable depth, making these lands worthless for exploratory purposes. Farther away from the center of the syncline the thickness is not so great, and the presence of the quartzite is disregarded in making the classification. Undoubtedly the igneous rocks exposed near the center of section 23 extend over a considerable area which if known should be classed as D lands but the area of the exposures is so small that they have been left out of consideration in making the classification and all the remainder of the township has been placed in class C2.

*Exploration.*—The only area which appears to offer any inducements to the explorer is that part of sections 10, 11 and 12 near the magnetic line above described. The chances of finding a productive iron formation here are only fair, but the possibility cannot be eliminated until some exploratory work has been done. Much of the work done in exploration for iron ore is wasted because of failure to make intelligent use of the geologic and magnetic data to be obtained by a careful preliminary survey, and because the geologic information given by the drill is not properly used as a guide for further work. The value of careful scientific methods of exploration therefore cannot be too strongly emphasized. If exploration is contemplated in this township the discussion of this subject in Chapter VI should be carefully studied.



TOWN 39 N., R. 6 W.

Survey Made in June, 1914

Under the Direction of  
W. O. HOTCHKISS, State Geologist  
AND  
E. F. BEAN and O. W. WHEELWRIGHT,  
in charge of Field Parties  
BY  
C. A. WHITNEY, Chief of Party  
C. W. HONESS, Asst. Geologist  
T. M. LANGLEY, Asst. Geologist

**SYMBOLS AND ABBREVIATIONS.**  
The symbols and abbreviations used on this map are explained in Chapter II.

**TOWN AND RANGE LINES.**  
In constructing this map the south line of the township was laid off as a true east west line. The other boundary lines were then laid off with the lengths shown on the Land Survey plat. Some of the maps are therefore incorrect in shape but this is necessary because definite facts are lacking. The acreage of part of the lots in the north and west tier of sections is shown to give a check on the distances in these sections.

**LOCATIONS.**  
All locations are based on pacing traverses from government land corners. In many cases these were not found and it was necessary to continue the traverse several miles without a check. Locations of certain features may therefore be somewhat wrong. In such cases the feature sought may best be located by its relation to a stream, swamp, lake, or other feature shown on the map.

**PROFILES.**  
The locations of the profiles are shown on the map by dashed blue lines with black letters at the ends. Railroad profiles were furnished by the companies and show elevations of the ground rather than track in most cases; others are from road surveys by the State Highway Commission; most of them are hand level lines made by this Survey. Wherever possible the elevations above sea level are given. These elevations vary from 1050 to 1770 feet. A local datum was necessarily assumed in some cases. These cases are identifiable by the fact that the base line is always numbered 0.

**LAND CLASSIFICATION.**  
This is shown on the map by the blue letters. It is explained in the following township description and at length in chapter V.

**MAGNETIC DATA.**  
Dial compass readings are shown in blue figures. Eastward declinations are shown with a dot to the east and westward with a dot to west of the number. Dip needle readings are shown in black. All are positive except those preceded by the negative sign. All readings show deviation of needles from the normal reading of the instrument used. Normal readings are omitted from the map except at each quarter section corner. All abnormal readings are shown.

Traverses were made on lines indicated—usually the N-S section and quarter lines. Dip needle readings were taken each 50 paces, dial compass readings each 100 paces when sun permitted.

Magnetic lines are indicated by heavy black lines, solid where definite and dashed where doubtful.

**CAUTION:** Almost any kind of rock may be the cause of magnetic attraction. Do not fail to read the following description of this township, and also chapter IV., in which the magnetic attractions are discussed.

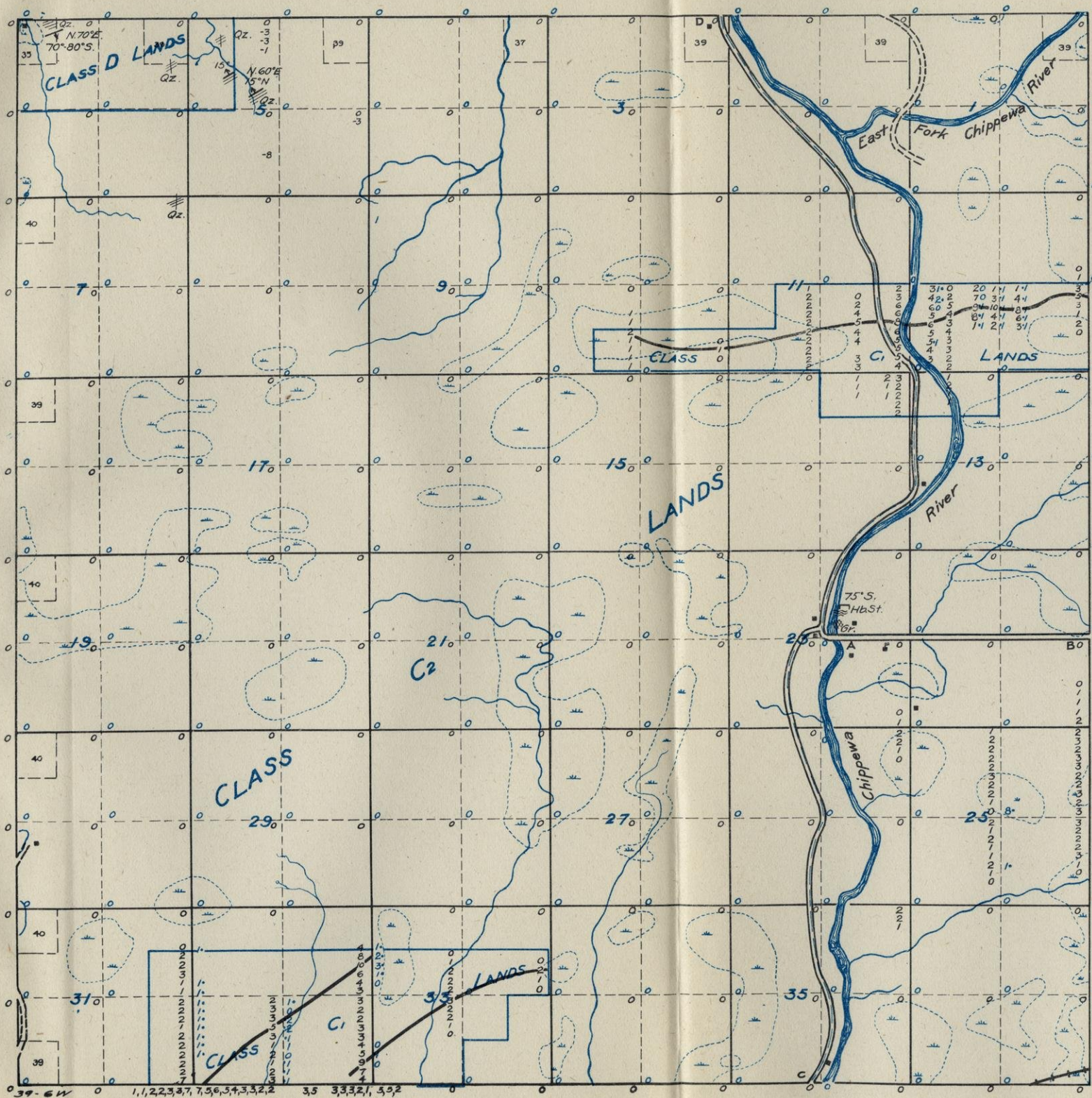

**PROFILES**

VERTICAL SCALE: 1 space = 20'  
HORIZONTAL SCALE: 3 arms as map

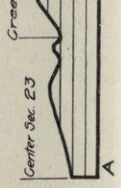
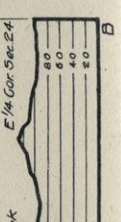
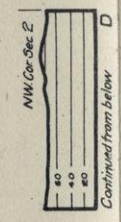

## TOWNSHIP 39 N., RANGE 7 W.

*Surface Features.*—A line drawn from the northeast corner of section 1 to the southwest corner of section 19 divides this township into two areas with distinctly different topography. That part to the southeast of this line is considerably higher than that in the northwest, and is characterized by gently rolling topography with local relief not exceeding 50 feet. Northwest of the line is a flat plain in which occur small areas of elevated rough ground exhibiting the knob and kettle type of topography. This rougher ground occurs principally to the south and southwest of Charles Lake. To the northwest of Charles Lake the ground is gently undulating but does not rise to as great an elevation as the southeastern part of the township.

The only road in the township leads from the northwest corner to Charles Lake. This is an ungraded trail, but since it passes over sandy ground is usually in fairly good condition. Much of the higher area in the southeastern part of the township is covered with a good growth of hardwood timber and logging operations are active in the area at the present time. The remainder of the township has been entirely cut over.

*Glacial Drift.*—The high area in the southeastern part of the township is covered by ground moraine. The character of the drift is distinctly different from that in the northwestern part. It is composed of silt, boulder clay, with gravel and sand in but very minor quantities. Large boulders are widely distributed and in places very numerous. The drift in the rest of the township is sandy and supports the vegetation usually associated with this type of soil. In the rougher portions boulders are found, but most of this area is an outwash plain and is entirely free from boulders. Most of sections 7, 8, 17, 18 and 19 are sufficiently rough so that they have been classed as terminal moraine. Sections 4, 5 and 6 and the north half of 7 and 8 are classed as ground moraine.

The depth of the drift in this township is uncertain but it is probably not excessive. It will undoubtedly be found to be deeper in the sandy areas than the silt area of the southeast.

*General Geology.*—There are no rock exposures and the only evidence found bearing on the character of the underlying rocks is numerous boulders of pink quartzite which are of very common occurrence in the higher part of the township. Quartzite of this type is exposed in the townships immediately adjoining on the

northeast, and this combined with the fact that numerous boulders are found here, makes it appear that this higher area is underlain by quartzite. The formation is identical with the Barron quartzite found outcropping in the townships to the southwest, but it is probably not continuous under the valley of the Couderay river. This formation may also underlie sections 5, 6 and 7 but the evidence here is not as good as for the southeastern part. Beneath this quartzite and beneath the glacial drift where the quartzite is absent, it is assumed that older rocks of both sedimentary and igneous origin exist. In most of the township this underlying rock is probably granite but in the southern part there may be Huronian rocks.

*Magnetic Observations.*—A general discussion of magnetic observations and their significance is given in Chapter IV. There is a prominent area of mild negative dip needle readings trending southwest from the N. E. corner of section 9 to the S. W. corner of section 18. Another line extends southwest from the center of section 16 to the N. E. corner of section 19. Another irregular area of negative attractions occurs in sections 31 and 32. The significance of these readings is not clear, but it is believed that they are caused by magnetic igneous rocks.

*Land Classification.*—The principles of land classification employed in this work are discussed in Chapter V. All lands in the township are placed in class C2, because evidence for more detailed classification is lacking. Such evidence as there is favors a D classification but it is not sufficient to warrant a positive statement.

*Exploration.*—Exploration is not recommended since the area presents so little evidence as to the character of the underlying formation.

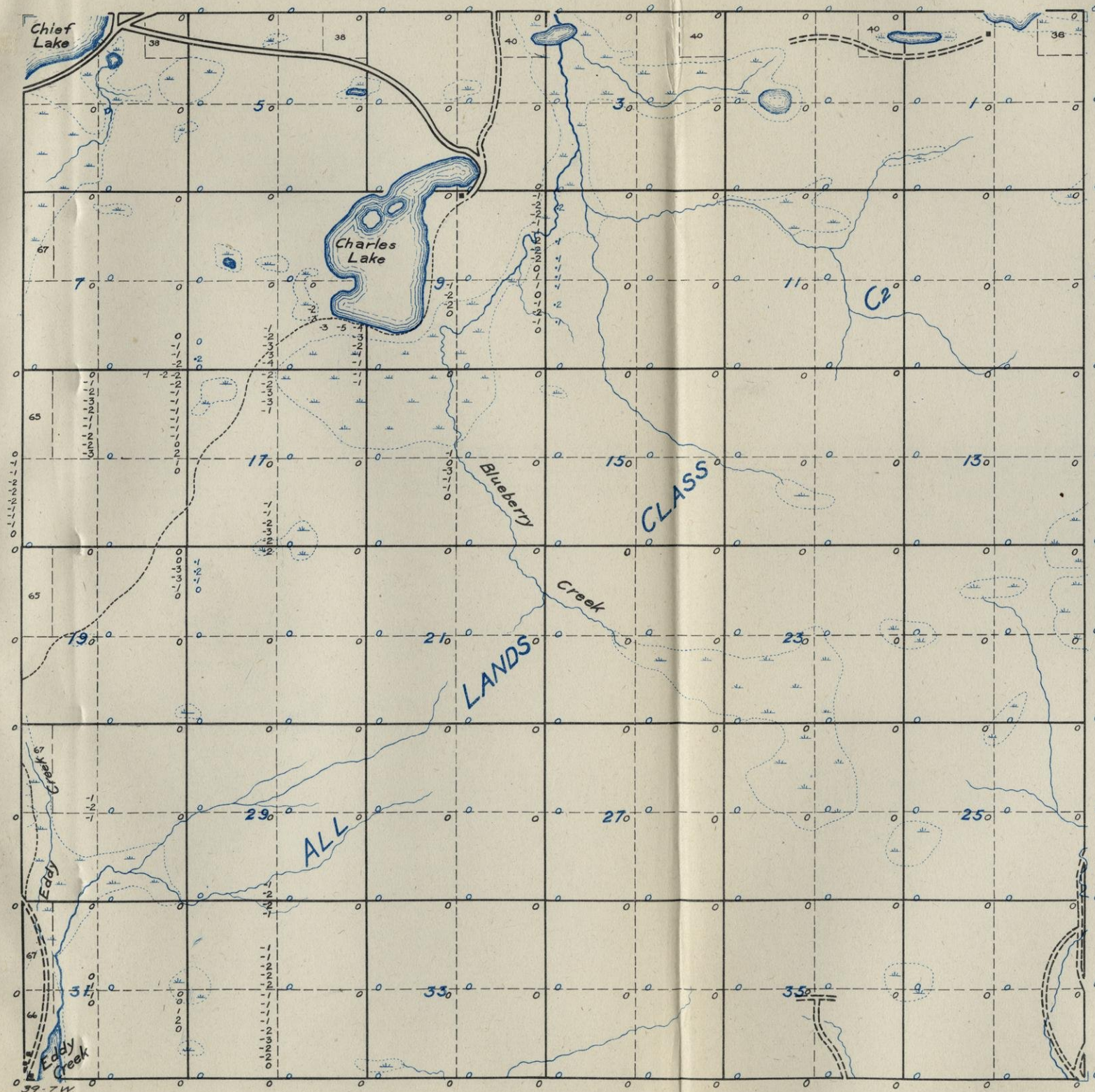

**TOWN 39 N., R. 7W.**

Survey Made in August, 1914

Under the Direction of

W. O. HOTCHKISS, State Geologist

AND

E. F. BEAN and O. W. WHEELWRIGHT,  
in charge of Field Parties

BY

T. M. BRODERICK, Chief of Party

H. N. EIDEMILLER, Asst. Geologist

F. R. PRETYMAN, Asst. Geologist

**SYMBOLS AND ABBREVIATIONS.**

The symbols and abbreviations used on this map are explained in Chapter II.

**TOWN AND RANGE LINES.**

In constructing this map the south line of the township was laid off as a true east west line. The other boundary lines were then laid off with the lengths shown on the Land Survey plat. Some of the maps are therefore incorrect in shape but this is necessary because definite facts are lacking. The acreage of part of the lots in the north and west tier of sections is shown to give a check on the distances in these sections.

**LOCATIONS.**

All locations are based on pacing traverses from government land corners. In many cases these were not found and it was necessary to continue the traverse several miles without a check. Locations of certain features may therefore be somewhat wrong. In such cases the feature sought may best be located by its relation to a stream, swamp, lake, or other feature shown on the map.

**PROFILES.**

The locations of the profiles are shown on the map by dashed blue lines with black letters at the ends. Railroad profiles were furnished by the companies and show elevations of the ground rather than track in most cases; others are from road surveys by the State Highway Commission; most of them are hand level lines made by this Survey. Wherever possible the elevations above sea level are given. These elevations vary from 1050 to 1770 feet. A local datum plane was necessarily assumed in some cases. These cases are identifiable by the fact that the base line is always numbered 0.

**LAND CLASSIFICATION.**

This is shown on the map by the blue letters. It is explained in the following township description and at length in chapter V.

**MAGNETIC DATA.**

Dial compass readings are shown in blue figures. Eastward declinations are shown with a dot to the east and westward with a dot to west of the number. Dip needle readings are shown in black. All are positive except those preceded by the negative sign. All readings show deviation of needles from the normal reading of the instrument used. Normal readings are omitted from the map except at each quarter section corner. All abnormal readings are shown.

Traverses were made on lines indicated—usually the N-S section and quarter lines. Dip needle readings were taken each 50 paces, dial compass readings each 100 paces when sun permitted.

Magnetic lines are indicated by heavy black lines, solid where definite and dashed where doubtful.

**CAUTION:** Almost any kind of rock may be the cause of magnetic attraction. Do not fail to read the following description of this township, and also chapter IV., in which the magnetic attractions are discussed.

## TOWNSHIP 39 N., RANGE 8 W.

*Surface Features.*—Most of this township is level to gently undulating. In the northwestern part there is an arm of Lac Court Oreilles. The Couderay River flows southward from this lake in a broad valley. Devils Creek flows in a marked northeast-southwest valley. The depressions occupied by Devils Lake and Bass Lake are formed by the blocking of this valley. In section 34 the bottom of this valley is 150 feet below the level of the highlands to the south.

In the accompanying profiles, A-B shows the Devils Creek valley, the undulating highlands of the central part of the township, the steep descent from the highland to the Couderay valley in section 17, and the level surface of the plain along the Couderay. Profile C-D shows that this plain has an average southward slope of about 6 feet per mile.

There are some fairly good roads in the western part of the township. Except for a belt of hardwood covering parts of sections 27, 28, 22, 23, 14, 15, 11 and 12, there is little timber left. Since this is a part of the Indian reservation, agriculture is of no importance.

*Glacial Drift.*—Outwash occurs in the northwestern part of this area and in a belt along the Couderay River. There are numerous kettles or pits in the outwash. Near the shores of Lac Court Oreilles the outwash has been dissected by streams. All the rest of the township is ground moraine which is usually gently undulating but is somewhat rougher east of Devils Lake and west of the outwash plain in sections 19, 30 and 34. This roughness is probably due to stream dissection. The glacial deposits are much silt, sand and gravel and numerous boulders in the ground moraine, and a large proportion of sand, with some silt, in the outwash.

The thickness of the drift is not definitely known. The abundance of angular quartzite fragments would indicate that on the hilltops east of the Couderay valley the drift cover is thin. Near the center of section 23 is a flat-topped area with a steep southeast facing slope which has the appearance of ledge thinly veneered with drift. The valley occupied by Lac Court Oreilles and Couderay River, and the Devils Creek, Devils Lake, Bass Lake valley are probably a pre-glacial valley filled rather deeply with glacial deposits.

*General Geology.*—No exposures of rock are found in this township but the presence of numerous angular blocks of quartzite and the topographic conditions make it possible to state with a reasonable degree of certainty that a considerable part of the township

is underlain by the Barron quartzite. The distribution of the quartzite is shown on the map, plate I. Beneath this quartzite, which is probably thin, and directly under the drift in the other parts of the township, older rocks of igneous and sedimentary origin undoubtedly exist and it is possible that iron formation is present although the information at hand favors the view that the older rocks are largely granite and gneiss.

*Magnetic Observations.*—A general discussion of magnetic observations and their significance is given in Chapter IV. A considerable part of this township shows mild and somewhat irregular negative attractions, which roughly follow lines trending about S. 60° W. as indicated on the township plat. The significance of such attractions is not well understood but it is believed that they are caused by magnetic igneous rocks.

*Land Classification.*—The principles of land classification employed in this work are discussed in Chapter V. While, as stated above, it is believed that the older rocks in this township are largely igneous, the lack of positive evidence makes it impossible to definitely classify these lands and all are placed in class C2.

*Exploration.*—Exploration in this township is not warranted on the basis of the evidence at hand.

**TOWN 39 N., R. 8W.**

Survey Made in June, 1914

Under the Direction of

W. O. HOTCHKISS, State Geologist

AND

E. F. BEAN and O. W. WHEELWRIGHT,  
in charge of Field Parties

BY

L. J. YOUNG, Chief of Party

H. N. EIDEMILLER, Asst. Geologist

F. R. PRETYMAN, Asst. Geologist

**SYMBOLS AND ABBREVIATIONS.**

The symbols and abbreviations used on this map are explained in Chapter II.

**TOWN AND RANGE LINES.**

In constructing this map the south line of the township was laid off as a true east west line. The other boundary lines were then laid off with the lengths shown on the Land Survey plat. Some of the maps are therefore incorrect in shape but this is necessary because definite facts are lacking. The acreage of part of the lots in the north and west tier of sections is shown to give a check on the distances in these sections.

**LOCATIONS.**

All locations are based on pacing traverses from government land corners. In many cases these were not found and it was necessary to continue the traverse several miles without a check. Locations of certain features may therefore be somewhat wrong. In such cases the feature sought may best be located by its relation to a stream, swamp, lake, or other feature shown on the map.

**PROFILES.**

The locations of the profiles are shown on the map by dashed blue lines with black letters at the ends. Railroad profiles were furnished by the companies and show elevations of the ground rather than track in most cases; others are from road surveys by the State Highway Commission; most of them are hand level lines made by this Survey. Wherever possible the elevations above sea level are given. These elevations vary from 1050 to 1770 feet. A local datum plane was necessarily assumed in some cases. These cases are identifiable by the fact that the base line is always numbered 0.

**LAND CLASSIFICATION.**

This is shown on the map by the blue letters. It is explained in the following township description and at length in chapter V.

**MAGNETIC DATA.**

Dial compass readings are shown in blue figures. Eastward declinations are shown with a dot to the east and westward with a dot to west of the number. Dip needle readings are shown in black. All are positive except those preceded by the negative sign. All readings show deviation of needles from the normal reading of the instrument used. Normal readings are omitted from the map except at each quarter section corner. All abnormal readings are shown.

Traverses were made on lines indicated—usually the N-S section and quarter lines. Dip needle readings were taken each 50 paces, dial compass readings each 100 paces when sun permitted.

Magnetic lines are indicated by heavy black lines, solid where definite and dashed where doubtful.

**CAUTION:** Almost any kind of rock may be the cause of magnetic attraction. Do not fail to read the following description of this township, and also chapter IV., in which the magnetic attractions are discussed.

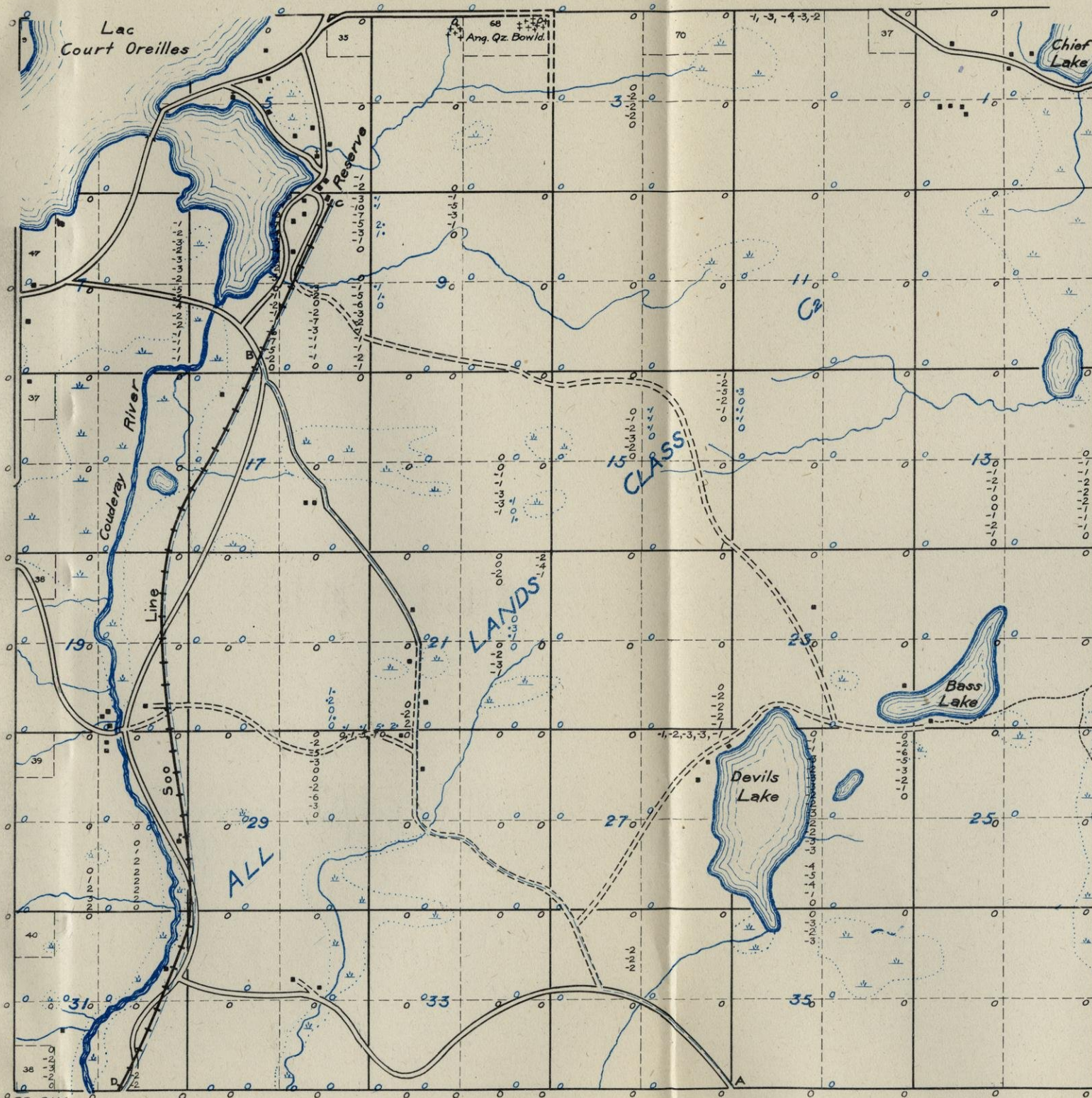

**PROFILES**

VERTICAL SCALE: 1 space = 20.  
HORIZONTAL SCALE: same as map.

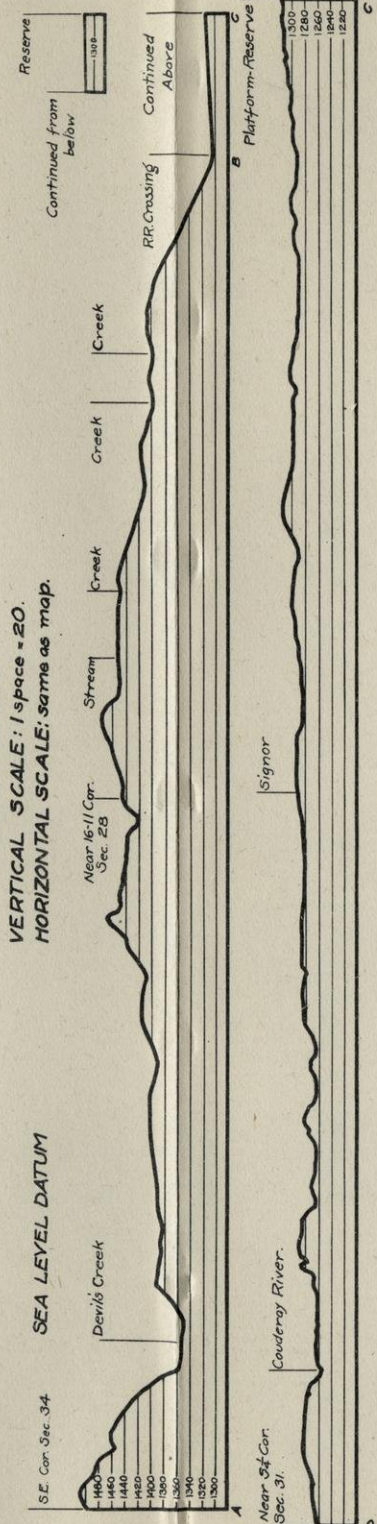

## TOWNSHIP 39 N., RANGE 9 W.

*Surface Features.*—The west third of this township has a gently undulating surface except near the lakes where the ground is somewhat rougher. An exception to this is the west half of section 6. The remainder of the township is generally rugged. Numerous lakes, many of which are of considerable size, are found and all occupy more or less marked depressions. A long prominent valley extends through the centers of sections 23, 26 and 35. It is not occupied by a stream at the present time and appears to have been a preglacial channel which probably extended down into the channel now occupied by Lake Chetac in the township to the south. The single profile of the Soo railroad shows the generally level condition of the surface in the southwestern part of the township.

The roads are generally good and in the northwestern part of the township have been placed on property lines and are well graded. Those in the eastern part are in sandy country so that they are passable at nearly all times. Some timber remains in sections 25, 26 and 36, but nearly all of the remainder of the township has been cut. Settlers are numerous northeast of the village of Stone Lake.

*Glacial Drift.*—The western third and most of the northern third of the township are covered with outwash deposits, but in the northern row of sections the ground moraine deposits beneath are not completely covered. The material composing the drift in these areas is silt and sand with gravel in places. In the south central part of the township is a rugged terminal moraine except in section 33, where a small outwash plain has been developed. All of the area east of the large valley above mentioned is high undulating ground moraine. The elevation of this part of the township is probably due to the presence of quartzite underlying the glacial drift. The ground and terminal moraine deposits are characterized by their sandy nature, but boulders are more or less numerous wherever this type of deposit is found.

It is believed that the thickness of the drift will prove to be great in all parts of the township, except in the southeastern quarter over the quartzite.

*General Geology.*—No exposures of rock were found, but judging from topographic conditions and information obtained in the townships to the east and southeast, it is believed that all of sections 24, 25 and 36 and parts of sections 23, 26 and 35 are underlain by the



Barron quartzite. It is possible also that much of the south central part of this township may contain this same type of rock, but the evidence here is not as strong as for the area in the eastern part. Sandstone probably underlies the remainder of the township. No information was obtained as to the character of the formation underlying the sandstone and quartzite. It is believed that rocks of Huronian age may occur here and the presence of iron formation is considered as a possibility.

*Magnetic Observations.*—No abnormal attraction was found in this township.

*Land Classification.*—The principles of land classification employed in this work are discussed in Chapter V. All lands are placed in class C2 for lack of information upon which to base a more definite classification.

*Exploration.*—There is no evidence at hand on which exploration can be recommended.

TOWN 39 N., R. 9W.

Survey Made in July, 1914

Under the Direction of  
W. O. HOTCHKISS, State Geologist  
AND  
E. F. BEAN and O. W. WHEELWRIGHT,  
in charge of Field Parties  
BY

T. M. BRODERICK, Chief of Party  
H. D. WAKEFIELD, Asst. Geologist  
R. S. TARR, Asst. Geologist

**SYMBOLS AND ABBREVIATIONS.**  
The symbols and abbreviations used on this map are explained in Chapter II.

**TOWN AND RANGE LINES.**  
In constructing this map the south line of the township was laid off as a true east west line. The other boundary lines were then laid off with the lengths shown on the Land Survey plat. Some of the maps are therefore incorrect in shape but this is necessary because definite facts are lacking. The acreage of part of the lots in the north and west tier of sections is shown to give a check on the distances in these sections.

**LOCATIONS.**  
All locations are based on pacing traverses from government land corners. In many cases these were not found and it was necessary to continue the traverse several miles without a check. Locations of certain features may therefore be somewhat wrong. In such cases the feature sought may best be located by its relation to a stream, swamp, lake, or other feature shown on the map.

**PROFILES.**  
The locations of the profiles are shown on the map by dashed blue lines with black letters at the ends. Railroad profiles were furnished by the companies and show elevations of the ground rather than track in most cases; others are from road surveys by the State Highway Commission; most of them are hand level lines made by this Survey. Wherever possible the elevations above sea level are given. These elevations vary from 1050 to 1770 feet. A local datum plane was necessarily assumed in some cases. These cases are identifiable by the fact that the base line is always numbered 0.

**LAND CLASSIFICATION.**  
This is shown on the map by the blue letters. It is explained in the following township description and at length in chapter V.

**MAGNETIC DATA.**  
Dial compass readings are shown in blue figures. Eastward declinations are shown with a dot to the east and westward with a dot to west of the number. Dip needle readings are shown in black. All are positive except those preceded by the negative sign. All readings show deviation of needles from the normal reading of the instrument used. Normal readings are omitted from the map except at each quarter section corner. All abnormal readings are shown.

Traverses were made on lines indicated—usually the N-S section and quarter lines. Dip needle readings were taken each 50 paces, dial compass readings each 100 paces when sun permitted.

Magnetic lines are indicated by heavy black lines, solid where definite and dashed where doubtful.

**CAUTION:** Almost any kind of rock may be the cause of magnetic attraction. Do not fail to read the following description of this township, and also chapter IV., in which the magnetic attractions are discussed.

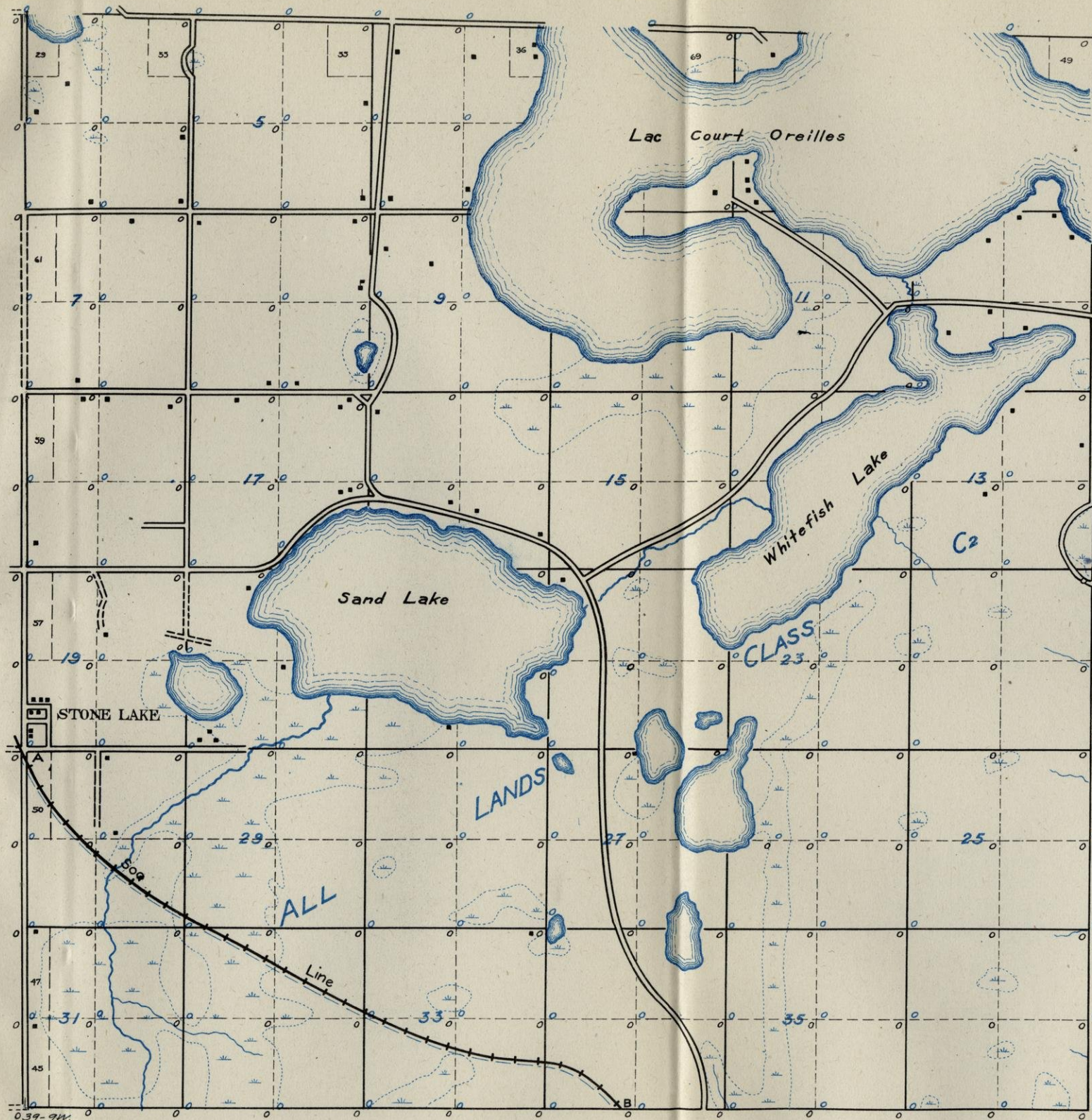

PROFILE  
VERTICAL SCALE: 1 space = 20'  
HORIZONTAL SCALE: same as map

SEA LEVEL DATUM

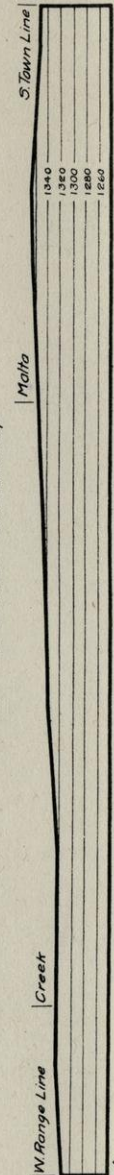

## TOWNSHIP 39 N., RANGE 10 W.

*Surface Features.*—There are two areas of roughly undulating topography. One is in sections 1, 2 and 3; and the other is in an irregular area extending through section 4 to the middle of 21, eastward to the middle of 13, and then south to the northeast corner of 34. The southwestern part is a gently undulating plain. The remainder is a pitted plain with numerous large swamps. The accompanying profile C-D does not show the character of the northeastern part of the township, as the railroad has secured an easy grade by following a valley.

There is a good road on the east range line and another extending from the town of Stone Lake to the settled area in the western part of the township. Good farms are found in the western and eastern parts of the township. Very little timber is left in the area.

*Glacial Drift.*—In the northeastern part of the township there is an area of terminal moraine with characteristic knob and kettle topography. The other roughly undulating area is terminal moraine made up of pronounced ridges trending north-south and east-west. In the southwestern part is an area of gently undulating ground moraine. The remainder of the township is an outwash plain. South of Stone Lake and in sections 21, 22, 27 and 28 this plain is pitted, while in the northwest it is very level. There are numerous swamps and small lakes everywhere in the outwash. The outwash deposits are chiefly sand with some gravel and silt; silt with some sand, gravel and boulders in the terminal moraine.

Ledge does not outcrop, nor is it reported in wells. The following well records indicate a thick covering of drift in the eastern part of the township: 141 feet in the N. E.  $\frac{1}{4}$  of N. W.  $\frac{1}{4}$ , section 26; 85 feet in the S. E.  $\frac{1}{4}$  of S. W.  $\frac{1}{4}$  of section 35; 200 feet in the S. E.  $\frac{1}{4}$  S. W.  $\frac{1}{4}$  of section 14. That the surface is deep in the western part of the township is indicated by the fact that wells in T. 39-11 W., average 100 feet in depth and do not reach ledge.

*General Geology.*—There are no exposures of rock in this township and no wells reach the ledge. There is some reason for believing that sandstone will be found overlying the older rocks, but this is not definitely known.

*Magnetic Observations.*—No abnormal attractions were found in this township.

*Land Classification.*—The principles of land classification employed in this work are discussed in Chapter V. For lack of information regarding the character of the underlying rocks, all lands are placed in class C2.

*Exploration.*—Exploration in this township cannot be recommended until more information on the geology is available. The occurrence of iron formation is recognized as a possibility but it would be a waste of money to attempt to find it with nothing to indicate its location.

TOWN 39 N., R. 10 W.

Survey Made in July, 1914

Under the Direction of  
W. O. HOTCHKISS, State Geologist

AND  
E. F. BEAN and O. W. WHEELWRIGHT,  
in charge of Field Parties

BY

T. M. BRODERICK, Chief of Party

H. D. WAKEFIELD, Asst. Geologist

R. S. TARR, Asst. Geologist

**SYMBOLS AND ABBREVIATIONS.**  
The symbols and abbreviations used on this map are explained in Chapter II.

**TOWN AND RANGE LINES.**  
In constructing this map the south line of the township was laid off as a true east west line. The other boundary lines were then laid off with the lengths shown on the Land Survey plat. Some of the maps are therefore incorrect in shape but this is necessary because definite facts are lacking. The acreage of part of the lots in the north and west tier of sections is shown to give a check on the distances in these sections.

**LOCATIONS.**  
All locations are based on pacing traverses from government land corners. In many cases these were not found and it was necessary to continue the traverse several miles without a check. Locations of certain features may therefore be somewhat wrong. In such cases the feature sought may best be located by its relation to a stream, swamp, lake, or other feature shown on the map.

**PROFILES.**  
The locations of the profiles are shown on the map by dashed blue lines with black letters at the ends. Railroad profiles were furnished by the companies and show elevations of the ground rather than track in most cases; others are from road surveys by the State Highway Commission; most of them are hand level lines made by this Survey. Wherever possible the elevations above sea level are given. These elevations vary from 1050 to 1770 feet. A local datum plane was necessarily assumed in some cases. These cases are identifiable by the fact that the base line is always numbered 0.

**LAND CLASSIFICATION.**  
This is shown on the map by the blue letters. It is explained in the following township description and at length in chapter V.

**MAGNETIC DATA.**  
Dial compass readings are shown in blue figures. Eastward declinations are shown with a dot to the east and westward with a dot to west of the number. Dip needle readings are shown in black. All are positive except those preceded by the negative sign. All readings show deviation of needles from the normal reading of the instrument used. Normal readings are omitted from the map except at each quarter section corner. All abnormal readings are shown.

Traverses were made on lines indicated—usually the N-S section and quarter lines. Dip needle readings were taken each 50 paces, dial compass readings each 100 paces when sun permitted.

Magnetic lines are indicated by heavy black lines, solid where definite and dashed where doubtful.

**CAUTION:** Almost any kind of rock may be the cause of magnetic attraction. Do not fail to read the following description of this township, and also chapter IV., in which the magnetic attractions are discussed.

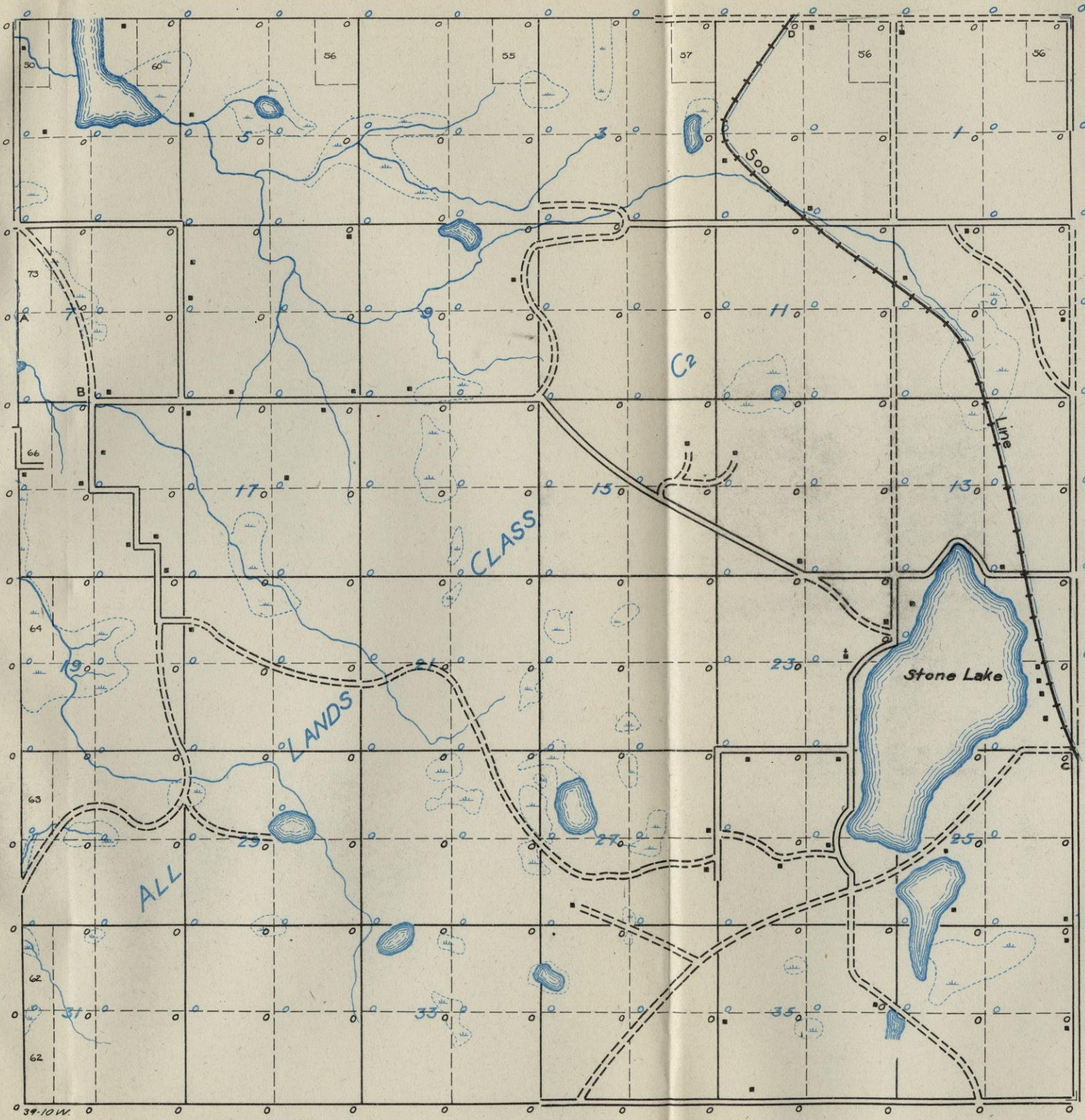

PROFILES

VERTICAL SCALE: 1 space = 20'  
HORIZONTAL SCALE: same as map

SEA LEVEL DATUM

LOCAL DATUM

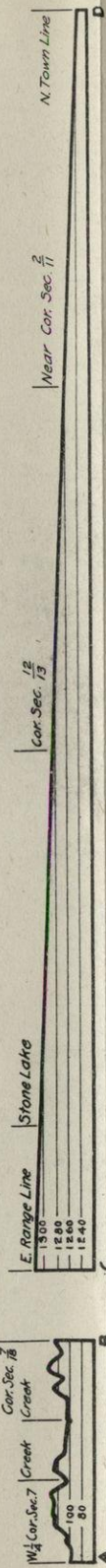

## TOWNSHIP 39 N., RANGE 11 W.

*Surface Features.*—Potato Creek flows through a plain in the south central part of the township. Mackay Creek in the northeast and Veazie Creek in the northwest drain similar plains. The remainder of the township is in general higher than the plain and the topography varies from nearly level to roughly undulating. As shown in profile A-B the highland in the southeast has a level to gently undulating surface. From the northern edge of this highland (profile B-C) there is a descent of nearly 170 feet to the plain at the north. In the northern part of the township (profile E-F) the highland rises to a height of 140 feet above the valley of Potato Creek.

The roads of this township are in general quite good though in the more level areas the sand is often deep and in the rougher country the grades are heavy. Except for small areas all the timber of value has been cut. The soil is productive and the township is well settled.

*Glacial Drift.*—In the northwestern and northeastern parts of the township are areas of outwash which connect with the plain of the Namakagon River in T. 40-11 W. There is a belt of outwash along Potato Creek and around Peterson Lake. In the east central part of the township is an area of very swampy ground moraine. In the southwestern part is an area of gently undulating ground moraine, nearly free from boulders. The remainder of the township is terminal moraine. In the southeast the terminal moraine has a steep slope to the north and a rather level to gently undulating surface which extends southward into T. 38-11 W. The terminal moraine in the northern part is not quite so high as that in the south. The western part has rough topography with lakes and swamps occupying the depressions. The eastern part is of lower relief.

The glacial deposits are sand, gravel, some silt and boulders in the terminal moraine; sand, some silt and gravel in the ground moraine; much sand with gravel and some silt in the outwash.

Although rock is exposed west of the quarter corner of sections 1 and 12, it is not believed that the surface is shallow over the surrounding area. Well records indicate that over the greater part of the township the drift cover averages over 100 feet in thickness.

*General Geology.*—Rocks are exposed at but one point in this township. A high hill on the section line between 1 and 12 about

200 paces west of the quarter post shows a number of exposures of quartzite and conglomerate. On the northwest side of this hill quartzite is exposed in several places well up toward the crest. The rock consists of sand grains, cemented with silica, has a pink color and is massive, the bedding being very indistinct. On the north side of the hill where bedding is best shown a strike of N. 85° E. and a dip of 15° to the north was observed. At a point on the east side the strike is N. 45° E. and the dip 45° to the northwest. On the south side of the hill along a steep cliff conglomerate is exposed. This conglomerate appears to be at least 50 feet thick. It strikes N. 40° E. and dips about 60° to the west. The pebbles are very well rounded and vary from 1 to 8 inches in diameter, averaging 4 inches. Nearly all of them are pink quartzite varying from a very uniform salmon pink to striped pink and white in color. A very few quartz pebbles are found in the conglomerate. Both the pink and striped quartzite found in these pebbles resemble very closely the Barron quartzite found some distance to the southeast. The matrix surrounding the pebbles is composed of a fine quartz sand having a somewhat more yellowish color than the pebbles. This conglomerate is beneath the quartzite on the opposite side of the hill, and judging from the character of the pebbles is younger than the Barron quartzite. It appears that there must be two formations of quartzite in this vicinity, of distinctly different ages. Undoubtedly this hill is merely a remnant of a more extensive formation. There is no information as to the character of the underlying rock in other parts of the township but they are believed to be older rocks of igneous and sedimentary origin in which an iron formation is a possibility. There is good reason to believe that sandstone will be found overlying the older rocks throughout the township.

*Magnetic Observations.*—No abnormal magnetic attraction was found in this township.

*Land Classification.*—The principles of land classification employed in this work are discussed in chapter V. All lands in this township are placed in class C2, since iron formation may occur. The presence of the quartzite in sections 1 and 2 is not taken into consideration since it covers but a very small part of two forty-acre tracts and there is much doubt of its being more extensive underneath the drift.

*Exploration.*—Exploration in this township cannot be recommended on the evidence at hand.

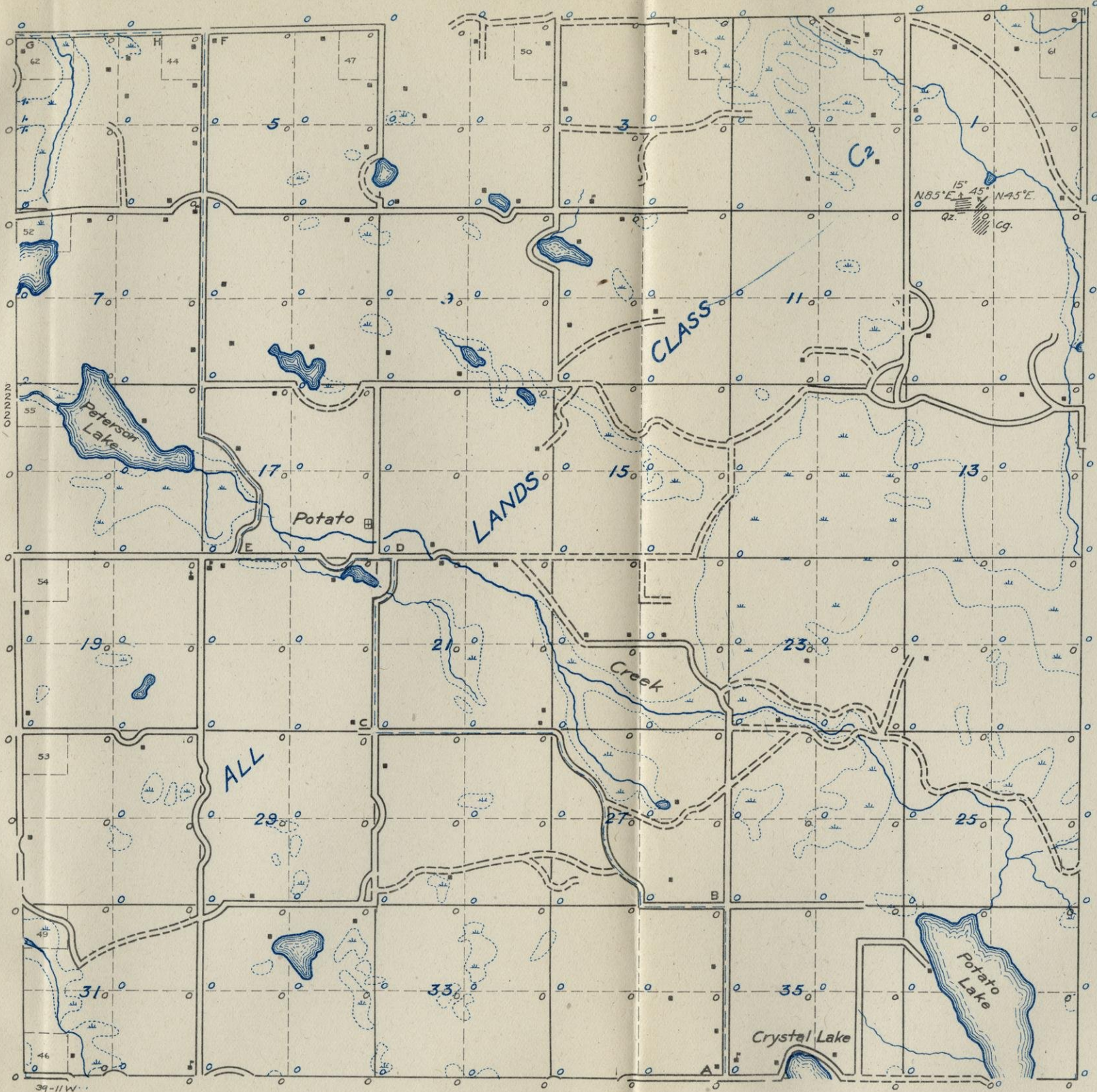

**PROFILES**  
 VERTICAL SCALE: 1 space = 20'  
 HORIZONTAL SCALE: same as map  
 SEA LEVEL DATUM

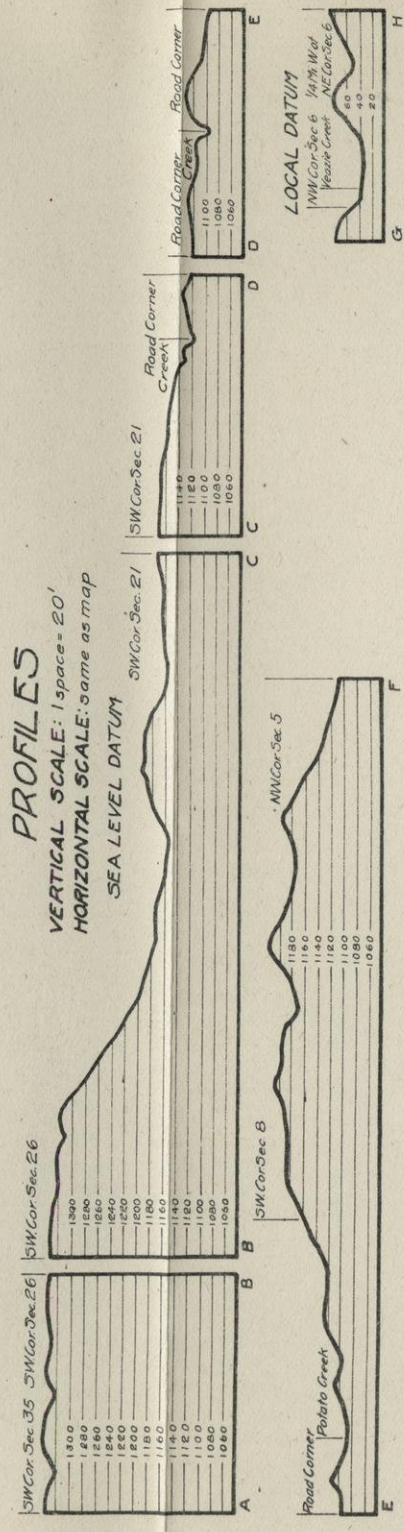

**TOWN 39 N., R. 11 W.**

Survey Made in July, 1914.

Under the Direction of  
**W. O. HOTCHKISS**, State Geologist  
 AND  
**E. F. BEAN** and **O. W. WHEELWRIGHT**,  
 in charge of Field Parties  
 BY  
**W. L. DOBIE**, Chief of Party  
**O. W. POTTER**, Asst. Geologist  
**D. G. THOMPSON**, Asst. Geologist

**SYMBOLS AND ABBREVIATIONS.**  
 The symbols and abbreviations used on this map are explained in Chapter II.

**TOWN AND RANGE LINES.**  
 In constructing this map the south line of the township was laid off as a true east west line. The other boundary lines were then laid off with the lengths shown on the Land Survey plat. Some of the maps are therefore incorrect in shape but this is necessary because definite facts are lacking. The acreage of part of the lots in the north and west tier of sections is shown to give a check on the distances in these sections.

**LOCATIONS.**  
 All locations are based on pacing traverses from government land corners. In many cases these were not found and it was necessary to continue the traverse several miles without a check. Locations of certain features may therefore be somewhat wrong. In such cases the feature sought may best be located by its relation to a stream, swamp, lake, or other feature shown on the map.

**PROFILES.**  
 The locations of the profiles are shown on the map by dashed blue lines with black letters at the ends. Railroad profiles were furnished by the companies and show elevations of the ground rather than track in most cases; others are from road surveys by the State Highway Commission: most of them are hand level lines made by this Survey. Wherever possible the elevations above sea level are given. These elevations vary from 1050 to 1770 feet. A local datum plane was necessarily assumed in some cases. These cases are identifiable by the fact that the base line is always numbered 0.

**LAND CLASSIFICATION.**  
 This is shown on the map by the blue letters. It is explained in the following township description and at length in chapter V.

**MAGNETIC DATA.**  
 Dial compass readings are shown in blue figures. Eastward declinations are shown with a dot to the east and westward with a dot to west of the number. Dip needle readings are shown in black. All are positive except those preceded by the negative sign. All readings show deviation of needles from the normal reading of the instrument used. Normal readings are omitted from the map except at each quarter section corner. All abnormal readings are shown.

Traverses were made on lines indicated—usually the N-S section and quarter lines. Dip needle readings were taken each 50 paces, dial compass readings each 100 paces when sun permitted.

Magnetic lines are indicated by heavy black lines, solid where definite and dashed where doubtful.

**CAUTION:** Almost any kind of rock may be the cause of magnetic attraction. Do not fail to read the following description of this township, and also chapter IV., in which the magnetic attractions are discussed.



## TOWNSHIP 39 N., RANGE 12 W.

*Surface Features.*—A belt of roughly undulating topography extends from the northeast corner of the township through the center to the west line of section 19. The southeastern part of the township is roughly undulating. The remainder is level to gently undulating. Large swamps are found in the northwestern part.

The profiles give an excellent idea of the irregularities of the topography. Profile B-D shows a rise of 90 feet from the plain in the southern part of section 14 to the high rough country in the northern part of that section, and a descent of 100 feet to the valley of Potato Creek. Profile E-C shows that this highland rises about the same distance above the plain to the west. The valley of Potato Creek between sections 2 and 3 is well shown on profile H-K.

Except for the fact that they are very sandy in some places, the roads of the township are good. The main travelled road is the one parallel to the Omaha railway. There are a number of good farms in the more level parts and the University of Wisconsin maintains an experimental farm in section 32. The timber is practically all gone.

*Glacial Drift.*—There is a large area of ground moraine in the northwestern part of the township. The greater part of this area is covered by tamarack swamp. Outside the swamp the land is slightly higher and gently undulating. There are several areas of terminal moraine. The largest enters at the northeastern corner of the township and trends southwest through the center. The northeastern part of this is very rough, with steep-sided knobs and kettles. The hills rise to elevations of from 50 to 100 feet above the outwash area to the north and south. There are smaller areas of terminal moraine in sections 30 and 5 and in the southeastern part of the township. The remainder of the township is outwash. East of Spooner Lake there are numerous depressions in the outwash occupied by swamps and small lakes. The outwash in the north central part and that in the southwestern part is pitted and dissected by streams.

The glacial deposits are largely sand with a small amount of silt in the outwash. The terminal and group moraine are chiefly sand and gravel with silt. Boulders are numerous in the ground moraine.

The drift is known to be thin in sections 6 and 7 near the outcrops. Ledge is reported at a depth of 34 feet in a well southwest of the

north quarter post of section 1, in the township south. Near the northeast corner of section 25 a depth of over 100 feet is reported without reaching ledge.

*General Geology.*—The only exposures of rock are in sections 6 and 7 where some old test pits, a cellar, and a few wells have penetrated a pink quartzite. The rock consists of fine quartz sand grains very thoroughly cemented with silica and has a color varying from light pink to a deep brick red. This rock is in all probability identical with the Barron quartzite found some 15 miles to the southeast. In one of the pits occurring near the southeastern corner of section 6 is a suggestion of bedding which indicates a strike of N. 70° W. and a dip of 50° N. This is not conclusive, however. Angular blocks found on the surface indicate that sections 6 and 7 are underlain by this rock. The results of magnetic work indicate that rocks of the Keweenawan trap series extend into the northwestern part. Just how extensive they are is not known.

Definite information as to the character of the underlying rock in the remainder of the township is lacking. There is little doubt that there is a cover of sandstone over the older rocks. A shallow well in the northeast corner of T. 38-12 W. struck this rock and it is also known to occur farther north at Hayward.

*Magnetic Observations.*—A general discussion of magnetic observations and their significance is given in chapter IV. Moderately strong dip needle attractions were obtained in the northwest corner of the township and abnormal dial readings were obtained over a somewhat larger area. The dial readings were nearly always to the west and show but little variation but become milder as the distance from the area of the dip needle attractions becomes greater. The limits of the dip needle attractions are thought to show the limits of a magnetic formation. These attractions continue in the township to the west, and this appears to be merely a tongue of the magnetic rock extending over into T. 39-12 W. The nature of the rock causing these attractions is not certainly known, but it is believed on very good evidence that it is the Keweenawan trap. Some rather irregular attraction was obtained in the vicinity of Spooner, but it is very local and is not considered as indicating an extension of the trap formation to that vicinity.

*Land Classification.*—The principles of land classification employed in this work are discussed in Chapter V. Lands in the magnetic area in the northwestern part are placed in class D, for the reasons

TOWN 39 N., R. 12 W.

Survey Made in June, 1914

Under the Direction of  
W. O. HOTCHKISS, State Geologist  
AND  
E. F. BEAN and O. W. WHEELWRIGHT,  
in charge of Field Parties

BY  
W. L. DOBIE, Chief of Party  
O. W. POTTER, Asst. Geologist  
D. G. THOMPSON, Asst. Geologist

SYMBOLS AND ABBREVIATIONS.

The symbols and abbreviations used on this map are explained in Chapter II.

TOWN AND RANGE LINES.

In constructing this map the south line of the township was laid off as a true east west line. The other boundary lines were then laid off with the lengths shown on the Land Survey plat. Some of the maps are therefore incorrect in shape but this is necessary because definite facts are lacking. The acreage of part of the lots in the north and west tier of sections is shown to give a check on the distances in these sections.

LOCATIONS.

All locations are based on pacing traverses from government land corners. In many cases these were not found and it was necessary to continue the traverse several miles without a check. Locations of certain features may therefore be somewhat wrong. In such cases the feature sought may best be located by its relation to a stream, swamp, lake, or other feature shown on the map.

PROFILES.

The locations of the profiles are shown on the map by dashed blue lines with black letters at the ends. Railroad profiles were furnished by the companies and show elevations of the ground rather than track in most cases; others are from road surveys by the State Highway Commission; most of them are hand level lines made by this Survey. Wherever possible the elevations above sea level are given. These elevations vary from 1050 to 1770 feet. A local datum plane was necessarily assumed in some cases. These cases are identifiable by the fact that the base line is always numbered 0.

LAND CLASSIFICATION.

This is shown on the map by the blue letters. It is explained in the following township description and at length in chapter V.

MAGNETIC DATA.

Dial compass readings are shown in blue figures. Eastward declinations are shown with a dot to the east and westward with a dot to west of the number. Dip needle readings are shown in black. All are positive except those preceded by the negative sign. All readings show deviation of needles from the normal reading of the instrument used. Normal readings are omitted from the map except at each quarter section corner. All abnormal readings are shown.

Traverses were made on lines indicated—usually the N-S section and quarter lines. Dip needle readings were taken each 50 paces, dial compass readings each 100 paces when permitted.

Magnetic lines are indicated by heavy black lines, solid where definite and dashed where doubtful.

CAUTION: Almost any kind of rock may be the cause of magnetic attraction. Do not fail to read the following description of this township, and also chapter IV., in which the magnetic attractions are discussed.

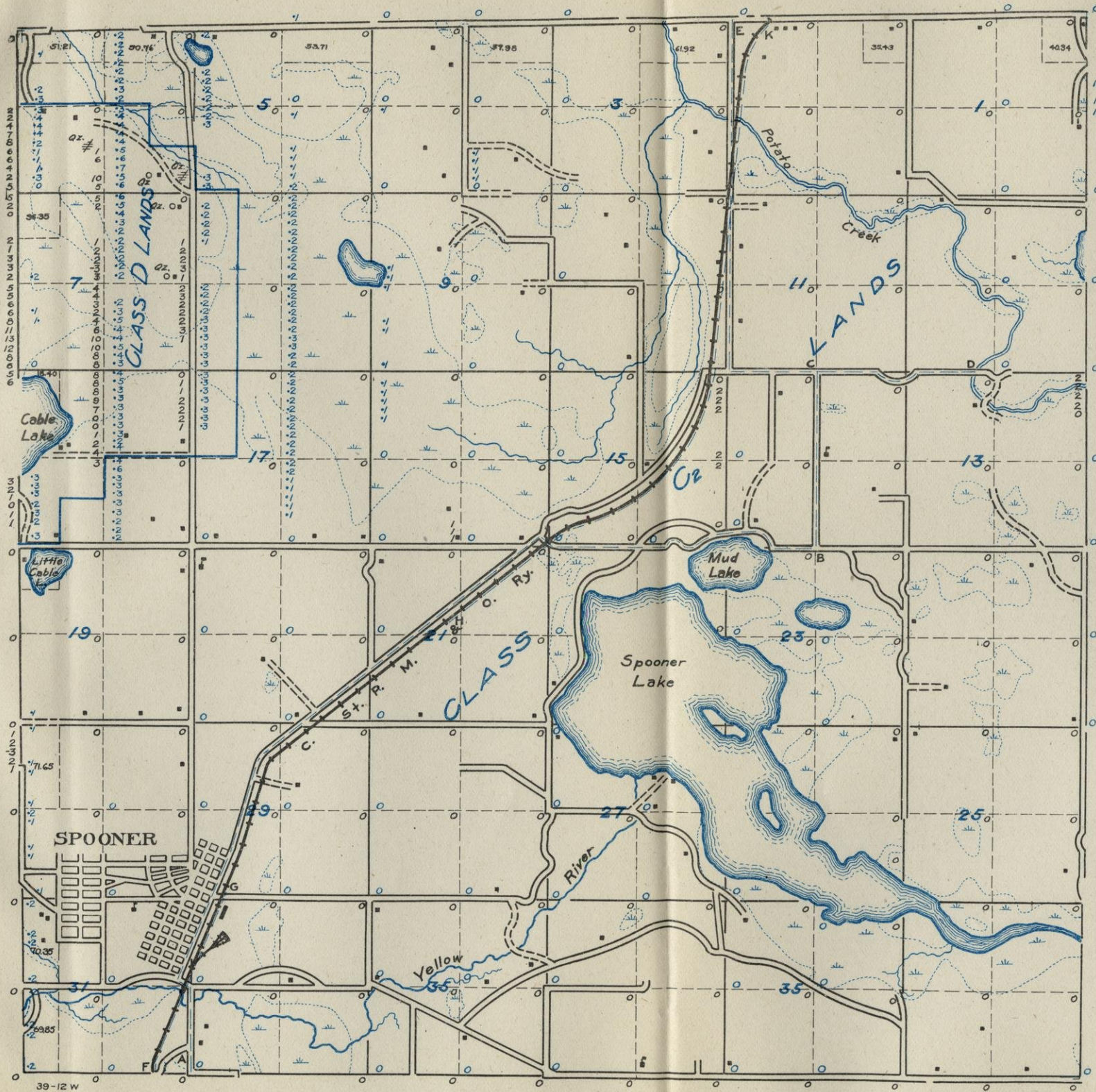

PROFILES

VERTICAL SCALE: 1 space = 20'  
HORIZONTAL SCALE: same as map.

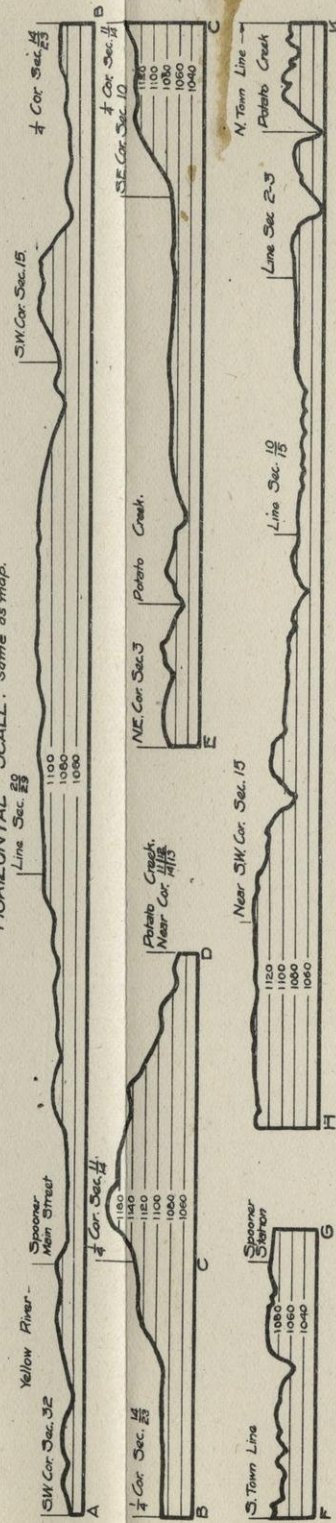

stated above. All other lands in the township are placed in class C2 since the presence of iron formation is a possibility.

*Recommendations for Exploration.*—Exploration for iron ore in this township cannot be recommended on the basis of present information.

## TOWNSHIP 39 N., RANGE 13 W.

*Surface Features.*—There are two areas of rough topography in this township. One extends from sections 10 and 11 to 28 and 29. The other is in sections 24 and 25. The first rises 100 to 140 feet above the more level surroundings, and the second rises 180 feet above the plain to the west. The remainder of the township is level to gently undulating. There are numerous large swamps in the eastern part of the township and considerable stream dissection near the Yellow River. In the lower areas there are numerous lakes.

Profile A-B shows the rise of 100 feet from the plain in section 23 to the summit of the hill near the northwest corner of section 28 and the descent of nearly 140 feet to the northern plain. Profile C-D shows the northward descent of nearly 120 feet from the highland in section 10 to the plain in section 3. Profile G-H shows a rise of over 100 feet from the southwest corner of section 24, to the southeast corner.

Roads in the plain are very sandy. In the higher and rougher land the hills are steep, making travel somewhat difficult. All the good timber has been cut. There are some good farms in the area.

*Glacial Drift.*—The area of rough topography in the central part of the township is a terminal moraine. In sections 24, 25 and 31 are smaller areas of terminal moraine. In the northwestern part of the township is an area of undulating ground moraine in which the bowlders are small and few in number. There are several small lakes and swamps. East of the terminal is undulating ground moraine with numerous bowlders and large areas of swamp. Outwash is found in sections 1, 2 and 3, and along the Yellow River in the south part of the township. It is dissected by streams in the southeast, but quite level elsewhere. The glacial deposits are sand some gravel, silt and bowlders in the terminal moraine; sand with some gravel and bowlders in the ground moraine; and sand with some silt in the outwash.

The average thickness of the drift in this township is great. One well west of the southeast corner of section 28 shows ledge at a depth of 115 feet. No other wells reach ledge but depths of from 100 to 200 feet are common. It is probable, therefore, that the average drift cover is over 100 feet in thickness.

*General Geology.*—No outcrops were found in this township and the rocks are deeply buried. While quartzite is found very close to the surface in the township adjoining on the northeast, the wells

TOWN 39 N., R. 13W.

Survey Made in August, 1914

Under the Direction of

W. O. HOTCHKISS, State Geologist

AND

E. F. BEAN and O. W. WHEELWRIGHT,  
in charge of Field Parties

BY

W. L. DOBIE, Chief of Party  
O. W. POTTER, Asst. Geologist  
D. G. THOMPSON, Asst. Geologist  
HOWARD QUINLAN, Asst. Geologist

**SYMBOLS AND ABBREVIATIONS.**

The symbols and abbreviations used on this map are explained in Chapter II.

**TOWN AND RANGE LINES.**

In constructing this map the south line of the township was laid off as a true east west line. The other boundary lines were then laid off with the lengths shown on the Land Survey plat. Some of the maps are therefore incorrect in shape but this is necessary because definite facts are lacking. The acreage of part of the lots in the north and west tier of sections is shown to give a check on the distances in these sections.

**LOCATIONS.**

All locations are based on pacing traverses from government land corners. In many cases these were not found and it was necessary to continue the traverse several miles without a check. Locations of certain features may therefore be somewhat wrong. In such cases the feature sought may best be located by its relation to a stream, swamp, lake, or other feature shown on the map.

**PROFILES.**

The locations of the profiles are shown on the map by dashed blue lines with black letters at the ends. Railroad profiles were furnished by the companies and show elevations of the ground rather than track in most cases; others are from road surveys by the State Highway Commission; most of them are hand level lines made by this Survey. Wherever possible the elevations above sea level are given. These elevations vary from 1050 to 1770 feet. A local datum plane was necessarily assumed in some cases. These cases are identifiable by the fact that the base line is always numbered 0.

**LAND CLASSIFICATION.**

This is shown on the map by the blue letters. It is explained in the following township description and at length in chapter V.

**MAGNETIC DATA.**

Dial compass readings are shown in blue figures. Eastward declinations are shown with a dot to the east and westward with a dot to west of the number. Dip needle readings are shown in black. All are positive except those preceded by the negative sign. All readings show deviation of needles from the normal reading of the instrument used. Normal readings are omitted from the map except at each quarter section corner. All abnormal readings are shown.

Traverses were made on lines indicated—usually the N-S section and quarter lines. Dip needle readings were taken each 50 paces, dial compass readings each 100 paces when sun permitted.

Magnetic lines are indicated by heavy black lines, solid where definite and dashed where doubtful.

**CAUTION:** Almost any kind of rock may be the cause of magnetic attraction. Do not fail to read the following description of this township, and also chapter IV., in which the magnetic attractions are discussed.

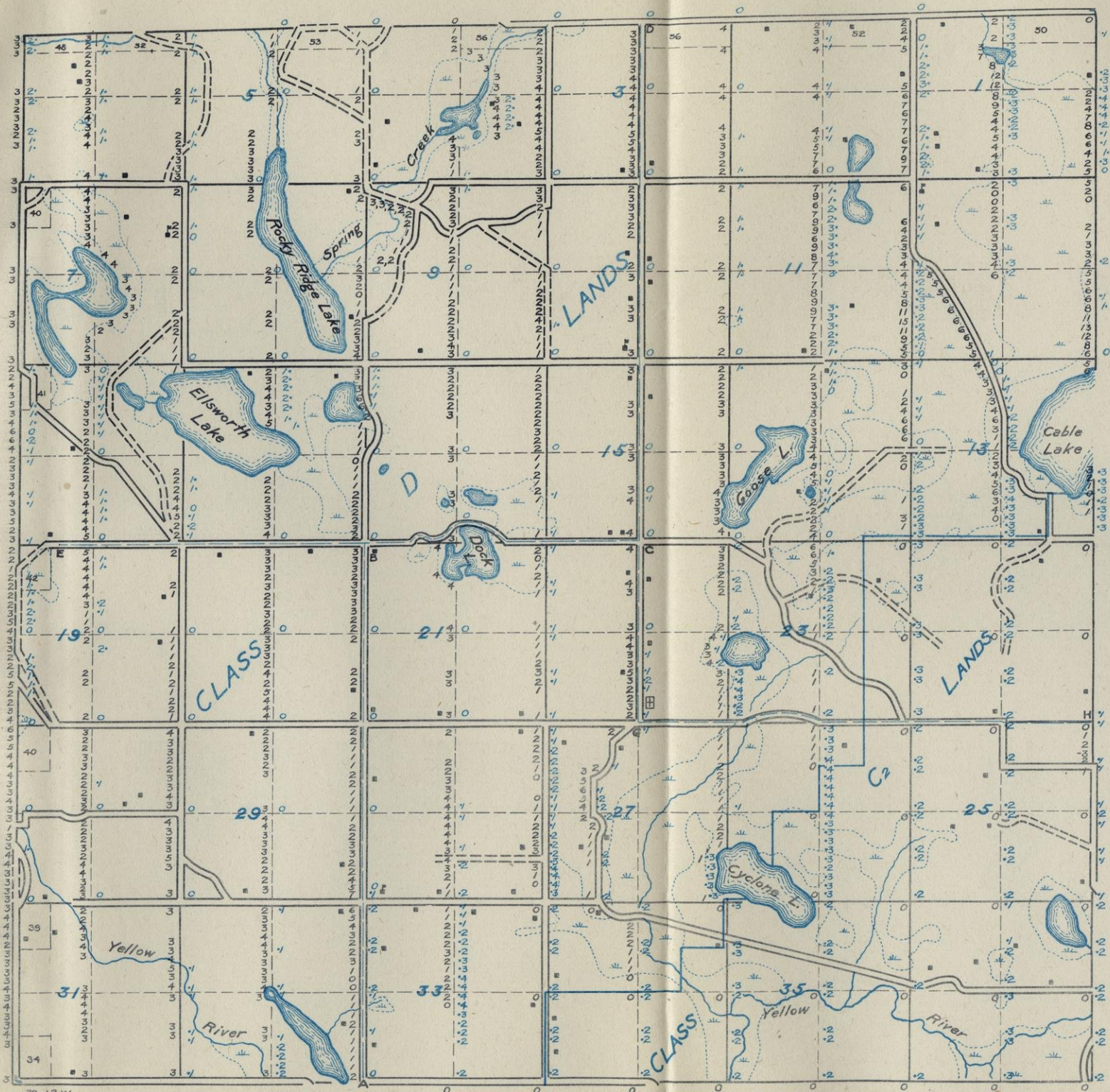

**PROFILES**

VERTICAL SCALE: 1 space = 20'  
HORIZONTAL SCALE: same as map.

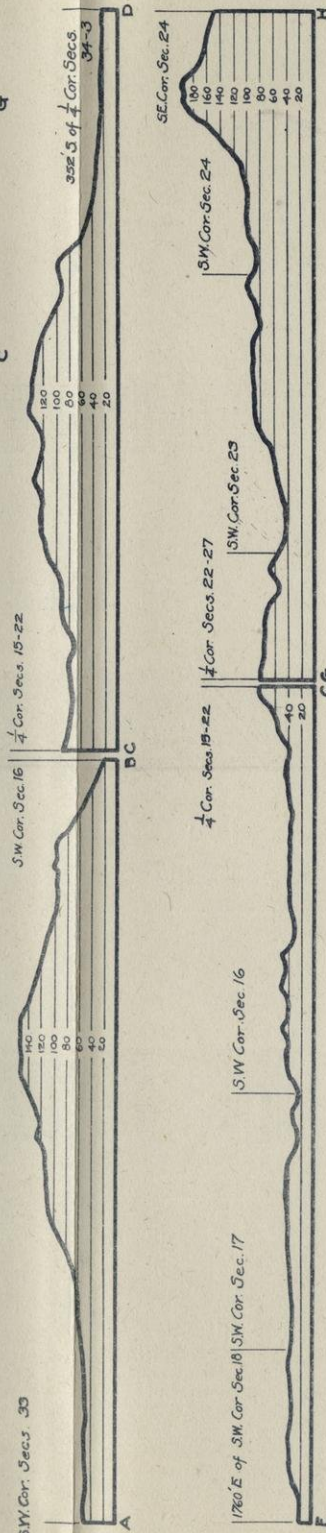
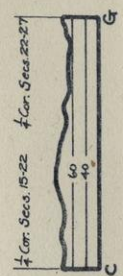

in this vicinity are shallow and none of them reach the ledge. It seems quite probable, however, that quartzite may underlie the extreme northeastern part. A well in the southeast corner of section 28 struck ledge at a depth of 115 feet. This was described as a "hard red sandstone." From this description it may be either a soft phase of the Barron quartzite or Cambrian sandstone. The only other evidence for the character of the underlying rock is given by the magnetic work which indicates that most of this township is underlain by Keweenawan traps. The south boundary of the traps is thought to correspond closely with the land classification lines shown on the map. The non-magnetic southeastern part is probably sandstone or quartzite overlying older rocks about which nothing is known.

*Magnetic Observations.*—A general discussion of magnetic observations and their significance is given in chapter IV. Rather mild and somewhat irregular attractions were found everywhere except in the southeastern corner. The attractions are irregular and do not lie in definite lines. They make instead a magnetic area characteristic of igneous rocks. In instances where readings are the same across a forty they have been indicated only at the corners to avoid crowding numbers on the map.

*Land Classification.*—The principles of land classification employed in this work are discussed in chapter V. All lands in the magnetic part of the township are placed in class D, since there is no possibility of finding iron ore in the Keweenawan traps. The remaining lands are placed in class C2, because the possibility of the existence of an iron formation here is recognized, although there is no evidence for it.

*Exploration.*—Exploration for iron ore in this township cannot be recommended. Only the southeastern part offers any promise and there are no indications to warrant the expenditure of money in search for ore there.

## TOWNSHIP 40 N., RANGE 1. E.

*Surface Features.*—The topography of most of this township is somewhat rough. Some nearly flat areas are found in the central, western and northeastern parts. Most of these are swampy. The North and South Forks of the Flambeau cross the township. Both have eroded the drift sufficiently to give it a rather rugged surface in their vicinity and the dissection of the drift by some of the smaller streams is also quite pronounced. Morainal hills give a certain ruggedness to much of the eastern and northern parts. In this area several small lakes occur. The short profiles show the topography of some of the more level portions only.

Roads are few in number but are generally gravel covered and in good condition. Most of the timber has been removed, but in the northwest part some hardwood still remains. The west half is fairly well settled.

*Glacial Drift.*—A series of terminal moraines occupy the southeastern part of the township and extend brokenly northwest to the region of Blockhouse Lake and then across section 4 to the southeast part of section 5. The moraine is cut by the south fork of Flambeau River in sections 14, 15, 23 and 24 and in sections 23, 34 and 35 it encloses a strip of ground moraine varying in width from  $\frac{1}{2}$  to  $1\frac{1}{2}$  miles. Blockhouse Lake lies close to the east side of the moraine in sections 10 and 15 and is no doubt the result of damming by these glacial deposits. Another terminal moraine about  $\frac{1}{2}$  mile wide extends along Flambeau River in sections 5, 6 and 7. The remainder is ground moraine, covered to a large extent by outwash in the west half of the township. It is badly eroded by the South Fork.

The drift is composed principally of sand, gravel and boulders, with a good covering of silt in the more level places. However, it is characteristically gravelly. Except in the outwash areas large boulders are very common, in some places so much so as to render the land absolutely unfit for agricultural purposes. It is probable that the thickness of the drift is not great in any part of this township. None of the wells reach ledge but all are shallow.

*General Geology.*—In the eastern part of the township are two areas of rock outcrops. Along the southeast side of Blockhouse Lake is an area of about 200 acres containing a very large number of outcrops. A variety of rocks are shown here. What appears to be the oldest rock is a very fine-grained, banded acid schist



which has been intensely folded and metamorphosed. Its general appearance is strongly suggestive of sedimentary origin. Frequently it is very minutely crenulated. Garnets are developed in large numbers. Into this schist have been intruded great masses of coarse pink and white pegmatite which is the most frequently exposed rock. The pegmatite contains crystals of feldspar a foot or more across. Rarely, hornblende crystals several inches in length were observed. Also intruding the acid schist, is a dark coarse grained amphibolite having hornblende crystals about an inch in length. The relation between this and the pegmatite was not ascertained since the two are not exposed in contact. The second group of outcrops occurs in the extreme northeastern corner of section 12 over an area of about 40 acres. The rock is all granite, having crystals  $\frac{1}{2}$  to 1 inch in length, which has been rendered more or less schistose. Biotite is found in all of the exposures.

*Magnetic Observations.*—A general discussion of magnetic observations and their significance is given in chapter IV. Irregular mild attractions are found in sections 3, 4, 5, 8 and 9. These do not connect to form definite magnetic lines of any considerable length and are thought to be due to the presence of a sediment which has been metamorphosed by the intrusion of igneous rocks. A rather strong line of definite attraction extends southwesterly along the Flambeau River in sections 6 and 7. Its character is such as to lead to the belief that it is caused by an iron formation.

*Land Classification.*—Lands in and near the granite in sections 10, 11, 12, 14 and 15 are placed in class D. Lands on the magnetic lines in sections 3, 4, 6, 7, 8 and 9 are placed in class C1 because similar magnetic attractions in the township to the north are known in some instances to be caused by iron formation. All other lands are placed in class C2, although it is probable that all the area south of the magnetic lines is underlain by granite. Owing to the absence of outcrops over such a large area it is not thought advisable to place the lands in class D.

*Exploration.*—The prospects for finding iron ore in this township do not appear good, although some of the magnetic lines are thought quite certainly to be caused by iron formation. Indications are that these formations have been highly anamorphosed and are not likely to contain any considerable ore bodies. However, this can be determined only by exploring them and it therefore

appears that a reasonable amount of exploration on the magnetic lines is warranted. Much of the work done in exploration for iron ore is wasted because of failure to make intelligent use of the geologic and magnetic data to be obtained by a careful preliminary survey, and because the geologic information given by the drill is not properly used as a guide for further work. The value of careful scientific methods of exploration therefore cannot be too strongly emphasized. If exploration is contemplated in this township the discussion of this subject in chapter VI should be carefully studied.

TOWN 40 N., R. 1 E.

Survey Made in August, 1914

Under the Direction of  
W. O. HOTCHKISS, State Geologist

AND  
E. F. BEAN and O. W. WHEELWRIGHT,  
in charge of Field Parties

BY

F. B. PLUMMER, Chief of Party

R. N. HUNT, Asst. Geologist

C. S. GWINN, Asst. Geologist

SYMBOLS AND ABBREVIATIONS.

The symbols and abbreviations used on this map are explained in Chapter II.

TOWN AND RANGE LINES.

In constructing this map the south line of the township was laid off as a true east west line. The other boundary lines were then laid off with the lengths shown on the Land Survey plat. Some of the maps are therefore incorrect in shape but this is necessary because definite facts are lacking. The acreage of part of the lots in the north and west tier of sections is shown to give a check on the distances in these sections.

LOCATIONS.

All locations are based on pacing traverses from government land corners. In many cases these were not found and it was necessary to continue the traverse several miles without a check. Locations of certain features may therefore be somewhat wrong. In such cases the feature sought may best be located by its relation to a stream, swamp, lake, or other feature shown on the map.

PROFILES.

The locations of the profiles are shown on the map by dashed blue lines with black letters at the ends. Railroad profiles were furnished by the companies and show elevations of the ground rather than track in most cases; others are from road surveys by the State Highway Commission; most of them are hand level lines made by this Survey. Wherever possible the elevations above sea level are given. These elevations vary from 1050 to 1770 feet. A local datum plane was necessarily assumed in some cases. These cases are identifiable by the fact that the base line is always numbered 0.

LAND CLASSIFICATION.

This is shown on the map by the blue letters. It is explained in the following township description and at length in chapter V.

MAGNETIC DATA.

Dial compass readings are shown in blue figures. Eastward declinations are shown with a dot to the east and westward with a dot to west of the number. Dip needle readings are shown in black. All are positive except those preceded by the negative sign. All readings show deviation of needles from the normal reading of the instrument used. Normal readings are omitted from the map except at each quarter section corner. All abnormal readings are shown.

Traverses were made on lines indicated—usually the N-S section and quarter lines. Dip needle readings were taken each 50 paces, dial compass readings each 100 paces when permitted.

Magnetic lines are indicated by heavy black lines, solid where definite and dashed where doubtful.

CAUTION: Almost any kind of rock may be the cause of magnetic attraction. Do not fail to read the following description of this township, and also chapter IV., in which the magnetic attractions are discussed.

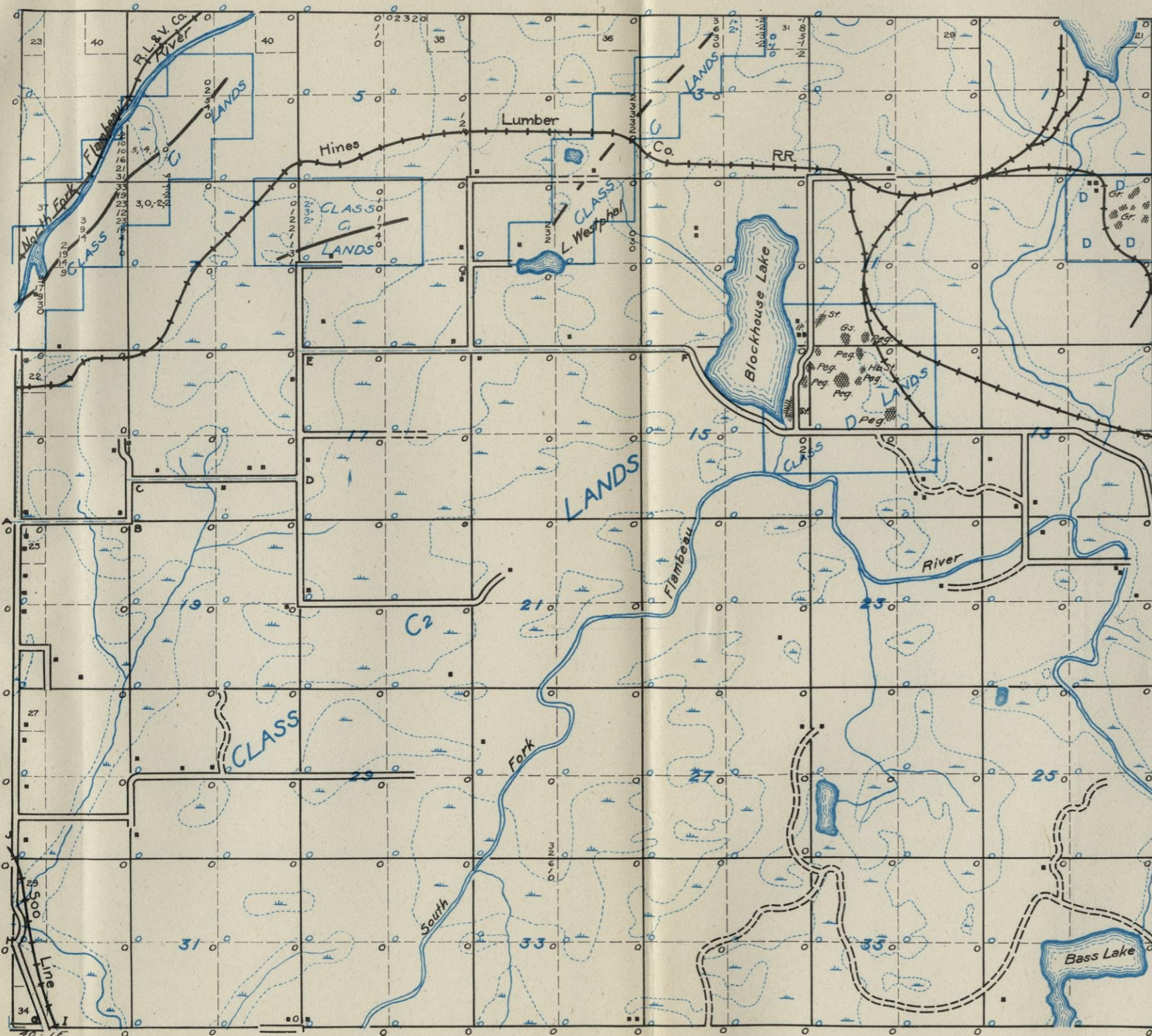

PROFILES

VERTICAL SCALE: 1 space = 20'  
HORIZONTAL SCALE: same as map

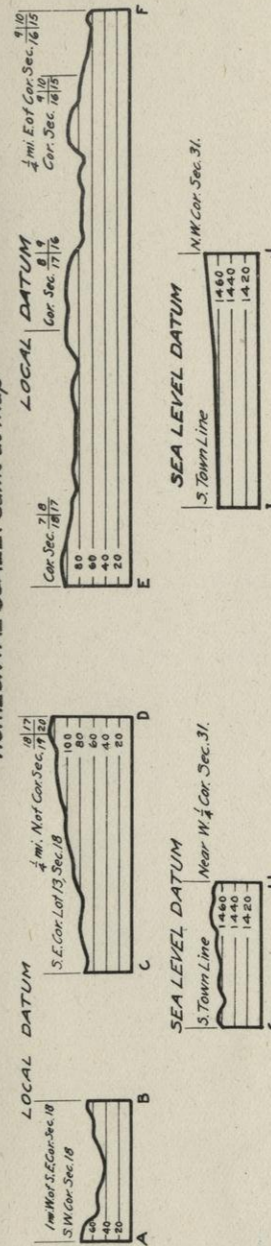

## TOWNSHIP 40 N., RANGE 1 W.

*Surface Features.*—The southwestern and northeastern parts of this township have a gently undulating surface. The southeast part has a fairly level upland surface but it is deeply eroded by Flambeau River and its tributaries giving the topography a rough appearance. A narrow range of low hills crosses from the east central part of section 13 to the northwest quarter of section 21. The topography in the vicinity of Butternut Lake is markedly rough. On the southeast side of the lake the topography is of very rough knob and kettle type. Relief of nearly 100 feet is shown in places and slopes are steep. West of the lake the hills are large but slopes are more gentle. There is a general rise in elevation from the southern to the northern parts. The profiles show the ruggedness of the topography in the lake region and along the river. The railroad profile shows well the rise in elevation from south to north.

This township is well supplied with good roads, many of which have been covered with gravel and are in good condition at all times. The dirt roads are good except in wet weather. There is very little timber left and the land is being rapidly cleared for farms. Flambeau River furnishes water power for milling purposes at Park Falls and to the south in section 25. This power is made use of by the large saw mill, a paper mill and a pulp mill.

*Glacial Drift.*—A narrow belt of terminal moraine extends from the N. E. corner of section 13 to near the center of section 21. The area is rather rugged but of slight relief. Butternut Lake is enclosed by terminal moraines which in some places are rugged but in others form a fairly smooth even ridge. South of these terminal moraines is an eroded outwash plain in which are found numerous small areas of ground moraine, not covered by the outwash deposits. The northeastern part of the township is undulating ground moraine, not as a rule very much eroded by streams. The glacial deposits in the terminal and ground moraines consist of silt, gravel, and sand. Large boulders are very common especially in the terminal moraines. The outwash consists of sand and gravels, and is comparatively free from boulders but in the outwash areas are many patches of bowldery ground moraine.

The thickness of the drift varies from nothing at Flambeau River and on Smith Creek in section 22, to possibly 150 feet or more in the terminal moraines around Butternut Lake. Well records at

Park Falls show that rock is usually encountered at about 70 feet in the higher ground back from the river valley.

*General Geology.*—Rock is exposed at a number of places along the Flambeau River and on Smith Creek in the southeast quarter of section 15. The exposure in section 15 consists entirely of a very coarse white pegmatite in which the feldspar crystals are at times as much as 1 foot across. Along the Flambeau River at the center of section 13 is a very coarse pegmatitic granite having crystals several inches in diameter. At the dam south of the saw mill a very fine biotite schist is intruded by an extremely coarse pegmatite. The schist is very much contorted but it appears to strike about N. 50° or 60° to the east. The lines of schistosity are very well developed and their regularity suggests a possible sedimentary origin for this rock. In section 24 a short distance south of the west quarter post is a small outcrop of coarse granite. At the pulp mill in section 25 the Flambeau River has exposed a section which show a fine chloritic schist and a more acid biotite schist both intruded by red pegmatite in which crystals of feldspar several inches in length are common. The strike of the schistosity is about N. 75° E. and the dip nearly vertical. On both sides of Flambeau River about  $\frac{1}{2}$  mile south of the north quarter post of section 35 are outcrops of coarse pegmatitic granite. It seems quite probable that most of the southeastern part of this township is underlain by rocks of the type above described. There is no evidence as to the character of the underlying rock in the remainder of the township except such as is indicated by the magnetic attractions. These suggest that it is an area of Huronian rocks which in all probability contain some iron formation.

• *Magnetic Observations.*—A general discussion of magnetic observations and their significance is given in Chapter IV. A fairly well defined line of magnetic attraction is found in the south half of section 10 and 11. The line is short and the attraction rather mild in character, but its regularity suggests that it is probably caused by a sedimentary formation. Rather mild attraction is found immediately south of the outcropping rocks at the pulp mill above described, and it is believed that this is caused by magnetite in the schists. Fairly regular attraction is found in sections 31 and 32. This is considerably stronger than in the other locations described, and is continuous for some distance in the township to the southwest where it is even more regular. In the townships adjoining to the northeast attractions similar to these have been proven to be caused

TOWN 40 N., R. 1W.

Survey Made in June, 1914

Under the Direction of

W. O. HOTCHKISS, State Geologist

AND

E. F. BEAN and O. W. WHEELWRIGHT,  
in charge of Field Parties

BY

F. B. PLUMMER, Chief of Party

R. N. HUNT, Asst. Geologist

C. S. GWINN, Asst. Geologist

SYMBOLS AND ABBREVIATIONS.

The symbols and abbreviations used on this map are explained in Chapter II.

TOWN AND RANGE LINES.

In constructing this map the south line of the township was laid off as a true east west line. The other boundary lines were then laid off with the lengths shown on the Land Survey plat. Some of the maps are therefore incorrect in shape but this is necessary because definite facts are lacking. The acreage of part of the lots in the north and west tier of sections is shown to give a check on the distances in these sections.

LOCATIONS.

All locations are based on pacing traverses from government land corners. In many cases these were not found and it was necessary to continue the traverse several miles without a check. Locations of certain features may therefore be somewhat wrong. In such cases the feature sought may best be located by its relation to a stream, swamp, lake, or other feature shown on the map.

PROFILES.

The locations of the profiles are shown on the map by dashed blue lines with black letters at the ends. Railroad profiles were furnished by the companies and show elevations of the ground rather than track in most cases; others are from road surveys by the State Highway Commission; most of them are hand level lines made by this Survey. Wherever possible the elevations above sea level are given. These elevations vary from 1050 to 1770 feet. A local datum plane was necessarily assumed in some cases. These cases are identifiable by the fact that the base line is always numbered 0.

LAND CLASSIFICATION.

This is shown on the map by the blue letters. It is explained in the following township description and at length in chapter V.

MAGNETIC DATA.

Dial compass readings are shown in blue figures. Eastward declinations are shown with a dot to the east and westward with a dot to west of the number. Dip needle readings are shown in black. All are positive except those preceded by the negative sign. All readings show deviation of needles from the normal reading of the instrument used. Normal readings are omitted from the map except at each quarter section corner. All abnormal readings are shown.

Traverses were made on lines indicated—usually the N-S section and quarter lines. Dip needle readings were taken each 50 paces, dial compass readings each 100 paces when sun permitted.

Magnetic lines are indicated by heavy black lines, solid where definite and dashed where doubtful.

CAUTION: Almost any kind of rock may be the cause of magnetic attraction. Do not fail to read the following description of this township, and also chapter IV., in which the magnetic attractions are discussed.

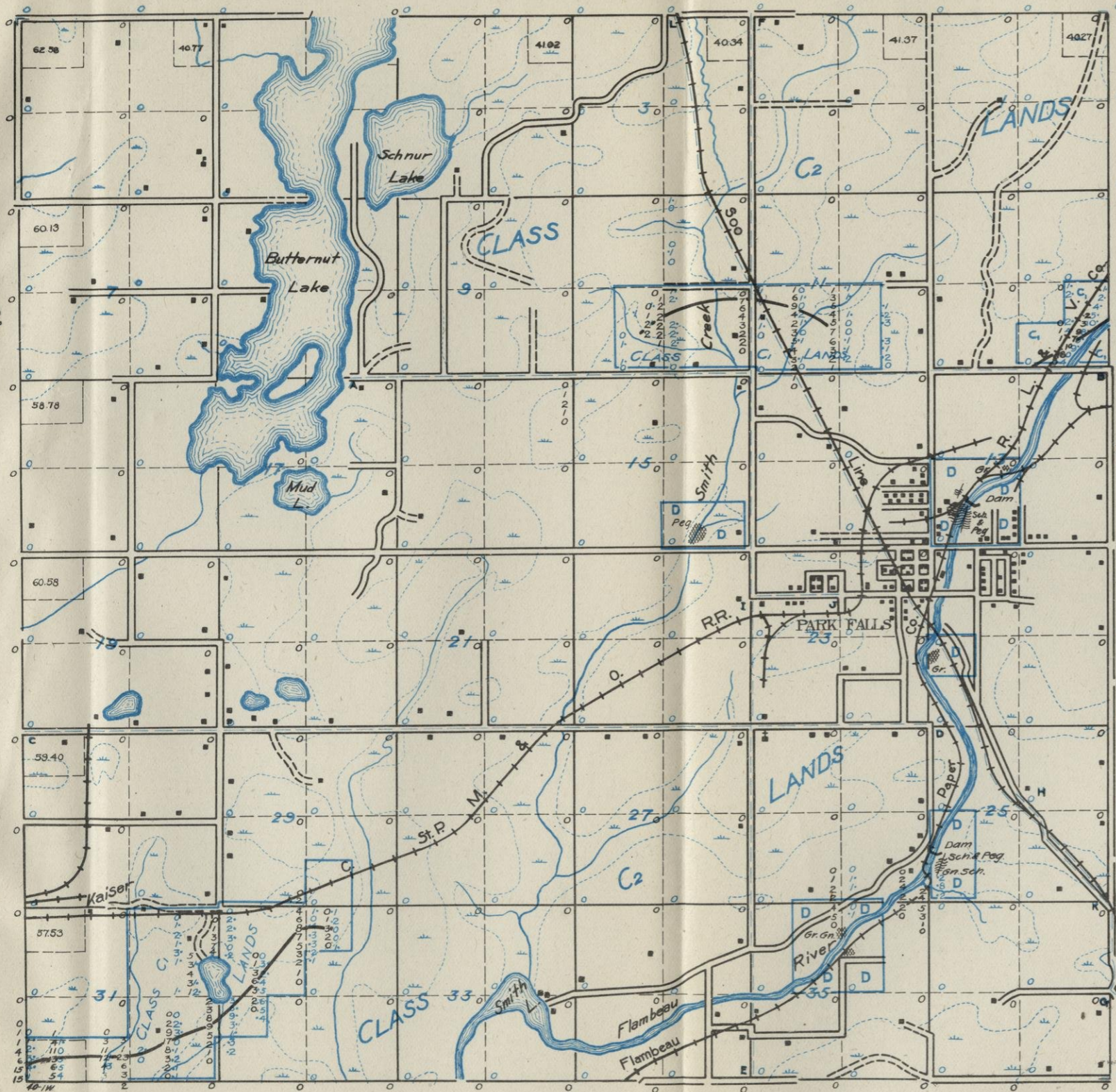

PROFILE  
VERTICAL SCALE: 1 space = 20'  
HORIZONTAL SCALE: same as map

SEA LEVEL DATUM

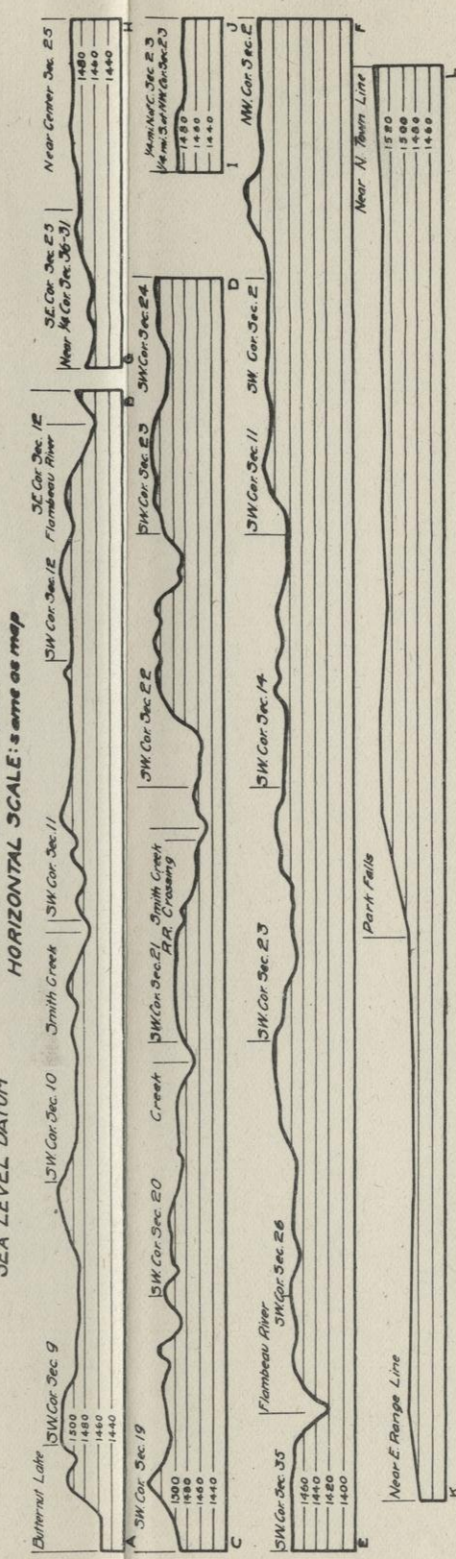

31° 00'

40-1W

by iron formation and it is very probable that the attractions in this township are due to the same cause.

*Land Classification.*—The principles of land classification employed in this work are discussed in chapter V. Lands in the immediate vicinity of the outcrops are placed in class D. Those lands on the magnetic lines in sections 10, 11, 29, 30 and 31 are classed as C1 because it is thought probable that these lines indicate magnetic iron formations. All other lands in the township are placed in class C2. Without doubt many of these are underlain by granites, but lack of definite information makes it impossible to separate them from those which might possibly contain iron formation.

*Exploration.*—None of the lands in this township offer particular promise for the discovery of iron ores, but the lands classed as C1 offer the best prospects. The iron formation mentioned as occurring in the township to the northeast is itself of such a nature that ore bodies of considerable size are not likely to be found in it, and therefore it is thought that these C1 lands offer little encouragement to the explorer. This is a part of an area comprising several townships where a number of good magnetic lines are found. Information gained on any one of them will be of general application to the area. Being farther from known intrusions of granite the magnetic lines to the west appear rather more favorable as places to explore than those in this township. Interested parties should read the report of the adjoining townships and carefully study Chapter VI which deals with the general problems of exploration. Much of the work done in exploration for iron ore is wasted because of failure to make intelligent use of the geologic and magnetic data to be obtained by a careful preliminary survey, and because the geologic information given by the drill is not properly used as a guide for further work. The value of careful scientific methods of exploration therefore cannot be too strongly emphasized. If exploration is contemplated in this township the discussion of this subject in Chapter VI should be carefully studied.

## TOWNSHIP 40 N., RANGE 2 W.

*Surface Features.*—The topography of this township is gently undulating and the relief is very slight, except in the extreme northeastern part, where some high hills are found. The creeks crossing the township usually have wide valleys but in places have cut deeply into the drift and have banks as much as 50 feet in height. A few small lakes are found in small depressions in the glacial drift. The accompanying profile along the line of the C. St. P. M. & O. railroad shows the character of the surface, including the valley eroded by Butternut Creek.

This township is very poorly supplied with roads and such as exist are in very poor condition at the present time. There was originally a large quantity of hardwood timber, but most of it has been recently removed and little is left now except in sections 3, 10 and 15, and along the south line in sections 33, 34, 35 and 36. Settlers are very few except in the northeastern part and at Kennedy.

*Glacial Drift.* The entire township is covered with ground moraine deposits. The relief in the northeastern part is suggestive of terminal moraine, but the other characteristics of this type of deposit are lacking. The drift is composed of silt, sand and boulders. Boulders are widely distributed and in places are very numerous.

There are no data to indicate the depth of the glacial drift covering. One well in the high northeastern part is down 60 feet without reaching ledge.

*General Geology.*—There are no exposures of rock in this township nor any closer than those along the Flambeau River at Park Falls. The results of the magnetic work lead to the conclusion that the underlying rocks are Huronian.

*Magnetic Observations.*—A general discussion of magnetic observations and their significance is given in Chapter IV. Two well defined lines of magnetic attraction are found in this township in addition to a number of areas of rather mild irregular attraction. One of these lines runs west from the S.  $\frac{1}{4}$  S. of section 10, passing into the township west near the W.  $\frac{1}{4}$  S. of section 7. Dip needle attractions as high as  $15^{\circ}$  were obtained in crossing this line. The attraction is regular in character and is suggestive of an iron formation. A somewhat milder but very definite line of attraction extends across the north half of sections 26, 27, 28, 29 and 30 and con-



TOWN 40 N., R. 2W.

Survey Made in September, 1914

Under the Direction of  
W. O. HOTCHKISS, State Geologist  
AND  
E. F. BEAN and O. W. WHEELWRIGHT,  
in charge of Field Parties

BY  
F. B. PLUMMER, Chief of Party  
R. H. HUNT, Asst. Geologist  
C. S. GWINN, Asst. Geologist  
LOUIS ROARK, Asst. Geologist

SYMBOLS AND ABBREVIATIONS.

The symbols and abbreviations used on this map are explained in Chapter II.

TOWN AND RANGE LINES.

In constructing this map the south line of the township was laid off as a true east west line. The other boundary lines were then laid off with the lengths shown on the Land Survey plat. Some of the maps are therefore incorrect in shape but this is necessary because definite facts are lacking. The acreage of part of the lots in the north and west tier of sections is shown to give a check on the distances in these sections.

LOCATIONS.

All locations are based on pacing traverses from government land corners. In many cases these were not found and it was necessary to continue the traverse several miles without a check. Locations of certain features may therefore be somewhat wrong. In such cases the feature sought may best be located by its relation to a stream, swamp, lake, or other feature shown on the map.

PROFILES.

The locations of the profiles are shown on the map by dashed blue lines with black letters at the ends. Railroad profiles were furnished by the companies and show elevations of the ground rather than track in most cases; others are from road surveys by the State Highway Commission; most of them are hand level lines made by this Survey. Wherever possible the elevations above sea level are given. These elevations vary from 1050 to 1770 feet. A local datum plane was necessarily assumed in some cases. These cases are identifiable by the fact that the base line is always numbered 0.

LAND CLASSIFICATION.

This is shown on the map by the blue letters. It is explained in the following township description and at length in chapter V.

MAGNETIC DATA.

Dial compass readings are shown in blue figures. Eastward declinations are shown with a dot to the east and westward with a dot to west of the number. Dip needle readings are shown in black. All are positive except those preceded by the negative sign. All readings show deviation of needles from the normal reading of the instrument used. Normal readings are omitted from the map except at each quarter section corner. All abnormal readings are shown.

Traverses were made on lines indicated—usually the N-S section and quarter lines. Dip needle readings were taken each 50 paces, dial compass readings each 100 paces when sun permitted.

Magnetic lines are indicated by heavy black lines, solid where definite and dashed where doubtful.

CAUTION: Almost any kind of rock may be the cause of magnetic attraction. Do not fail to read the following description of this township, and also chapter IV., in which the magnetic attractions are discussed.

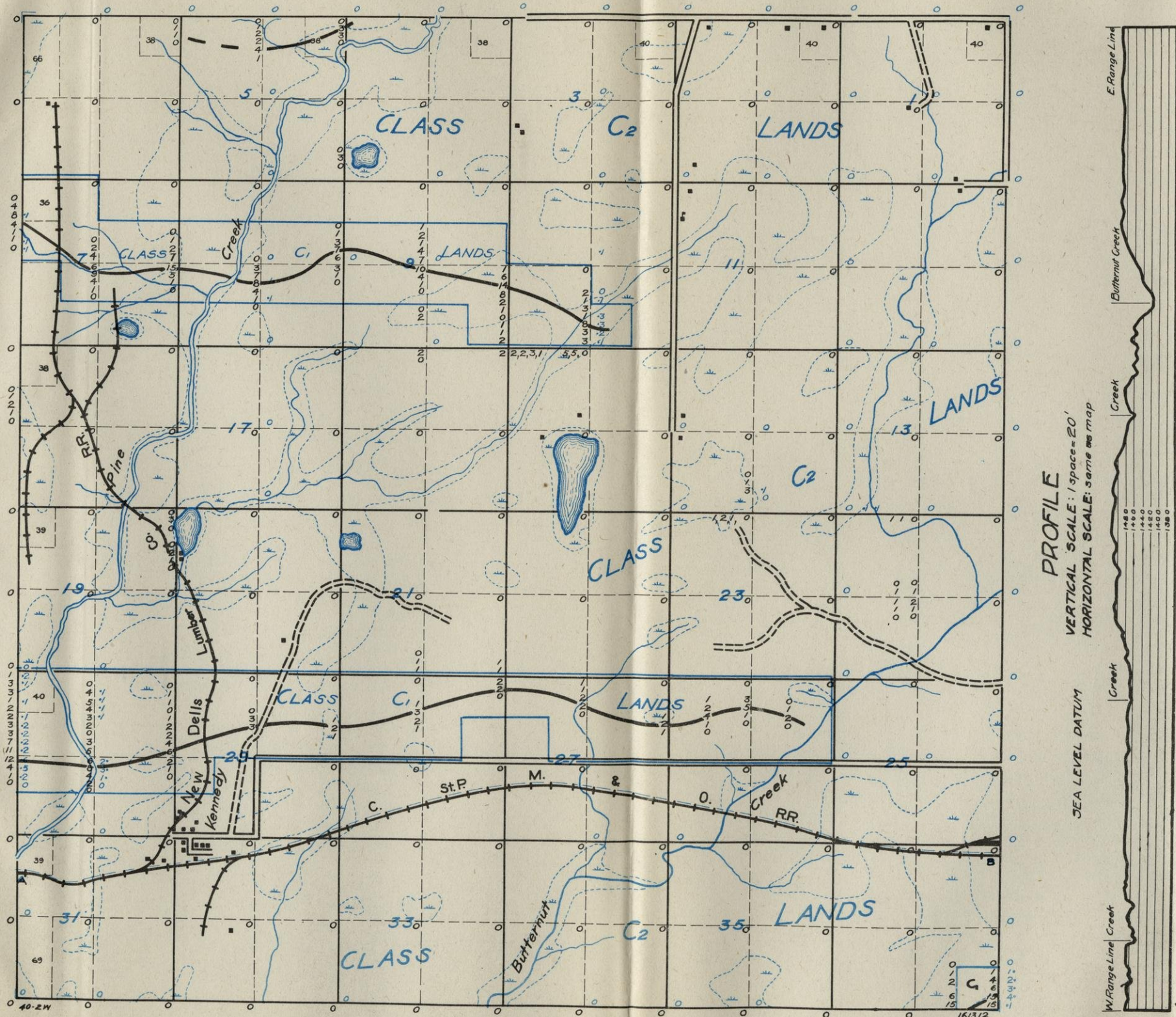

tinues in the township to the west. In character this is also such as suggests iron formation. A very short line is found in the north half of section 5. In the extreme southeastern part of the township is an area of strong attraction which is part of a line extending from T. 40-1 W. and T. 39-2 W.

*Land Classification.*—For the principles of land classification employed in this work the reader is referred to Chapter V. All lands on the two better defined magnetic lines are placed in class C1. Other lands in this township are laced in class C2.

*Exploration.*—It is very probable that the better magnetic lines in this township are caused by iron formation. Whether or not this is the highly anamorphosed non-productive type found to the east of Butternut can be determined only by exploration. The attractions are not strong and are of such character as to encourage the belief that iron ore may be found. A reasonable amount of drilling on these lines is advised. Much of the work done in exploration for iron ore is wasted because of failure to make intelligent use of the geologic and magnetic data to be obtained by a careful preliminary survey, and because the geologic information given by the drill is not properly used as a guide for further work. The value of careful scientific methods of exploration therefore cannot be too strongly emphasized. If exploration is contemplated in this township the discussion of this subject in Chapter VI should be carefully studied.

## TOWNSHIP 40 N., RANGE 3 W.

*Surface Features.*—This township is characteristically flat and poorly drained. Extensive swamps are numerous. Relief of more than 25 to 30 feet is very uncommon. The C. St. P. M. & O. Railway profile shows the general elevation to be about 1460 feet above sea level. The township drains into the Chippewa, Brunet, Thornapple and Flambeau rivers. Pine Creek in the southeastern corner has cut deeply into the drift and has steep-sided valley about 50 feet high.

The only roads in the township are unused tote roads which are nearly impassable even in the most favorable seasons. Much hemlock and hardwood timber remains in the township and logging operations are active. Some pine formerly existed in the northwest and southeast corners. Because of the fact that the lumbering industry has not yet thrown this country open to settlement there are no farms in the township.

*Glacial Drift.*—Nearly all of the drift is in the form of ground moraine deposits, but parts of sections 5, 6, and 7, 24, and 36 are poorly developed terminal moraines. The relief is very slight and the moraine is indistinctly shown. The glacial drift consists of silt, sand and boulders, with gravel in some places. The few exposed sections in the terminal moraine areas are more sandy than the remainder of the township.

The thickness of drift is not known because there are no rock exposures nor wells in the township, but it is thought that it will usually exceed 100 feet in the southern part. In the northern part it is probably not so deep.

*General Geology.*—No exposures of rock are found in this township nor are any found in the adjoining townships and as a consequence definite information regarding the character of underlying rock is lacking. As a result of the magnetic work done it is believed that all of the township except a small area in the northwestern part is underlain by Huronian rocks.

*Magnetic Observations.*—A general discussion of magnetic observations and their significance is given in Chapter IV. There is a line of attraction extending from section 25 to the N. E.  $\frac{1}{4}$  of section 29. This is a continuation of a line found in the township to the east. Its total length is 9 miles and its effect is distinctly felt on every traverse. Another line of attraction, rather indefinite in character,

TOWN 40 N., R. 3W.

Survey Made in August, 1914

Under the Direction of  
W. O. HOTCHKISS, State Geologist  
AND  
E. F. BEAN and O. W. WHEELWRIGHT,  
in charge of Field Parties

BY  
H. J. ALLEN, Chief of Party  
C. R. SCHROYER, Asst. Geologist  
E. L. JAY, Asst. Geologist

**SYMBOLS AND ABBREVIATIONS.**  
The symbols and abbreviations used on this map are explained in Chapter II.

**TOWN AND RANGE LINES.**  
In constructing this map the south line of the township was laid off as a true east west line. The other boundary lines were then laid off with the lengths shown on the Land Survey plat. Some of the maps are therefore incorrect in shape but this is necessary because definite facts are lacking. The acreage of part of the lots in the north and west tier of sections is shown to give a check on the distances in these sections.

**LOCATIONS.**  
All locations are based on pacing traverses from government land corners. In many cases these were not found and it was necessary to continue the traverse several miles without a check. Locations of certain features may therefore be somewhat wrong. In such cases the feature sought may best be located by its relation to a stream, swamp, lake, or other feature shown on the map.

**PROFILES.**  
The locations of the profiles are shown on the map by dashed blue lines with black letters at the ends. Railroad profiles were furnished by the companies and show elevations of the ground rather than track in most cases; others are from road surveys by the State Highway Commission; most of them are hand level lines made by this Survey. Wherever possible the elevations above sea level are given. These elevations vary from 1050 to 1770 feet. A local datum plane was necessarily assumed in some cases. These cases are identifiable by the fact that the base line is always numbered 0.

**LAND CLASSIFICATION.**  
This is shown on the map by the blue letters. It is explained in the following township description and at length in chapter V.

**MAGNETIC DATA.**  
Dial compass readings are shown in blue figures. Eastward declinations are shown with a dot to the east and westward with a dot to west of the number. Dip needle readings are shown in black. All are positive except those preceded by the negative sign. All readings show deviation of needles from the normal reading of the instrument used. Normal readings are omitted from the map except at each quarter section corner. All abnormal readings are shown.

Traverses were made on lines indicated—usually the N-S section and quarter lines. Dip needle readings were taken each 50 paces, dial compass readings each 100 paces when sun permitted.

Magnetic lines are indicated by heavy black lines, solid where definite and dashed where doubtful.

**CAUTION:** Almost any kind of rock may be the cause of magnetic attraction. Do not fail to read the following description of this township, and also chapter IV., in which the magnetic attractions are discussed.

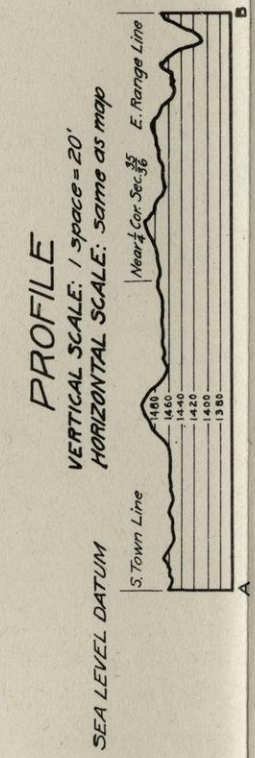
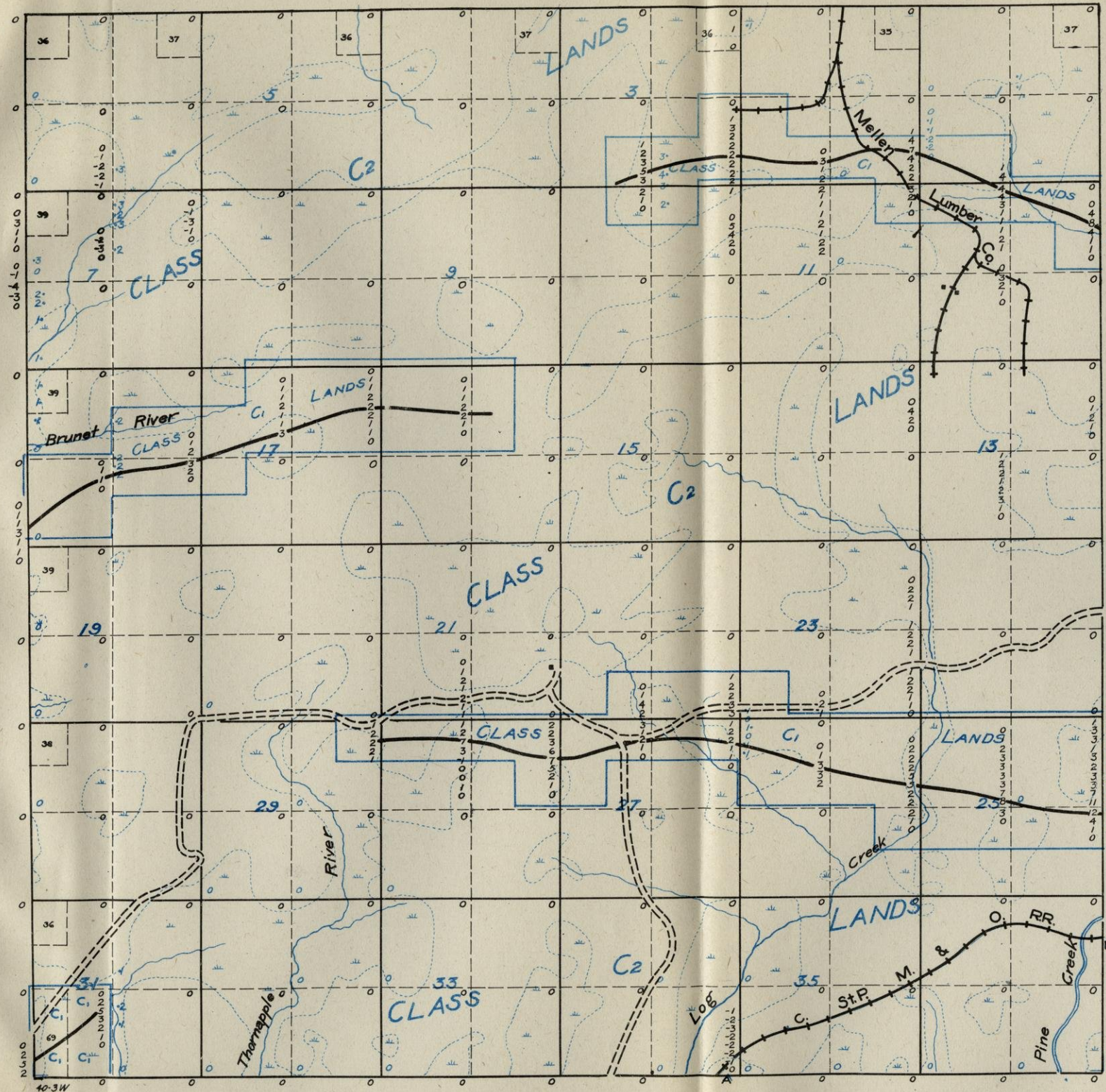

was found along the south side of sections 1, 2 and 3. This is also continuous to the east for a distance of 4 miles making a total length of 7 miles. A milder line crosses section 16, 17 and 18 and continues for more than 4 miles in T. 40-4W. making its total length 7 miles. The attraction indicated in section 31 is continuous in the townships to the west, where it also extends for some distance. In various other places in the township irregular dip and dial readings were obtained, but they do not lie in definite lines. Lines of the length and degree of regularity of those described above indicate strongly the presence of iron formations.

*Land Classification.*—The principles of land classification employed in this work are discussed in chapter V. Those lands on the best defined lines of attraction are placed in class C1. Other lands in the township are classed as C2.

*Exploration.*—A moderate amount of exploration on some of these better magnetic lines seems warranted. There is very good reason for believing that iron formation causes these attractions but it is not possible to state whether it is of a type likely to prove productive until some drilling has been done. Much of the work done in exploration for iron ore is wasted because of failure to make intelligent use of the geologic and magnetic data to be obtained by a careful preliminary survey, and because the geologic information given by the drill is not properly used as a guide for further work. The value of careful scientific methods of exploration therefore cannot be too strongly emphasized. If exploration is contemplated in this township the discussion of this subject in Chapter VI should be carefully studied.

## TOWNSHIP 40 N., RANGE 4 W.

*Surface Features.*—The general elevation of this township is high but relief of more than 30 to 40 feet is very uncommon. The surface is markedly uneven in the southwestern part but elsewhere is gently undulating. Drainage is sluggish and there is much swamp land. The Chippewa River crosses the northwestern part and widens out in sections 17 and 20 to form a shallow lake which is grown up to wild rice.

There are no roads except the tote roads of the logging companies which are difficult to travel. There are no settlers in the township. Considerable quantities of hardwood and hemlock timber still remain. The southwestern part was originally timbered with pine which has been entirely removed.

*Glacial Drift.*—Most of the township is ground moraine, but several sections in the southwestern part have terminal moraine topography which extends into the township to the south. The relief here is not great but slopes are steep and the surface is rough. Small lakes and swamps are of common occurrence. The drift in the ground moraine areas consist of silt, sand, gravel and boulders, and in the terminal moraine area is sand, gravel and boulders.

There are no wells to show the depth of the drift but rock is exposed along the Chippewa River in section 4 which indicates that it is comparatively thin for this part of the township. It probably becomes deeper toward the south and may exceed 100 feet in many places.

*General Geology.*—Along the Chippewa River in the south half of section 4 are several exposures of rock which consist of fine-grained hornblende schist intruded by a fine-grained syenite. The schistosity is usually very well developed and in places is suggestive of bedding in a sedimentary formation. The strike is N. 85° E. and the dip about vertical, except in the northernmost outcrop where it is less well developed and appears to strike about N. 35° E. All gradations between the clean syenite and the schist are found, indicating a marked chemical reaction at the time of intrusion. The hornblende schist is somewhat magnetic in hand specimens and the dip needle shows slight attractions over the outcrop. There are no other exposures of rocks in this township. The results of the magnetic work indicates that most of the township is a Huronian area but some igneous rocks are also thought to be present as shown on the geological map, plate I.

## TOWN 40 N., R. 4W.

Survey Made in August, 1914

Under the Direction of

W. O. HOTCHKISS, State Geologist

AND

E. F. BEAN and O. W. WHEELWRIGHT,  
in charge of Field Parties

BY

H. J. ALLEN, Chief of Party

C. R. SCHROYER, Asst. Geologist

E. L. JAY, Asst. Geologist

### SYMBOLS AND ABBREVIATIONS.

The symbols and abbreviations used on this map are explained in Chapter II.

### TOWN AND RANGE LINES.

In constructing this map the south line of the township was laid off as a true east west line. The other boundary lines were then laid off with the lengths shown on the Land Survey plat. Some of the maps are therefore incorrect in shape but this is necessary because definite facts are lacking. The acreage of part of the lots in the north and west tier of sections is shown to give a check on the distances in these sections.

### LOCATIONS.

All locations are based on pacing traverses from government land corners. In many cases these were not found and it was necessary to continue the traverse several miles without a check. Locations of certain features may therefore be somewhat wrong. In such cases the feature sought may best be located by its relation to a stream, swamp, lake, or other feature shown on the map.

### PROFILES.

The locations of the profiles are shown on the map by dashed blue lines with black letters at the ends. Railroad profiles were furnished by the companies and show elevations of the ground rather than track in most cases; others are from road surveys by the State Highway Commission: most of them are hand level lines made by this Survey. Wherever possible the elevations above sea level are given. These elevations vary from 1050 to 1770 feet. A local datum plane was necessarily assumed in some cases. These cases are identifiable by the fact that the base line is always numbered 0.

### LAND CLASSIFICATION.

This is shown on the map by the blue letters. It is explained in the following township description and at length in chapter V.

### MAGNETIC DATA.

Dial compass readings are shown in blue figures. Eastward declinations are shown with a dot to the east and westward with a dot to west of the number. Dip needle readings are shown in black. All are positive except those preceded by the negative sign. All readings show deviation of needles from the normal reading of the instrument used. Normal readings are omitted from the map except at each quarter section corner. All abnormal readings are shown.

Traverses were made on lines indicated—usually the N-S section and quarter lines. Dip needle readings were taken each 50 paces, dial compass readings each 100 paces when sun permitted.

Magnetic lines are indicated by heavy black lines, solid where definite and dashed where doubtful.

**CAUTION:** Almost any kind of rock may be the cause of magnetic attraction. Do not fail to read the following description of this township, and also chapter IV., in which the magnetic attractions are discussed.

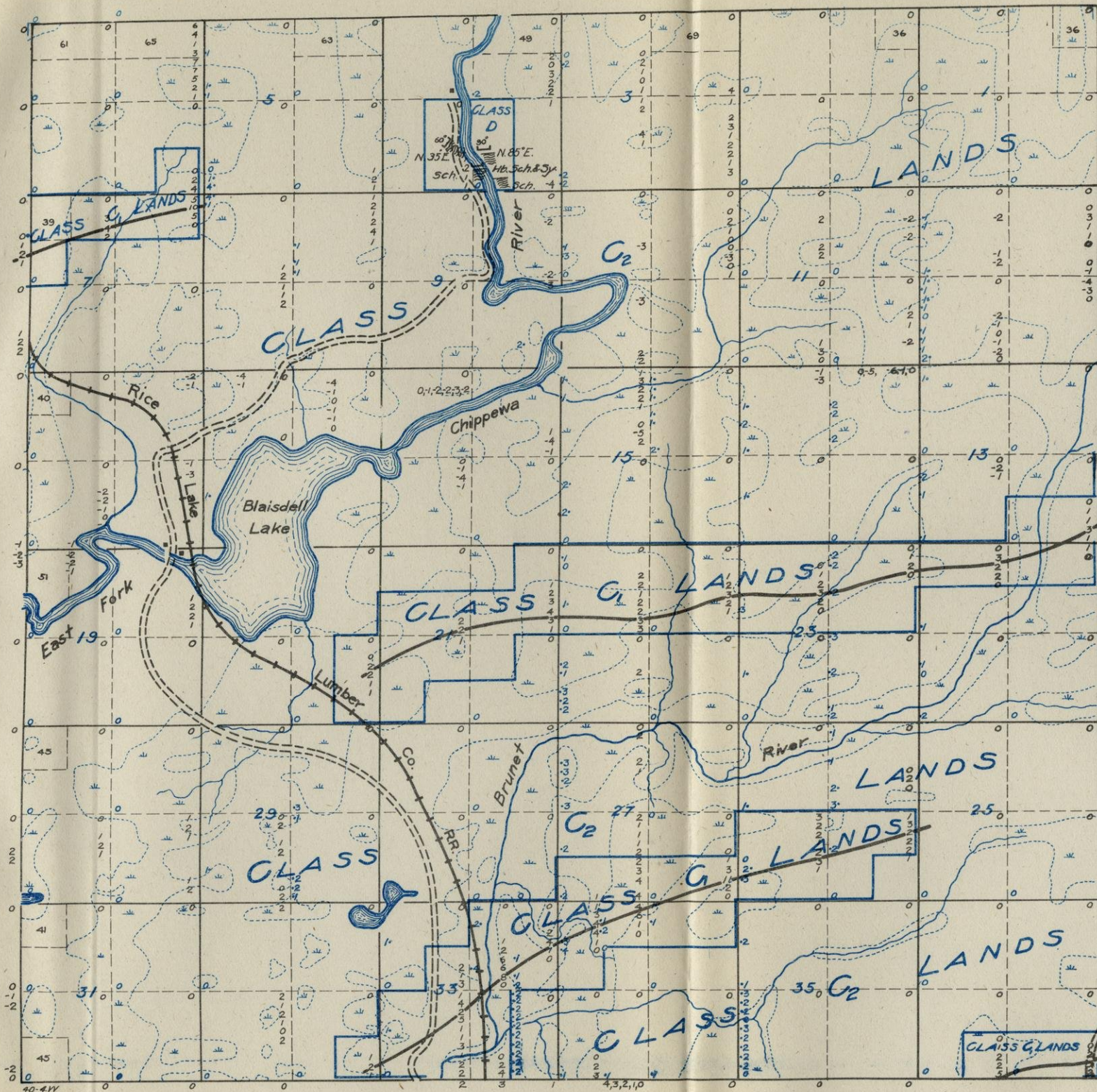

*Magnetic Observations.*—A general discussion of magnetic observations and their significance is given in Chapter IV. Mild deflections of both dip and dial compasses were obtained in many parts of this township, but there are only three well developed magnetic lines. One of these extends from section 21 to the north quarter post of section 24 and is continuous with the line in sections 16, 17 and 18 of the township to the east. The second line extends across sections 26, 27, 33 and 34. In the north half of section 7 is a shorter line extending into the township to the west. In the southeastern corner of section 36 is a line of attraction better developed in the township to the east and south. The remainder of the attractions are too irregular to be considered as magnetic lines. The very persistent character of most of these magnetic lines strongly suggest that they are caused by iron formations. The negative attractions north of the center line of the township probably indicate the presence of igneous rock.

*Land Classification.*—A general discussion of the principles of land classification employed in this work is given in Chapter V. Lands in the immediate vicinity of exposed rocks in section 4 are placed in class D. Lands along the best defined magnetic lines are placed in class C1 and other lands in the township are classed as C2, because of lack of information as to the character of the underlying rock. The evidence for the presence of igneous rock in the area of negative attractions is not considered sufficiently conclusive to warrant a D classification for these lands.

*Exploration.*—It is believed that lands in the immediate vicinity of the best defined magnetic lines offer some promise as iron ore prospects and a reasonable amount of exploration work on them is warranted. Because of the persistent character of the line and mildness of the attraction the line in the center of the township is looked upon with the most favor. Work should not be confined to the lines themselves, but should be extended to some distance on either side in order to determine definitely whether an iron formation exists. Much of the work done in exploration for iron ore is wasted because of failure to make intelligent use of the geologic and magnetic data to be obtained by a careful preliminary survey, and because the geologic information given by the drill is not properly used as a guide for further work. The value of careful scientific methods of exploration therefore cannot be too strongly emphasized. If exploration is contemplated in this township the discussion of this subject in chapter VI should be carefully studied.



## TOWNSHIP 40 N., RANGE 5 W.

*Surface Features.*—The surface of this township is gently undulating with relief of not more than 70 feet at any point and usually much less than this. The Chippewa River has not cut deeply into the drift covering and in two places has widened out to form shallow lakes. The flow is sluggish from the eastern boundary line to the outlet of Barker Lake, beyond which point it descends very rapidly to join the West Fork which has eroded much more deeply into the drift. Several small lakes occupy shallow depressions in the drift in the eastern part.

This township is entirely lacking in improved roads, there being nothing but practically impassable tote roads. Most of the timber has been removed but logging operations are still going on in the township. Fires have destroyed a large amount of timber. Largely because of its inaccessibility only two settlers are living in the township at the present time.

*Glacial Drift.*—Most of the township is covered with ground moraine, which has a gently undulating surface and is not eroded to any great extent even along the Chippewa River. Rugged terminal moraine occurs in sections 4 and 5 and it is here that the greatest relief in the township is found. The extreme southeastern part of the township has some very weak terminal moraine. The drift whether terminal or ground moraine, consists of silt, sand and boulders, with some gravel. There is nothing to indicate the depth of drift but it is probably nearly 100 feet in all parts of the township.

*General Geology.*—No outcrops occur and no definite idea of the character of the underlying rocks can be obtained. As a result of the magnetic work it seems probable that igneous rocks underlie most of the southern half and that the northern half of the township is in a Huronian area.

*Magnetic Observations.*—A general discussion of magnetic observations and their significance is given in Chapter IV. Mild irregular attractions, both positive and negative in character, are obtained generally over this township; but in only two instances do they appear to form even poorly defined magnetic lines. A short line is drawn connecting the mild attractions in the north half of sections 10 and 11 and there is a suggestion of a line running from the north quarter post of 15 to near the north quarter post of section 12. Sedimentary formations probably cause these attractions but the

TOWN 40 N., R. 5 W.

Survey Made in August, 1914

Under the Direction of

W. O. HOTCHKISS, State Geologist

AND

E. F. BEAN and O. W. WHEELWRIGHT,

in charge of Field Parties

BY

J. P. GOLDSBERRY, Chief of Party

C. W. HONESS, Asst. Geologist

T. M. LANGLEY, Asst. Geologist

SYMBOLS AND ABBREVIATIONS.

The symbols and abbreviations used on this map are explained in Chapter II.

TOWN AND RANGE LINES.

In constructing this map the south line of the township was laid off as a true east west line. The other boundary lines were then laid off with the lengths shown on the Land Survey plat. Some of the maps are therefore incorrect in shape but this is necessary because definite facts are lacking. The acreage of part of the lots in the north and west tier of sections is shown to give a check on the distances in these sections.

LOCATIONS.

All locations are based on pacing traverses from government land corners. In many cases these were not found and it was necessary to continue the traverse several miles without a check. Locations of certain features may therefore be somewhat wrong. In such cases the feature sought may best be located by its relation to a stream, swamp, lake, or other feature shown on the map.

PROFILES.

The locations of the profiles are shown on the map by dashed blue lines with black letters at the ends. Railroad profiles were furnished by the companies and show elevations of the ground rather than track in most cases; others are from road surveys by the State Highway Commission: most of them are hand level lines made by this Survey. Wherever possible the elevations above sea level are given. These elevations vary from 1050 to 1770 feet. A local datum plane was necessarily assumed in some cases. These cases are identifiable by the fact that the base line is always numbered 0.

LAND CLASSIFICATION.

This is shown on the map by the blue letters. It is explained in the following township description and at length in chapter V.

MAGNETIC DATA.

Dial compass readings are shown in blue figures. Eastward declinations are shown with a dot to the east and westward with a dot to west of the number. Dip needle readings are shown in black. All are positive except those preceded by the negative sign. All readings show deviation of needles from the normal reading of the instrument used. Normal readings are omitted from the map except at each quarter section corner. All abnormal readings are shown.

Traverses were made on lines indicated—usually the N-S section and quarter lines. Dip needle readings were taken each 50 paces, dial compass readings each 100 paces when sun permitted.

Magnetic lines are indicated by heavy black lines, solid where definite and dashed where doubtful.

CAUTION: Almost any kind of rock may be the cause of magnetic attraction. Do not fail to read the following description of this township, and also chapter IV., in which the magnetic attractions are discussed.

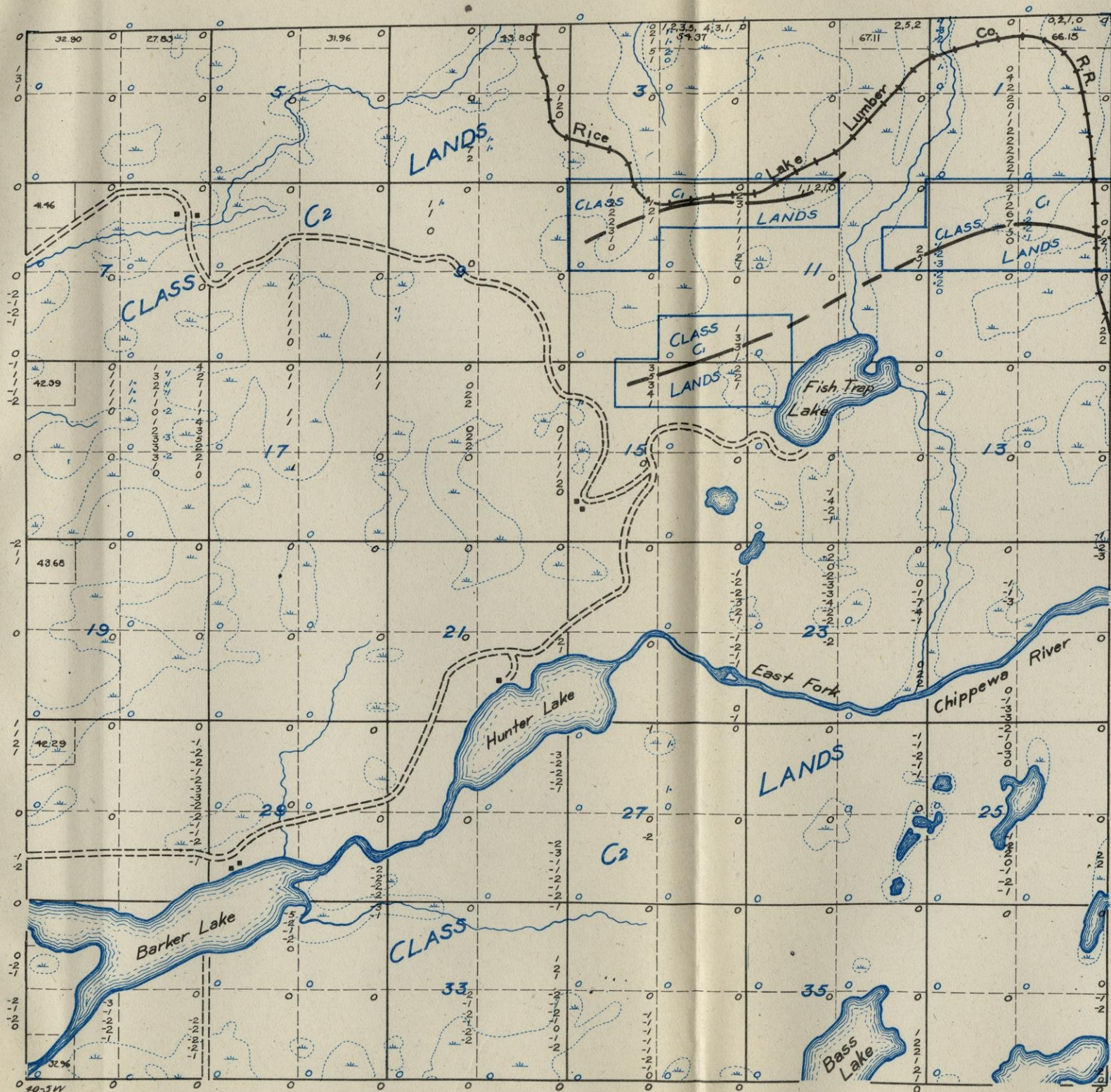

negative readings in the southern part of the township probably result from the presence of igneous rocks.

*Land Classification.*—Certain of the lands on the best defined magnetic lines are placed in class C1, although not among the most favorably situated lands of this class. All others are classed as C2. While, as stated above, it is probable that the areas of negative attraction are underlain by igneous rocks it is not thought advisable to place these lands in the D classification without more definite evidence.

*Exploration.*—Exploration is not recommended in this township unless work elsewhere makes the prospects for finding iron formation appear better. The magnetic lines are rather short and poorly defined but they may mark the locations of iron formations and until some work has been done the territory cannot be condemned.

## TOWNSHIP 40 N., RANGE 6 W.

*Surface Features.*—Most of the township except the southwest corner and that part along the west fork of the Chippewa River has a gently undulating surface and no prominent topographic features. There are a number of shallow depressions occupied by small lakes but the general level of the surface does not show much variation. The Chippewa has a narrow and deep valley. In its upper course it is rapidly flowing and has frequent rapids, but in the south half of the township it widens out to form a long narrow lake-like body of water having scarcely any current. In sections 31, 32, and 33 the ground is rather rugged. Blueberry Lake occupies a deep valley which has every appearance of having been a channel for the Chippewa River in pre-glacial times. A prominent rock cored hill runs east and west along the south line of sections 31 and 32. The profile along the road in the southern row of sections shows the topography rather poorly since the road is of the winding sort that follows the most level ground. However, it gives some idea of the relief of that part of the township.

None of the roads in the township are graded but because of their sandy character they are passable at nearly all times. The original timber was nearly all pine but some hardwood existed in the south central part and a small quantity still remains in sections 32 and 33. A small amount of pine is still standing in the vicinity of the Indian village of Post. Much of this township is in the Chippewa Indian reservation. The only settlers are Indians and consequently agriculture is not of any importance.

*Glacial Drift.*—Most of the township is ground moraine, which has been considerably dissected along the river. West of the Chippewa and south of the Chief River is an extensive pitted outwash plain. The drift in the ground moraine is sand, gravel and boulders with more or less silt, while in the outwash area it is almost entirely sand. There is no information bearing on the depth of the surface except near the southwestern corner where rock outcrops are found. It probably exceeds 100 feet over most of the township.

*General Geology.*—Rock exposures are found at only one point. Along the south line of the S. W.  $\frac{1}{4}$  of section 31 are several small exposures of pink and reddish quartzite composed principally of fine, well cemented grains of sand, which have occasional pebbles of quartz as large as a pea. The rock is identical in character with the

**TOWN 40 N., R. 6W.**

Survey Made in July, 1914

Under the Direction of

W. O. HOTCHKISS, State Geologist

AND  
E. F. BEAN and O. W. WHEELWRIGHT,  
in charge of Field Parties

BY

J. P. GOLDSBERRY, Chief of Party

C. W. HONESS, Asst. Geologist

T. M. LANGLEY, Asst. Geologist

**SYMBOLS AND ABBREVIATIONS.**

The symbols and abbreviations used on this map are explained in Chapter II.

**TOWN AND RANGE LINES.**

In constructing this map the south line of the township was laid off as a true east west line. The other boundary lines were then laid off with the lengths shown on the Land Survey plat. Some of the maps are therefore incorrect in shape but this is necessary because definite facts are lacking. The acreage of part of the lots in the north and west tier of sections is shown to give a check on the distances in these sections.

**LOCATIONS.**

All locations are based on pacing traverses from government land corners. In many cases these were not found and it was necessary to continue the traverse several miles without a check. Locations of certain features may therefore be somewhat wrong. In such cases the feature sought may best be located by its relation to a stream, swamp, lake, or other feature shown on the map.

**PROFILES.**

The locations of the profiles are shown on the map by dashed blue lines with black letters at the ends. Railroad profiles were furnished by the companies and show elevations of the ground rather than track in most cases; others are from road surveys by the State Highway Commission; most of them are hand level lines made by this Survey. Wherever possible the elevations above sea level are given. These elevations vary from 1050 to 1770 feet. A local datum plane was necessarily assumed in some cases. These cases are identifiable by the fact that the base line is always numbered 0.

**LAND CLASSIFICATION.**

This is shown on the map by the blue letters. It is explained in the following township description and at length in chapter V.

**MAGNETIC DATA.**

Dial compass readings are shown in blue figures. Eastward declinations are shown with a dot to the east and westward with a dot to west of the number. Dip needle readings are shown in black. All are positive except those preceded by the negative sign. All readings show deviation of needles from the normal reading of the instrument used. Normal readings are omitted from the map except at each quarter section corner. All abnormal readings are shown.

Traverses were made on lines indicated—usually the N-S section and quarter lines. Dip needle readings were taken each 50 paces, dial compass readings each 100 paces when sun permitted.

Magnetic lines are indicated by heavy black lines, solid where definite and dashed where doubtful.

**CAUTION:** Almost any kind of rock may be the cause of magnetic attraction. Do not fail to read the following description of this township, and also chapter IV., in which the magnetic attractions are discussed.

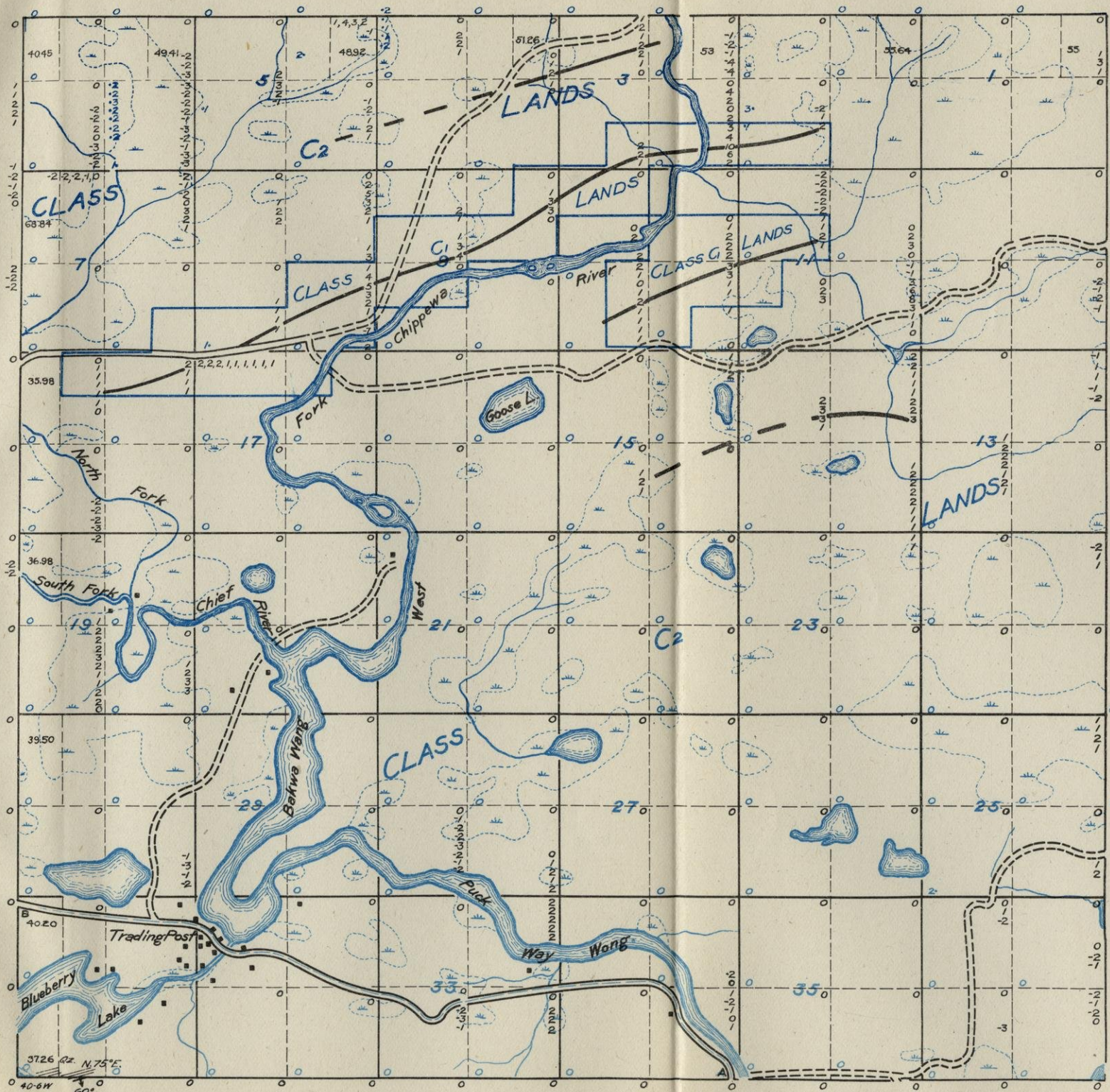

**PROFILE**  
VERTICAL SCALE: 1 space = 20'  
HORIZONTAL SCALE: same as map.

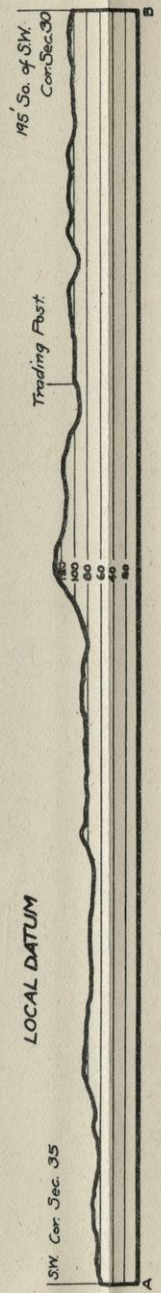

Barron quartzite occurring some ten miles to the southwest. Bedding is here very distinct and the strike is about N. 75° E. and the dip 60° to the south. The most westerly outcrop is very much cross-bedded and dips somewhat more steeply toward the south. Other exposures of this rock are found in sections 5, 6, and 7 of the township to the south where the dip is north at a low angle, and it appears that there is here a small syncline in the quartzite. Indications are that the rock does not extend under the drift in this township for any great distance from the exposures.

*Magnetic Observations.*—A general discussion of magnetic observations and their significance is given in Chapter IV. Distributed irregularly over the township are a number of areas of magnetic attraction which cause both positive and negative readings of the dip needle. Magnetic lines are very poorly defined as a rule but there is a general parallelism in their direction. The line extending from section 2 to section 18 has good characteristics. Probably most of the attraction is caused by sedimentary rocks and it is not improbable that there may be iron formation present.

*Land Classification.*—A discussion of the principles of land classification employed in this work is given in Chapter V. Lands in this township located on the most definite lines of attraction in the northern part are placed in class C1. All others are classed as C2 for lack of information upon which to base a more positive classification.

*Exploration.*—Exploration cannot be strongly recommended unless future developments in the general area indicate that iron formation occurs here. With the information at hand now it appears that the most favorable place is along the line between sections 2 and 18. Much of the work done in exploration for iron ore is wasted because of failure to make intelligent use of the geologic and magnetic data to be obtained by a careful preliminary survey, and because the geologic information given by the drill is not properly used as a guide for further work. The value of careful scientific methods of exploration therefore cannot be too strongly emphasized. If exploration is contemplated in this township the discussion of this subject in chapter VI should be carefully studied.

## TOWNSHIP 40 N., RANGE 7 W.

*Surface Features.*—The topography in the northwestern part of the township is roughly undulating. The remainder is level to gently undulating with much dissection near streams and lakes. There are numerous small lakes. Big Chief River with its northern tributaries form what is locally called the "flowage." These streams are very sluggish and the swamps about them are floating muskegs.

The roads are not well graded, but since the soil is very sandy, they are fairly good most of the year. None of the roads are straight, but wind about so as to secure the easiest grade. Except for small patches the timber has all been cut. Farming has not developed to any extent, there being only a few Indian gardens in the southern part of the township.

*Glacial Drift.*—In the northwestern part is an area of roughly undulating terminal moraine which grades almost imperceptibly into outwash to the east. The topography is rough to the north and west and there are numerous kettles as deep as 50 feet. Ground moraine with gently undulating topography occurs in the southwest, northeast, and in parts of sections 24, 25, 26, 27, 34, and 35. It contains numerous lakes and swamps. The remainder of the township is outwash, deeply pitted near the terminal and stream dissected near the rivers and lakes.

The glacial deposits are sand and gravel with some boulders in the terminal moraine; sand and gravel in the outwash; much sand and gravel, numerous boulders and some silt in the ground moraine.

Since ledge does not come to the surface and well data are lacking, the depth of drift can only be estimated. It is probably over 100 feet in thickness, except in the southwest where the cover may be somewhat thinner.

*General Geology.*—There are no exposures of rock in this township, nor any in the adjoining townships which are of assistance in determining the character of the underlying rock. It is believed that the southwest part of the township may be underlain by patches of the Barron quartzite. Angular blocks of this rock are found west and northwest of Chief Lake indicating that the ledge is not far from the surface at these points, and it seems quite probable that it may extend into this township, but the evidence is not sufficiently conclusive to warrant mapping it. The same formation outcrops very close to the southeast corner of this township but under such structural conditions that it is not believed to extend

### TOWN 40 N., R. 7W.

Survey Made in August, 1914

Under the Direction of  
**W. O. HOTCHKISS**, State Geologist  
AND  
**E. F. BEAN** and **O. W. WHEELWRIGHT**,  
in charge of Field Parties

BY  
**T. M. BRODERICK**, Chief of Party  
**H. N. EIDEMILLER**, Asst. Geologist  
**F. R. PRETYMAN**, Asst. Geologist

#### SYMBOLS AND ABBREVIATIONS.

The symbols and abbreviations used on this map are explained in Chapter II.

#### TOWN AND RANGE LINES.

In constructing this map the south line of the township was laid off as a true east west line. The other boundary lines were then laid off with the lengths shown on the Land Survey plat. Some of the maps are therefore incorrect in shape but this is necessary because definite facts are lacking. The acreage of part of the lots in the north and west tier of sections is shown to give a check on the distances in these sections.

#### LOCATIONS.

All locations are based on pacing traverses from government land corners. In many cases these were not found and it was necessary to continue the traverse several miles without a check. Locations of certain features may therefore be somewhat wrong. In such cases the feature sought may best be located by its relation to a stream, swamp, lake, or other feature shown on the map.

#### PROFILES.

The locations of the profiles are shown on the map by dashed blue lines with black letters at the ends. Railroad profiles were furnished by the companies and show elevations of the ground rather than track in most cases; others are from road surveys by the State Highway Commission; most of them are hand level lines made by this Survey. Wherever possible the elevations above sea level are given. These elevations vary from 1050 to 1770 feet. A local datum plane was necessarily assumed in some cases. These cases are identifiable by the fact that the base line is always numbered 0.

#### LAND CLASSIFICATION.

This is shown on the map by the blue letters. It is explained in the following township description and at length in chapter V.

#### MAGNETIC DATA.

Dial compass readings are shown in blue figures. Eastward declinations are shown with a dot to the east and westward with a dot to west of the number. Dip needle readings are shown in black. All are positive except those preceded by the negative sign. All readings show deviation of needles from the normal reading of the instrument used. Normal readings are omitted from the map except at each quarter section corner. All abnormal readings are shown.

Traverses were made on lines indicated—usually the N-S section and quarter lines. Dip needle readings were taken each 50 paces, dial compass readings each 100 paces when sun permitted.

Magnetic lines are indicated by heavy black lines, solid where definite and dashed where doubtful.

**CAUTION:** Almost any kind of rock may be the cause of magnetic attraction. Do not fail to read the following description of this township, and also chapter IV., in which the magnetic attractions are discussed.

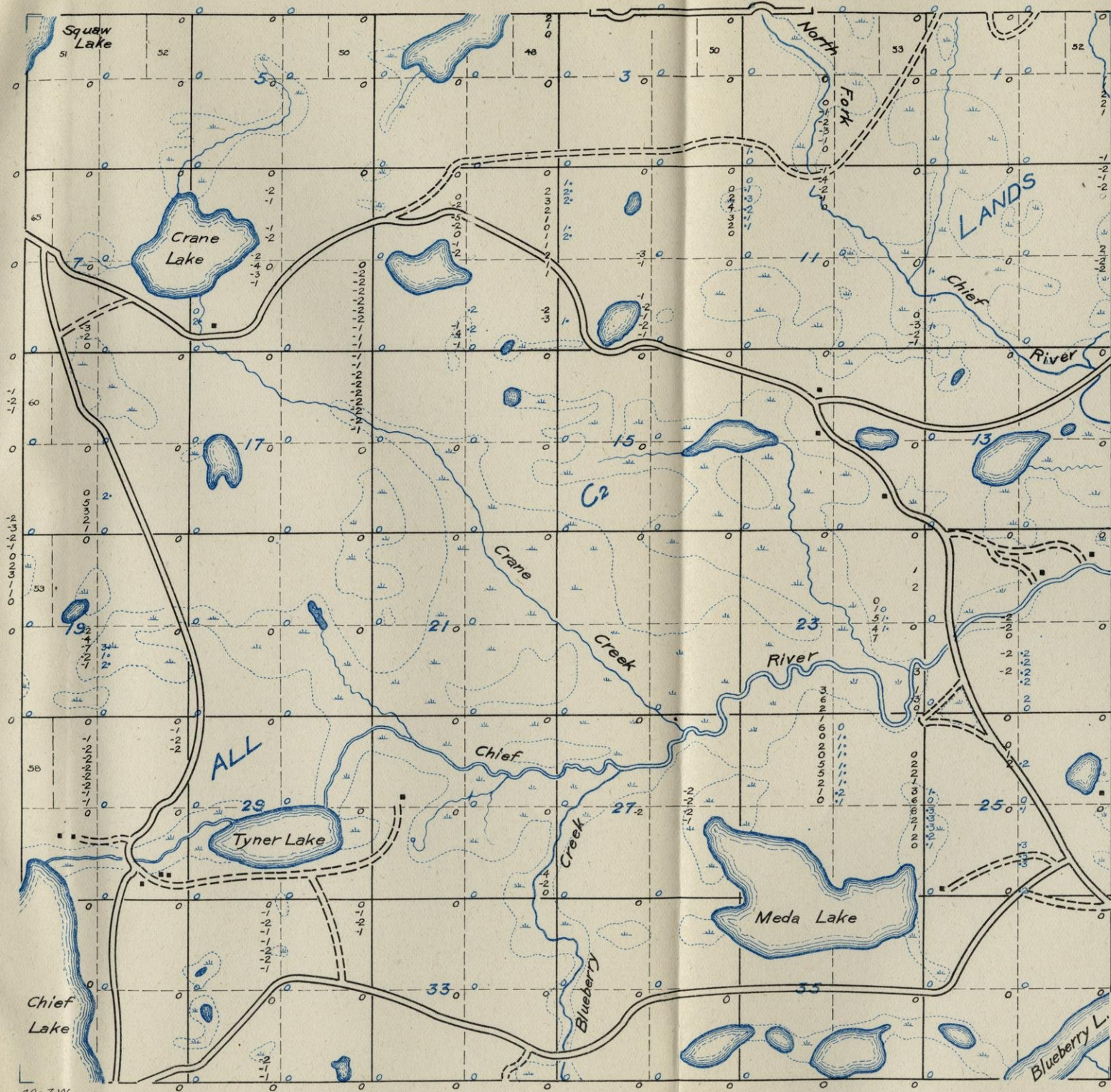



across the line. The only evidence bearing on the character of the older rocks is that obtained from the magnetic work. This is inconclusive but suggests that both igneous rocks and rocks of the Huronian series are present as indicated on the map, plate I.

*Magnetic Observations.*—A general discussion of magnetic observations and their significance is given in Chapter IV. Irregular attractions both positive and negative in character are distributed over the township in places indicated on the map. They do not lie in well defined lines, although there is a suggestion of a general northeast and southwest trend, which is believed to indicate structural lines. The cause of these attractions is not apparent, but it is believed that the negative readings are caused in large part by magnetic igneous rock.

*Land Classification.*—A general discussion of the principles of land classification employed in this work is given in Chapter V. All lands in this township are placed in class C2 for the reason that there is nothing to indicate definitely or even strongly suggest the presence of iron formation but the possibility of its existence must not be overlooked.

*Exploration.*—Exploration for iron ore in this township cannot be recommended with the information at hand.

## TOWNSHIP 40 N., RANGE 8 W.

*Surface Features.*—The northwestern portion of this township and parts of sections 12, 13, 14, 22, 23, and 24 are roughly undulating. The southern part is gently undulating with many small swamps in the depressions. Grindstone Lake and Lac Court Oreilles occupy a large part of the southwest part of the township. The remainder is a sandy plain. Profile A-B is typical of the sandy plain which is, in general, very level. There are minor undulations and occasional depressions like the one north of the center of section 28 but the tops of the hills even here rise to a remarkably uniform height. The roads are not graded, but being sandy are not bad even in wet weather. Nearly all timber of value has been cut. Agriculture is of no importance.

*Glacial Drift.*—North of Grindstone Lake is an area of roughly undulating terminal moraine in which small lakes and swamps occupy the depressions. In parts of sections 12, 13, 14, 22, 23, and 24 is another area of terminal. In the southeast is an area of gently undulating ground moraine. The remainder of the township is outwash, level over large areas, but pitted and stream dissected in others. The northeast-southwest valley extending through sections 10, 11, 15, 21, and 22 was cut by a much larger stream than the one which now occupies it. This valley is 200 or more paces in width and 25 to 30 feet in depth. The northeast arm of Lac Court Oreilles seems to be a continuation of this valley.

The glacial deposits are sand and gravel with numerous boulders in the terminal moraine; much sand, some silt, and boulders in the ground moraine; much sand and a little silt in the outwash.

The numerous angular boulders in sections 12, 26, and 17 seem to indicate a thin covering of drift. Over most of the township the drift cover is probably rather heavy.

*General Geology.*—There are no exposures of rock in this township, but in the north half of section 26 numerous angular boulders of quartzite similar to the Barron formation indicate that this is undoubtedly the bedrock at that point. It is not possible to state just how extensive this formation is but it probably underlies several sections in the southeastern part of the township. Some boulders were found as far north as section 12 and it is possible that nearly the entire eastern half may be underlain by this formation. Northeast of Grindstone Lake the presence of numerous blocks of sandstone is a strong indication that part of the town-

TOWN 40 N., R. 8W.

Survey Made in July, 1914

Under the Direction of  
W. O. HOTCHKISS, State Geologist

AND  
E. F. BEAN and O. W. WHEELWRIGHT,  
in charge of Field Parties

BY  
L. J. YOUNGS, Chief of Party  
H. N. EIDEMILLER, Asst. Geologist  
F. R. PRETYMAN, Asst. Geologist

SYMBOLS AND ABBREVIATIONS.

The symbols and abbreviations used on this map are explained in Chapter II.

TOWN AND RANGE LINES.

In constructing this map the south line of the township was laid off as a true east west line. The other boundary lines were then laid off with the lengths shown on the Land Survey plat. Some of the maps are therefore incorrect in shape but this is necessary because definite facts are lacking. The acreage of part of the lots in the north and west tier of sections is shown to give a check on the distances in these sections.

LOCATIONS.

All locations are based on pacing traverses from government land corners. In many cases these were not found and it was necessary to continue the traverse several miles without a check. Locations of certain features may therefore be somewhat wrong. In such cases the feature sought may best be located by its relation to a stream, swamp, lake, or other feature shown on the map.

PROFILES.

The locations of the profiles are shown on the map by dashed blue lines with black letters at the ends. Railroad profiles were furnished by the companies and show elevations of the ground rather than track in most cases; others are from road surveys by the State Highway Commission; most of them are hand level lines made by this Survey. Wherever possible the elevations above sea level are given. These elevations vary from 1050 to 1770 feet. A local datum plane was necessarily assumed in some cases. These cases are identifiable by the fact that the base line is always numbered 0.

LAND CLASSIFICATION.

This is shown on the map by the blue letters. It is explained in the following township description and at length in chapter V.

MAGNETIC DATA.

Dial compass readings are shown in blue figures. Eastward declinations are shown with a dot to the east and westward with a dot to west of the number. Dip needle readings are shown in black. All are positive except those preceded by the negative sign. All readings show deviation of needles from the normal reading of the instrument used. Normal readings are omitted from the map except at each quarter section corner. All abnormal readings are shown.

Traverses were made on lines indicated—usually the N-S section and quarter lines. Dip needle readings were taken each 50 paces, dial compass readings each 100 paces when sun permitted.

Magnetic lines are indicated by heavy black lines, solid where definite and dashed where doubtful.

CAUTION: Almost any kind of rock may be the cause of magnetic attraction. Do not fail to read the following description of this township, and also chapter IV., in which the magnetic attractions are discussed.

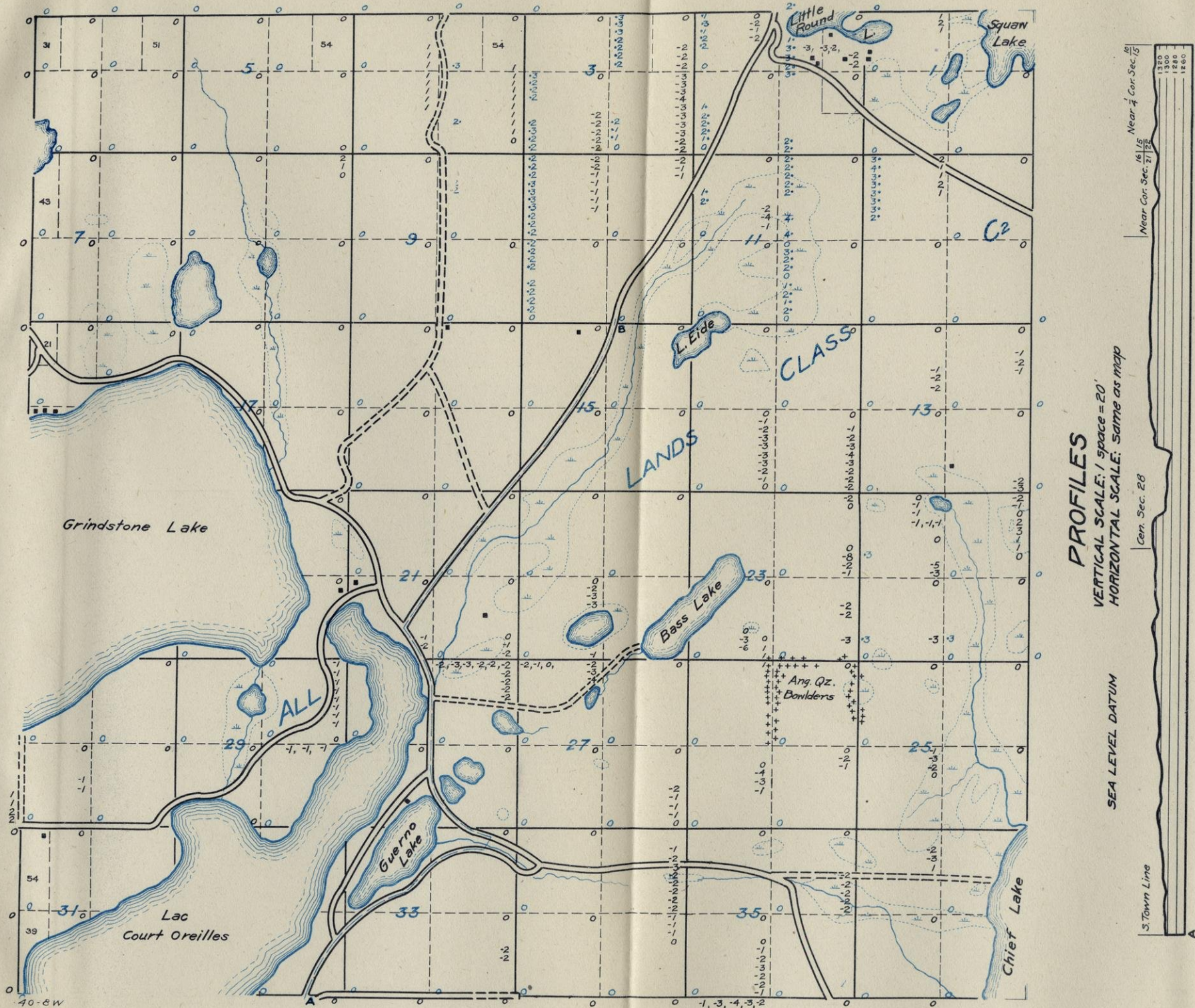

PROFILES

VERTICAL SCALE: 1 space = 20'

HORIZONTAL SCALE: same as map

SEA LEVEL DATUM



ship is underlain by this rock. Of the older rocks beneath these nothing is known. What is believed to be a magnetic iron formation in T. 41-7 W. strikes toward the northwestern part of this township so this is considered to be a Huronian area. Evidence from magnetic work suggests igneous rocks in the remainder of the township.

*Magnetic Observations.*—For a general discussion of magnetic observations and their significance the reader is referred to Chapter IV. Numerous small areas and indefinite lines of attraction usually negative in character are found widely distributed over the township. The attraction is seldom more than  $3^{\circ}$  but in a few instances reaches as much as  $6^{\circ}$  or  $8^{\circ}$  below the normal of the needle. Positive attractions as high as  $3^{\circ}$  were also obtained. While mild deflections of the dial compass were found, they do not indicate the presence of well defined lines of attraction. The significance of such attractions is not readily understood. In adjoining townships to the northeast strong magnetic attraction is undoubtedly caused by a highly magnetic formation which occurs in position and bowlders of this material may be common in the drift in the township under discussion. Irregular attractions of this type are usually considered as being the result of the presence of igneous rocks, but it may be possible that in this case it may be due in a large measure at least, to bowlders in the drift. The positive attractions in sections 4 and 8 may mark the extension of the positive line in T. 41-7 W. and T. 41-8 W. and in the event of the discovery of an iron formation in these townships some more detailed dip needle work should be done here.

*Land Classification.*—For a general discussion of the principles of land classification employed in this work the reader is referred to Chapter V. All lands in this township are placed in class C2. Those in the region of the positive attractions in sections 4 and 8 are, however, considered among the most favorable lands of this class.

*Exploration.*—Exploration in this township should await the results of work in T. 41-7 W. and T. 41-8 W. If a productive iron formation is discovered there it can probably be traced into this township.

## TOWNSHIP 40 N., RANGE 9 W.

*Surface Features.*—The southeastern part of this township is an area of gently undulating topography. Grindstone, Court Oreilles and smaller lakes occupy most of this part. In the northwest is a broad plain through which the Namakagon River flows. Nearly all the remaining part of the township is roughly undulating with numerous kettles containing lakes or swamps. The accompanying profile gives a very good idea of the topography of the township. By adding 1160 feet to the elevations given, they may be reduced to sea level datum. For a mile south from the north township line the topography is flat. From there southward the country is very rugged and in section 33 rises to a height of 260 feet above the plain in the northern part of the township. From this point there is a steep slope southward.

The roads in the plain are fairly good. Nearly all the timber has been cut. There are some good farms in the southern and in the northern parts of the area. The township was originally timbered with pine which has been almost entirely removed.

*Glacial Drift.*—In the northwestern part is an area of outwash which is deeply pitted along its southern border. In the southeast is a ground moraine area. The remainder of the township is a terminal moraine with pronounced knob and kettle topography. The glacial deposits are largely sand in the outwash; sand, gravel, silt and boulders in the terminal; sand, silt and boulders in the ground moraine.

The thickness of drift is not definitely known, but in the terminal moraine it is probably great, as no rock is known to outcrop and it rises to elevations as great as 260 feet above the plain in the north. The drift cover in the northwest and southeast parts of the area is probably considerably thinner.

*General Geology.*—No rock exposures were found in this township and no wells reach the ledge and consequently nothing is known of the character of the underlying rock. There is good reason for believing that sandstone will be found beneath the surface. From the general location with reference to townships to the northeast which offer more information, it appears that the chance for the occurrence of Huronian rocks and possibly iron formation is good.

TOWN 40 N., R. 9W.

Survey Made in July, 1914

Under the Direction of  
W. O. HOTCHKISS, State Geologist  
AND  
E. F. BEAN and O. W. WHEELWRIGHT,  
in charge of Field Parties  
BY

T. M. BRODERICK, Chief of Party  
H. D. WAKEFIELD, Asst. Geologist  
R. S. TARR, Asst. Geologist

**SYMBOLS AND ABBREVIATIONS.**  
The symbols and abbreviations used on this map are explained in Chapter II.

**TOWN AND RANGE LINES.**  
In constructing this map the south line of the township was laid off as a true east west line. The other boundary lines were then laid off with the lengths shown on the Land Survey plat. Some of the maps are therefore incorrect in shape but this is necessary because definite facts are lacking. The acreage of part of the lots in the north and west tier of sections is shown to give a check on the distances in these sections.

**LOCATIONS.**  
All locations are based on pacing traverses from government land corners. In many cases these were not found and it was necessary to continue the traverse several miles without a check. Locations of certain features may therefore be somewhat wrong. In such cases the feature sought may best be located by its relation to a stream, swamp, lake, or other feature shown on the map.

**PROFILES.**  
The locations of the profiles are shown on the map by dashed blue lines with black letters at the ends. Railroad profiles were furnished by the companies and show elevations of the ground rather than track in most cases; others are from road surveys by the State Highway Commission; most of them are hand level lines made by this Survey. Wherever possible the elevations above sea level are given. These elevations vary from 1050 to 1770 feet. A local datum plane was necessarily assumed in some cases. These cases are identifiable by the fact that the base line is always numbered 0.

**LAND CLASSIFICATION.**  
This is shown on the map by the blue letters. It is explained in the following township description and at length in chapter V.

**MAGNETIC DATA.**  
Dial compass readings are shown in blue figures. Eastward declinations are shown with a dot to the east and westward with a dot to west of the number. Dip needle readings are shown in black. All are positive except those preceded by the negative sign. All readings show deviation of needles from the normal reading of the instrument used. Normal readings are omitted from the map except at each quarter section corner. All abnormal readings are shown.

Traverses were made on lines indicated—usually the N-S section and quarter lines. Dip needle readings were taken each 50 paces, dial compass readings each 100 paces when sun permitted.

Magnetic lines are indicated by heavy black lines, solid where definite and dashed where doubtful.

**CAUTION:** Almost any kind of rock may be the cause of magnetic attraction. Do not fail to read the following description of this township, and also chapter IV., in which the magnetic attractions are discussed.

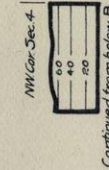
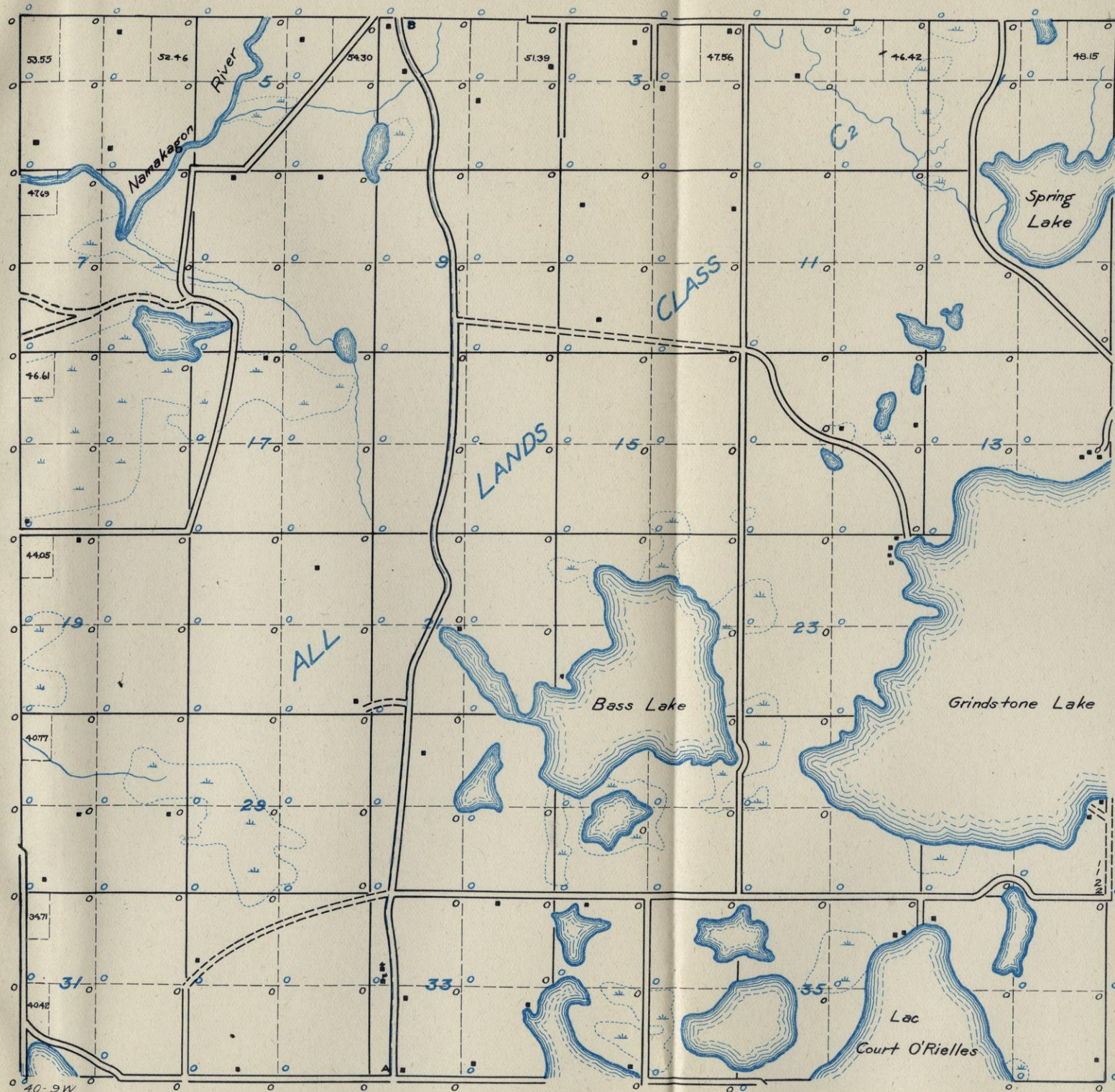

**PROFILES**  
VERTICAL SCALE: 1 space = 20'  
HORIZONTAL SCALE: same as map  
Sec. Line bet. Secs. 16-21

LOCAL DATUM

SW Cor. Sec. 33

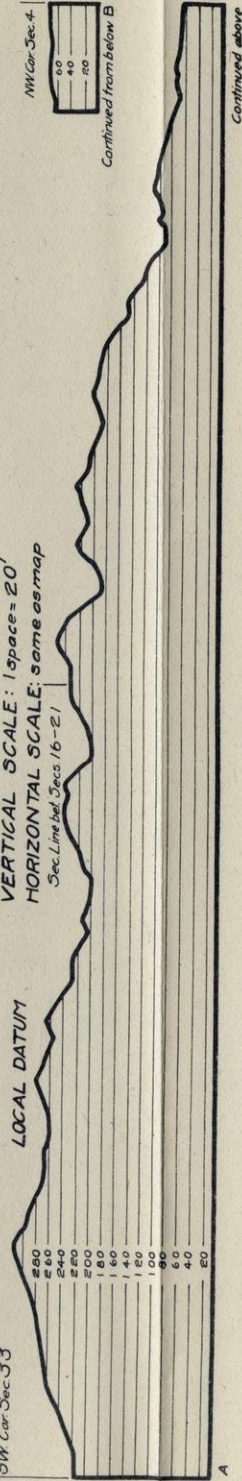

*Magnetic Observations.*—No **abnormal** attractions were found.

*Land Classification.*—The **principles** of land classification employed in this work are discussed in Chapter V. All lands in this township are placed in class C2.

*Exploration.*—Exploration in this township is not recommended at present. Future work to the northeast may show that there is an iron formation trending toward this township which would change the situation. Regarding this subject the reader is referred to the report on T. 41-7 W. and to chapter VI which discusses exploration in a general way.

## TOWNSHIP 40 N., RANGE 10 W.

*Surface Features.*—The Namakagon River, bordered by a plain, occupies the northeast and northwest parts of this township. Extending southwest from section 13 to section 31 is a flat plain, very swampy for the most part, but well drained in the southwest. Outside of these areas the topography is gently to roughly undulating. Profiles A-B and E-F show the roughly undulating topography with hills rising in some places to a height of 80 feet above the plain. In the more level parts the roads are fairly good. Most all of the timber has been cut. Where the topographic conditions are favorable, farming is developing.

*Glacial Drift.*—An outwash plain extends across the northwest and northeast corners of the township. From the northeast corner an outwash plain extends southwest through the township. The Namakagon River may at some time have flowed through this plain. Outside the area of outwash the township is terminal moraine varying from gently to roughly undulating.

The glacial deposits are sand, gravel, some silt and numerous bowlders in the terminal moraine; much sand and some silt in the outwash.

The thickness of the drift in this township is not definitely known as no wells are reported to reach ledge. The deepest well is 72 feet in the southeastern corner of section 6. It is probable that in the areas of outwash the drift covering averages at least 75 feet in thickness, and that in the terminal moraine the thickness is somewhat greater.

*General Geology.*—There is no information regarding the character of the underlying rock in this township. From information obtained in adjoining townships it is probable that sandstone overlies the older rocks, but it is impossible to state what the character of these older rocks is.

*Magnetic Observations.*—No abnormal attractions were obtained in this township.

*Land Classification.*—The principles of land classification employed in this work are discussed in Chapter V. Because of lack of information all lands in this township are placed in class C2.

*Exploration.*—Exploration in this township is not recommended. It cannot be stated positively that iron formation is absent but if it is present it gives no indication of the fact.



TOWN 40 N., R. 10W.

Survey Made in August, 1914

Under the Direction of

W. O. HOTCHKISS, State Geologist

AND

E. F. BEAN and O. W. WHEELWRIGHT,  
in charge of Field Parties

BY

H. D. WAKEFIELD, Chief of Party

R. S. TARR, Asst. Geologist

R. R. THOMPSON, Asst. Geologist

E. A. KRONQUIST, Asst. Geologist

SYMBOLS AND ABBREVIATIONS.

The symbols and abbreviations used on this map are explained in Chapter II.

TOWN AND RANGE LINES.

In constructing this map the south line of the township was laid off as a true east west line. The other boundary lines were then laid off with the lengths shown on the Land Survey plat. Some of the maps are therefore incorrect in shape but this is necessary because definite facts are lacking. The acreage of part of the lots in the north and west tier of sections is shown to give a check on the distances in these sections.

LOCATIONS.

All locations are based on pacing traverses from government land corners. In many cases these were not found and it was necessary to continue the traverse several miles without a check. Locations of certain features may therefore be somewhat wrong. In such cases the feature sought may best be located by its relation to a stream, swamp, lake, or other feature shown on the map.

PROFILES.

The locations of the profiles are shown on the map by dashed blue lines with black letters at the ends. Railroad profiles were furnished by the companies and show elevations of the ground rather than track in most cases; others are from road surveys by the State Highway Commission: most of them are hand level lines made by this Survey. Wherever possible the elevations above sea level are given. These elevations vary from 1050 to 1770 feet. A local datum plane was necessarily assumed in some cases. These cases are identifiable by the fact that the base line is always numbered 0.

LAND CLASSIFICATION.

This is shown on the map by the blue letters. It is explained in the following township description and at length in chapter V.

MAGNETIC DATA.

Dial compass readings are shown in blue figures. Eastward declinations are shown with a dot to the east and westward with a dot to west of the number. Dip needle readings are shown in black. All are positive except those preceded by the negative sign. All readings show deviation of needles from the normal reading of the instrument used. Normal readings are omitted from the map except at each quarter section corner. All abnormal readings are shown.

Traverses were made on lines indicated—usually the N-S section and quarter lines. Dip needle readings were taken each 50 paces, dial compass readings each 100 paces when sun permitted.

Magnetic lines are indicated by heavy black lines, solid where definite and dashed where doubtful.

CAUTION: Almost any kind of rock may be the cause of magnetic attraction. Do not fail to read the following description of this township, and also chapter IV., in which the magnetic attractions are discussed.

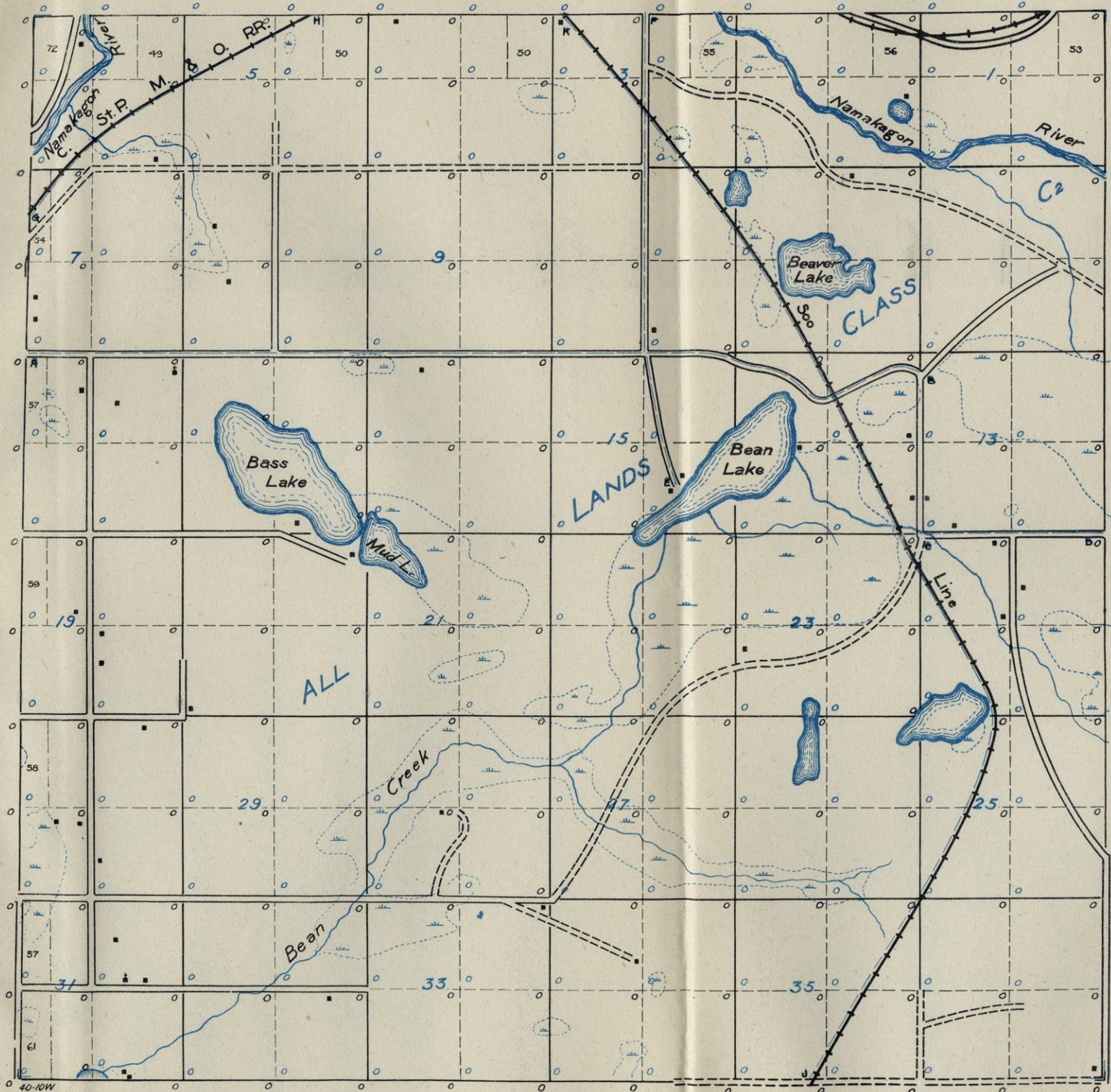

PROFILES  
VERTICAL SCALE: 1 space = 20'  
HORIZONTAL SCALE: same as map.

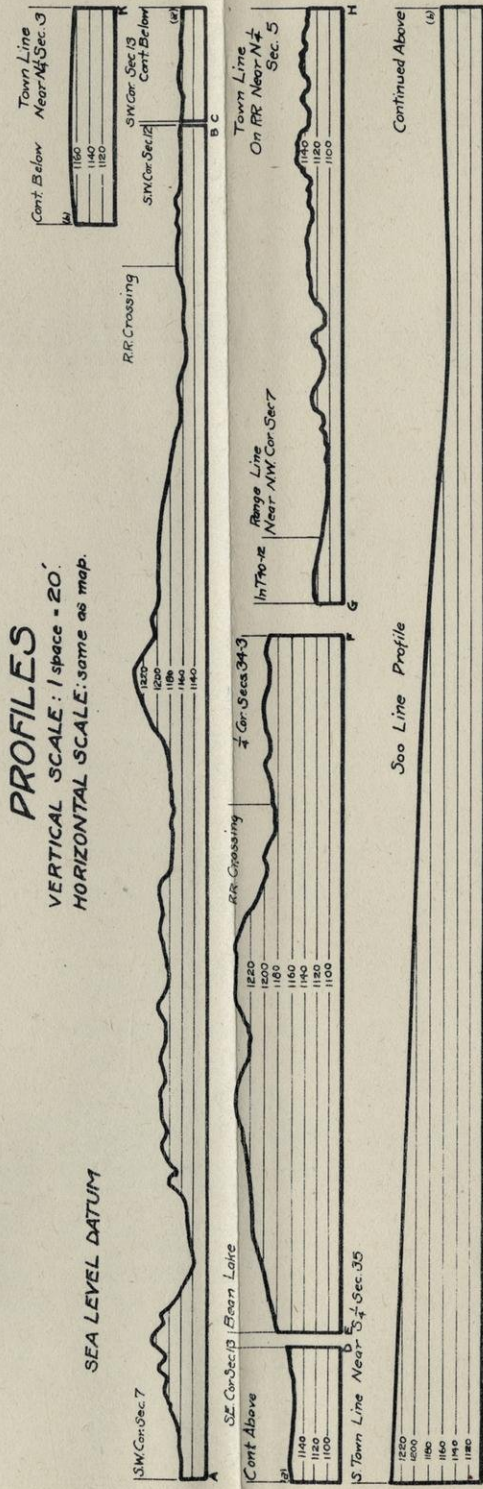

SEA LEVEL DATUM

## TOWNSHIP 40 N., RANGE 11 W.

*Surface Features.*—The Namakagon River meanders over a broad plain extending northeast-southwest through the township. Bear Creek and Spring Creek flow through similar plains. These plains are bordered by higher areas of roughly undulating topography.

The accompanying profile E-F shows the flat plain south of Bean Creek and the rougher country to the north in sections 28, 22, and 23. Similar features are shown in the profile A-B except that the plain in sections 12 and 13 is dissected by streams tributary to the Namakagon. Profile C-D shows the level plain south and west of Spring Lake and the rugged topography in sections 23, 24, and 13. Except for the fact that they are extremely sandy, the roads are fairly good. The valuable timber has all been cut. Southeast of Namakagon River the country is well settled.

*Glacial Drift.*—In the northwest part of the township is a terminal moraine area which reaches its maximum elevation near the northwest corner of section 18,—nearly 100 feet above the outwash plain to the south. Along the southeastern edge of this terminal moraine area the outwash is pitted. In sections 13, 24, and 25 a terminal moraine rises from 40 to 60 feet above the outwash plain to the west. The topography here is characterized by a series of ridges trending roughly north and south with minor sags and swells between them. A third area of terminal is found in sections 22, 23, and 28. All the remainder is outwash, which is quite level except for stream dissection in the northeastern part of the township.

The glacial deposits are chiefly sand with some silt and numerous boulders in the terminal moraine; and mostly sand with some gravel in the outwash.

Wells are comparatively shallow in the outwash plain. Southeast of the center of section 7 a well was drilled to 160 feet without reaching ledge. Since no wells reach ledge in this township and there are no rock outcrops, the thickness can only be estimated. The drift cover in the outwash plain probably averages more than 75 feet in thickness. In the ground and terminal moraine the thickness is probably greater.

*General Geology.*—There is no information regarding the character of the underlying rock in this township. From general knowledge of the area it is believed that sandstone will be found beneath the drift, but there is no evidence on which this can be stated positively.

*Magnetic Observations.*—No abnormal magnetic readings were obtained.

*Land Classification.*—For a general discussion of the principles of land classification the reader is referred to Chapter V. Because of the lack of information all lands in this township are placed in class C2.

*Exploration.*—The entire lack of information regarding the geological formations in this township makes it impossible either to advise exploration or to condemn the lands as having no possibilities for the discovery of iron ore.

TOWN 40 N., R. 1 W.

Survey Made in July, 1914

Under the Direction of  
W. O. HOTCHKISS, State Geologist

AND  
E. F. BEAN and O. W. WHEELWRIGHT,  
in charge of Field Parties

BY  
W. L. DOBIE, Chief of Party

O. W. POTTER, Asst. Geologist

D. G. THOMPSON, Asst. Geologist

SYMBOLS AND ABBREVIATIONS.

The symbols and abbreviations used on this map are explained in Chapter II.

TOWN AND RANGE LINES.

In constructing this map the south line of the township was laid off as a true east west line. The other boundary lines were then laid off with the lengths shown on the Land Survey plat. Some of the maps are therefore incorrect in shape but this is necessary because definite facts are lacking. The acreage of part of the lots in the north and west tier of sections is shown to give a check on the distances in these sections.

LOCATIONS.

All locations are based on pacing traverses from government land corners. In many cases these were not found and it was necessary to continue the traverse several miles without a check. Locations of certain features may therefore be somewhat wrong. In such cases the feature sought may best be located by its relation to a stream, swamp, lake, or other feature shown on the map.

PROFILES.

The locations of the profiles are shown on the map by dashed blue lines with black letters at the ends. Railroad profiles were furnished by the companies and show elevations of the ground rather than track in most cases; others are from road surveys by the State Highway Commission; most of them are hand level lines made by this Survey. Wherever possible the elevations above sea level are given. These elevations vary from 1050 to 1770 feet. A local datum plane was necessarily assumed in some cases. These cases are identifiable by the fact that the base line is always numbered 0.

LAND CLASSIFICATION.

This is shown on the map by the blue letters. It is explained in the following township description and at length in chapter V.

MAGNETIC DATA.

Dial compass readings are shown in blue figures. Eastward declinations are shown with a dot to the east and westward with a dot to west of the number. Dip needle readings are shown in black. All are positive except those preceded by the negative sign. All readings show deviation of needles from the normal reading of the instrument used. Normal readings are omitted from the map except at each quarter section corner. All abnormal readings are shown.

Traverses were made on lines indicated—usually the N-S section and quarter lines. Dip needle readings were taken each 50 paces, dial compass readings each 100 paces when sun permitted.

Magnetic lines are indicated by heavy black lines, solid where definite and dashed where doubtful.

CAUTION: Almost any kind of rock may be the cause of magnetic attraction. Do not fail to read the following description of this township, and also chapter IV., in which the magnetic attractions are discussed.

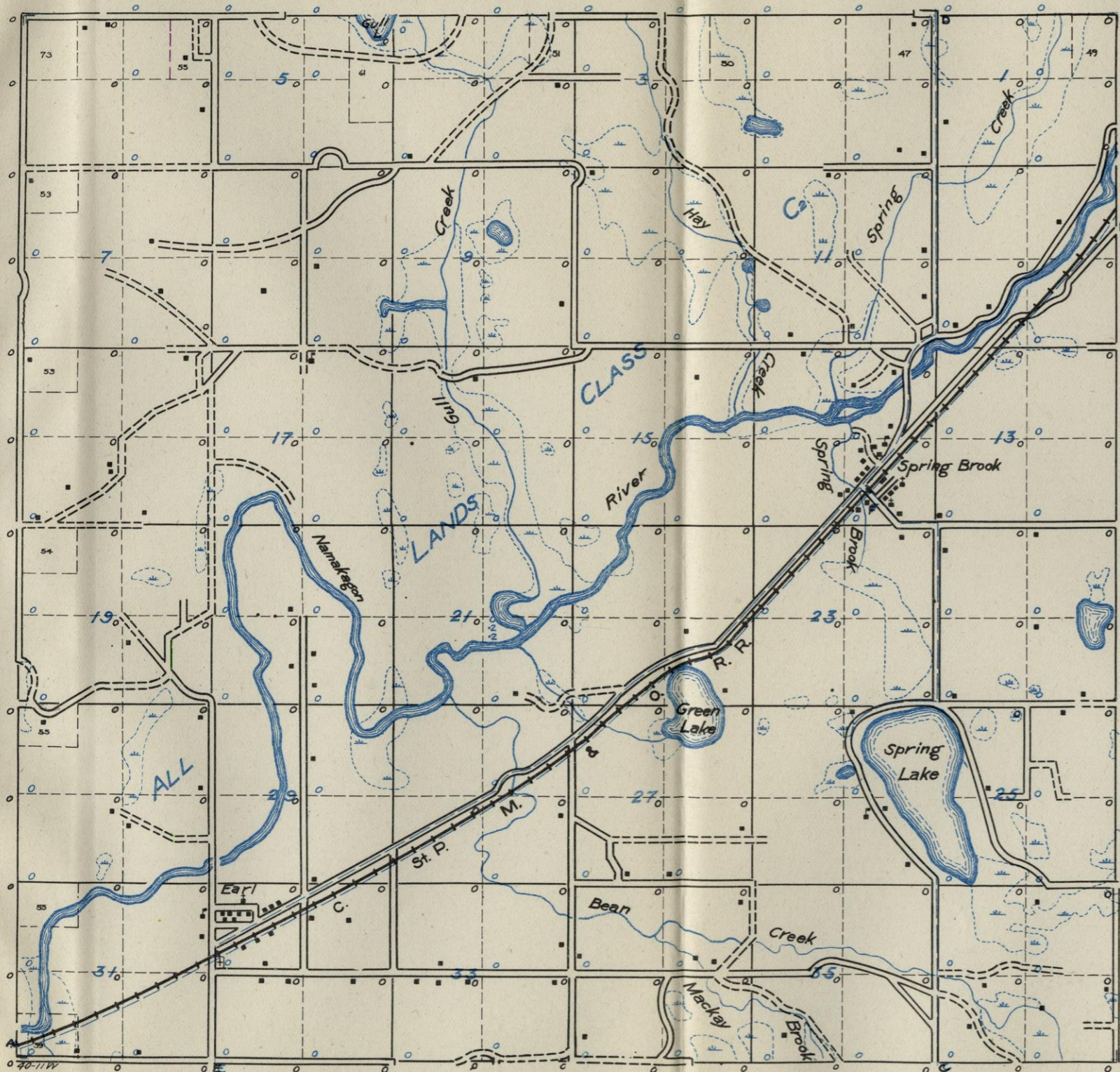

PROFILES

VERTICAL SCALE: 1 space = 20'  
HORIZONTAL SCALE: same as map

SEA LEVEL DATUM

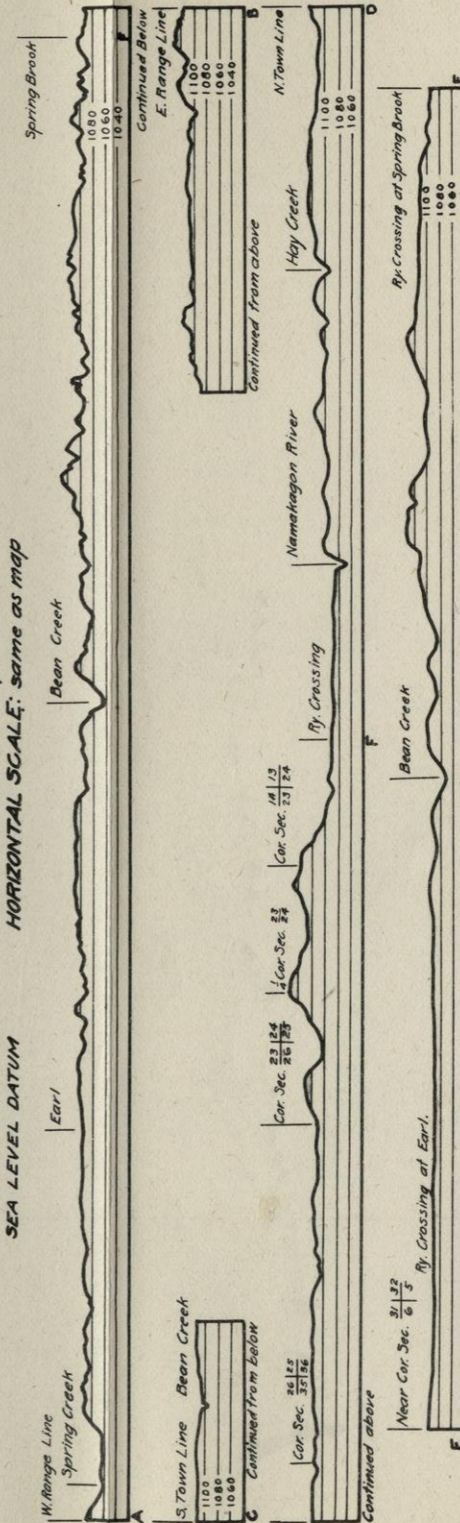

## TOWNSHIP 41 N., RANGE 1 W.

*Surface Features.*—The topography of this township is usually gently rolling, with a very few flat areas as along Butternut Creek just north and south of the village of Butternut and in sections 13 and 14. West of Butternut Lake is a prominent ridge which extends northeast into section 12 and branches to the north and south near the east range line. Another rough area is found extending in an irregular fashion from section 6 to the east side of section 20. A large swamp covers most of sections 5, 8, and 17. The north end of Butternut Lake, located in sections 32 and 33, has beautiful clean-cut shore lines and is a favorite summer resort. The railroad profiles show the flat plain near Butternut and the marked rise of the ridge to the north, as well as the general rolling nature of the topography.

Very little timber remains in this township and it is unusually well settled for this section of the state. Roads are numerous and usually very good, many of them having been covered with gravel.

*Glacial Drift.*—A narrow ridge of terminal moraine is found on the east side of sections 1 and 12 extending through the center of section 13 to the south quarter post of section 24. Connecting with this in the southwest quarter of section 12 is a narrow ridge of terminal moraine,  $\frac{1}{4}$  to  $\frac{1}{2}$  mile wide, which runs west to the south quarter post of section 11, then south into the S. W.  $\frac{1}{4}$  of section 14, and N. W. to the south quarter post of section 10, from which point it continues in a nearly straight line to the township line just west of Butternut Lake. Throughout most of its extent it presents characteristic terminal moraine topography. The ridge of high ground extending from section 6 in an irregular manner to section 20 also presents a typical terminal moraine topography. Outwash occurs in a strip about  $\frac{1}{2}$  mile wide along Butternut Creek between sections 15 and 33 and over a small area in the north half of section 8. Elsewhere the glacial deposits are ground moraine. Very flat ground moraine is found in the west half of section 13 and in the east part of section 14. The glacial deposits consist principally of silt, gravel, sand and boulders in the terminal and ground moraines. The gravel is usually covered with a few feet of silt, except on the tops of a few hills. Large boulders are very common. The outwash along Butternut Creek is principally sand with some small gravel in it.

The thickness of the drift is not known since no wells penetrated to the bed rock. There are a large number of wells in the township but few of them are deep. One at the center of section 33 is 117

feet deep and at the northwest corner of 26 is one 91 feet. Several are over 60 feet in depth. The drift will probably prove to be over 100 feet deep in most parts of the township.

*General Geology.*—No exposures of rock are found in this township but in T. 41-1 E. some test pits have been sunk into iron formation and sedimentary schists which strike to the southwest and it is thought quite likely that rocks of this kind will be found underlying this township. Huronian rocks probably underlie all except the extreme western part where it is believed that there is granite.

*Magnetic Observations.*—A general discussion of magnetic observations and their significance is given in Chapter IV. Extending east and southwest of the village of Butternut is a line of very strong attraction, where dip needle and dial deflections of unusual magnitude are found. In places the dip needle is deflected as much as  $85^{\circ}$  and a dial is drawn as much as  $127^{\circ}$  from normal. The line is fairly regular in character and is such as to lead to the belief that it is caused by an iron formation. It is continuous for some distance in the township to the east, and although it does not lead directly into the test pits in iron formation, it is thought to indicate almost certainly the presence of this kind of rock. Another strong magnetic line is found extending east and west through the center of sections 9 and 10. Very strong attractions are also obtained here and it is thought that this line indicates the presence of an iron formation. A milder belt of attraction extends across the north half of sections 17 and 18. In this instance the dip needle did not show readings of more than  $7^{\circ}$ , but the line is clean-cut and since it is nearly along the strike of the one in sections 9 and 10 it is thought to be due to the same type of rock. Strong attraction is obtained in the extreme northeast corner of the township. The maximum of this line is in the townships to the north and east. Low readings of the dip needle were obtained in a number of other spots, but no other well defined lines were found. It will be noticed that the line stops very abruptly west of Butternut, due possibly to the presence of intrusive granite.

*Land Classification.*—The principles of land classification employed in this work are discussed in Chapter V. The lands immediately on the well-defined magnetic lines are placed in class B, since it is reasonably certain that iron formation is the cause of this attraction. All other lands are placed in class C2. The evidence for the presence of granite is not sufficiently conclusive to warrant classing these as D lands.

TOWN 41 N., R. 1 W.

Survey Made in September, 1914

Under the Direction of

W. O. HOTCHKISS, State Geologist

AND

E. F. BEAN and O. W. WHEELWRIGHT,  
in charge of Field Parties

BY

F. B. PLUMMER, Chief of Party

R. N. HUNT, Asst. Geologist

C. S. GWINN, Asst. Geologist

SYMBOLS AND ABBREVIATIONS.

The symbols and abbreviations used on this map are explained in Chapter II.

TOWN AND RANGE LINES.

In constructing this map the south line of the township was laid off as a true east west line. The other boundary lines were then laid off with the lengths shown on the Land Survey plat. Some of the maps are therefore incorrect in shape but this is necessary because definite facts are lacking. The acreage of part of the lots in the north and west tier of sections is shown to give a check on the distances in these sections.

LOCATIONS.

All locations are based on pacing traverses from government land corners. In many cases these were not found and it was necessary to continue the traverse several miles without a check. Locations of certain features may therefore be somewhat wrong. In such cases the feature sought may best be located by its relation to a stream, swamp, lake, or other feature shown on the map.

PROFILES.

The locations of the profiles are shown on the map by dashed blue lines with black letters at the ends. Railroad profiles were furnished by the companies and show elevations of the ground rather than track in most cases; others are from road surveys by the State Highway Commission; most of them are hand level lines made by this Survey. Wherever possible the elevations above sea level are given. These elevations vary from 1050 to 1770 feet. A local datum plane was necessarily assumed in some cases. These cases are identifiable by the fact that the base line is always numbered 0.

LAND CLASSIFICATION.

This is shown on the map by the blue letters. It is explained in the following township description and at length in chapter V.

MAGNETIC DATA.

Dial compass readings are shown in blue figures. Eastward declinations are shown with a dot to the east and westward with a dot to west of the number. Dip needle readings are shown in black. All are positive except those preceded by the negative sign. All readings show deviation of needles from the normal reading of the instrument used. Normal readings are omitted from the map except at each quarter section corner. All abnormal readings are shown.

Traverses were made on lines indicated—usually the N-S section and quarter lines. Dip needle readings were taken each 50 paces, dial compass readings each 100 paces when sun permitted.

Magnetic lines are indicated by heavy black lines, solid where definite and dashed where doubtful.

CAUTION: Almost any kind of rock may be the cause of magnetic attraction. Do not fail to read the following description of this township, and also chapter IV., in which the magnetic attractions are discussed.

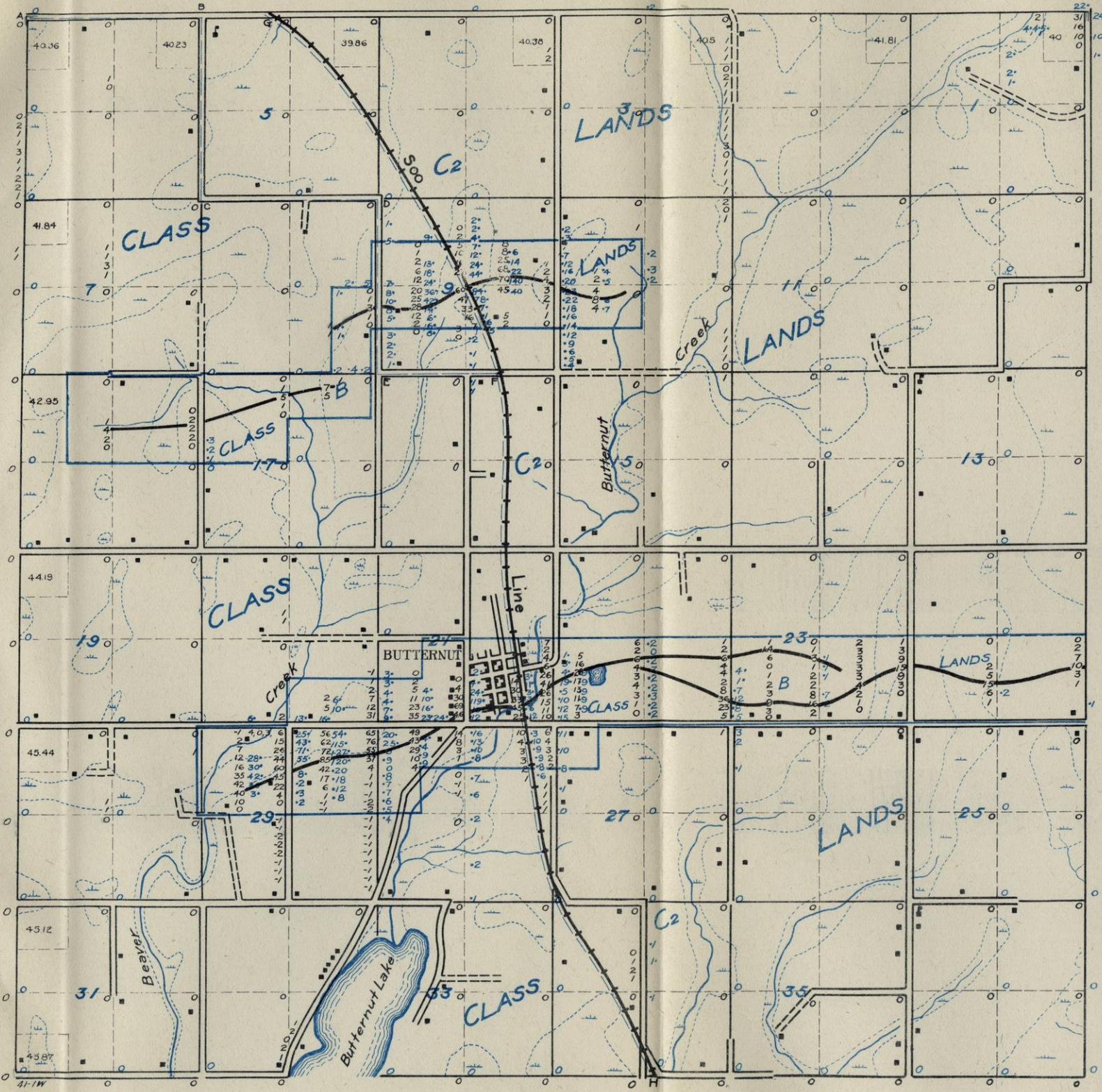

PROFILES

VERTICAL SCALE: 1 space = 20'  
HORIZONTAL SCALE: same as map.

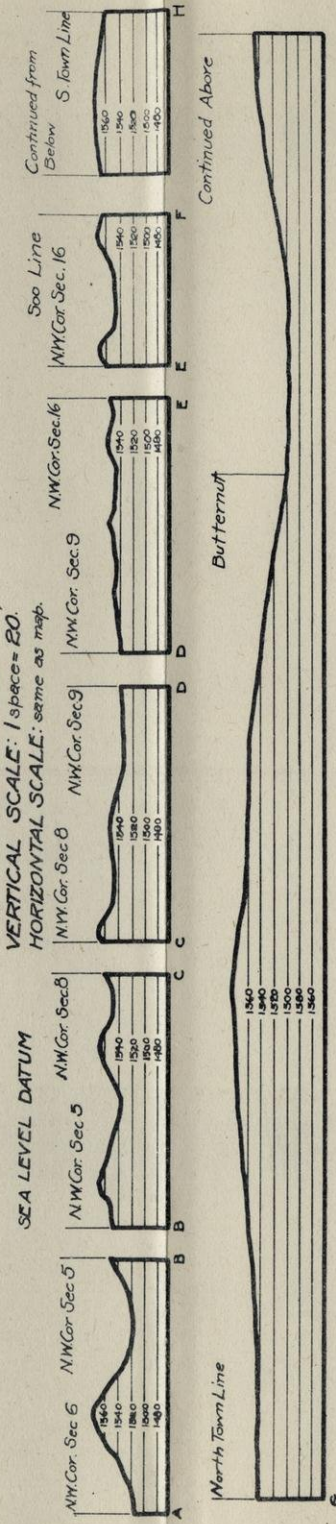

*Exploration.*—While iron formation undoubtedly exists in this township it is not considered to offer good prospects for iron ore since the exploration work done to the east has proven it to be a highly altered formation which is not likely to show concentration of iron ore. A number of years ago exploration was started near the village of Butternut, but the few shallow pits which were put down did not reach the ledge. It is believed that a small amount of exploration in the vicinity of the magnetic lines is warranted. Unless the iron formation shows good characteristics the work should not be carried on extensively. The greatest attraction may be due to the presence of sedimentary schists accompanying the iron formation, in which case a reasonable amount of drilling away from the maximum attraction is advisable. Much of the work done in exploration for iron ore is wasted because of failure to make intelligent use of the geologic and magnetic data to be obtained by a careful preliminary survey, and because the geologic information given by the drill is not properly used as a guide for further work. The value of careful scientific methods of exploration therefore cannot be too strongly emphasized. If exploration is contemplated in this township the discussion of this subject in Chapter VI should be carefully studied.



## TOWNSHIP 41 N.; RANGE 2 W.

*Surface Features.*—This township presents variety of topographic conditions but no unusual features. The surface as a whole is strongly undulating with relief varying up to 70 or 80 feet. The drainage is chiefly through Pine Creek which flows south through the center of the township in a rather wide valley that suggests a pre-glacial origin. It is possible that the East Fork of the Chippewa at one time occupied this valley. Areas of rough knob and kettle topography are found in sections 6, 7 and 18 and in the west sides of sections 3 and 10. Most of the east half of the township is characterized by a series of pronounced hills trending slightly east of north and usually having gentle slopes. A flat plain occupies most of sections 2, 10 and 11 and parts of sections 1, 12, 14 and 15.

The settled eastern side of this township is well supplied with good roads but the west is practically without any. Large quantities of hemlock and hardwood remain uncut in the south half and smaller scattered areas remain in the north half of the township.

*Glacial Drift.*—The rough areas in sections 6, 7 and 18 and in sections 3 and 10 are typical terminal moraines characterized by knobs and kettles and steep slopes. The drift is composed of sand, gravel and bowlders. The flat plain in the northeastern portion is an outwash deposit composed of sand and some gravel. The remainder of the township is covered by ground moraine deposits of silt, sand, gravel and bowlders. The bowlders are very numerous in places. The relief of the area of pronounced ridges is suggestive of terminal moraine but in the character of the drift and the undulating nature of the surface it is more like the ground moraine areas.

The depth of the drift is not known. There are a number of wells in the township, some of which reach a depth of nearly 90 feet without encountering ledge and it is assumed that the depth of drift will exceed 100 feet in nearly all places.

*General Geology.*—No rock exposures were found in this township and nothing definite is known as to the character of the underlying rock. Very strong magnetic lines in the township to the east strike nearly east and west, but stop abruptly before reaching the township line, a fact which suggests the existence of an intrusive mass of granite. The attraction in T. 41-1 W. is thought quite certainly to indicate the presence of an iron formation and there is a possibility that this same formation in a non-magnetic form will be found in T. 41-2 W. It frequently happens that magnetic iron formation

# TOWN 41 N., R. 2W.

Survey Made in July, 1913

Under the Direction of  
**W. O. HOTCHKISS**, State Geologist  
AND  
**E. F. BEAN** and **O. W. WHEELWRIGHT**,  
in charge of Field Parties

BY  
**H. H. BRADT**, Chief of Party  
**L. M. SCHINDLER**, Asst. Geologist  
**J. O. BRYANT**, Asst. Geologist

### SYMBOLS AND ABBREVIATIONS.

The symbols and abbreviations used on this map are explained in Chapter II.

### TOWN AND RANGE LINES.

In constructing this map the south line of the township was laid off as a true east west line. The other boundary lines were then laid off with the lengths shown on the Land Survey plat. Some of the maps are therefore incorrect in shape but this is necessary because definite facts are lacking. The acreage of part of the lots in the north and west tier of sections is shown to give a check on the distances in these sections.

### LOCATIONS.

All locations are based on pacing traverses from government land corners. In many cases these were not found and it was necessary to continue the traverse several miles without a check. Locations of certain features may therefore be somewhat wrong. In such cases the feature sought may best be located by its relation to a stream, swamp, lake, or other feature shown on the map.

### PROFILES.

The locations of the profiles are shown on the map by dashed blue lines with black letters at the ends. Railroad profiles were furnished by the companies and show elevations of the ground rather than track in most cases; others are from road surveys by the State Highway Commission; most of them are hand level lines made by this Survey. Wherever possible the elevations above sea level are given. These elevations vary from 1050 to 1770 feet. A local datum plane was necessarily assumed in some cases. These cases are identifiable by the fact that the base line is always numbered 0.

### LAND CLASSIFICATION.

This is shown on the map by the blue letters. It is explained in the following township description and at length in chapter V.

### MAGNETIC DATA.

Dial compass readings are shown in blue figures. Eastward declinations are shown with a dot to the east and westward with a dot to west of the number. Dip needle readings are shown in black. All are positive except those preceded by the negative sign. All readings show deviation of needles from the normal reading of the instrument used. Normal readings are omitted from the map except at each quarter section corner. All abnormal readings are shown.

Traverses were made on lines indicated—usually the N-S section and quarter lines. Dip needle readings were taken each 50 paces, dial compass readings each 100 paces when sun permitted.

Magnetic lines are indicated by heavy black lines, solid where definite and dashed where doubtful.

**CAUTION:** Almost any kind of rock may be the cause of magnetic attraction. Do not fail to read the following description of this township, and also chapter IV., in which the magnetic attractions are discussed.

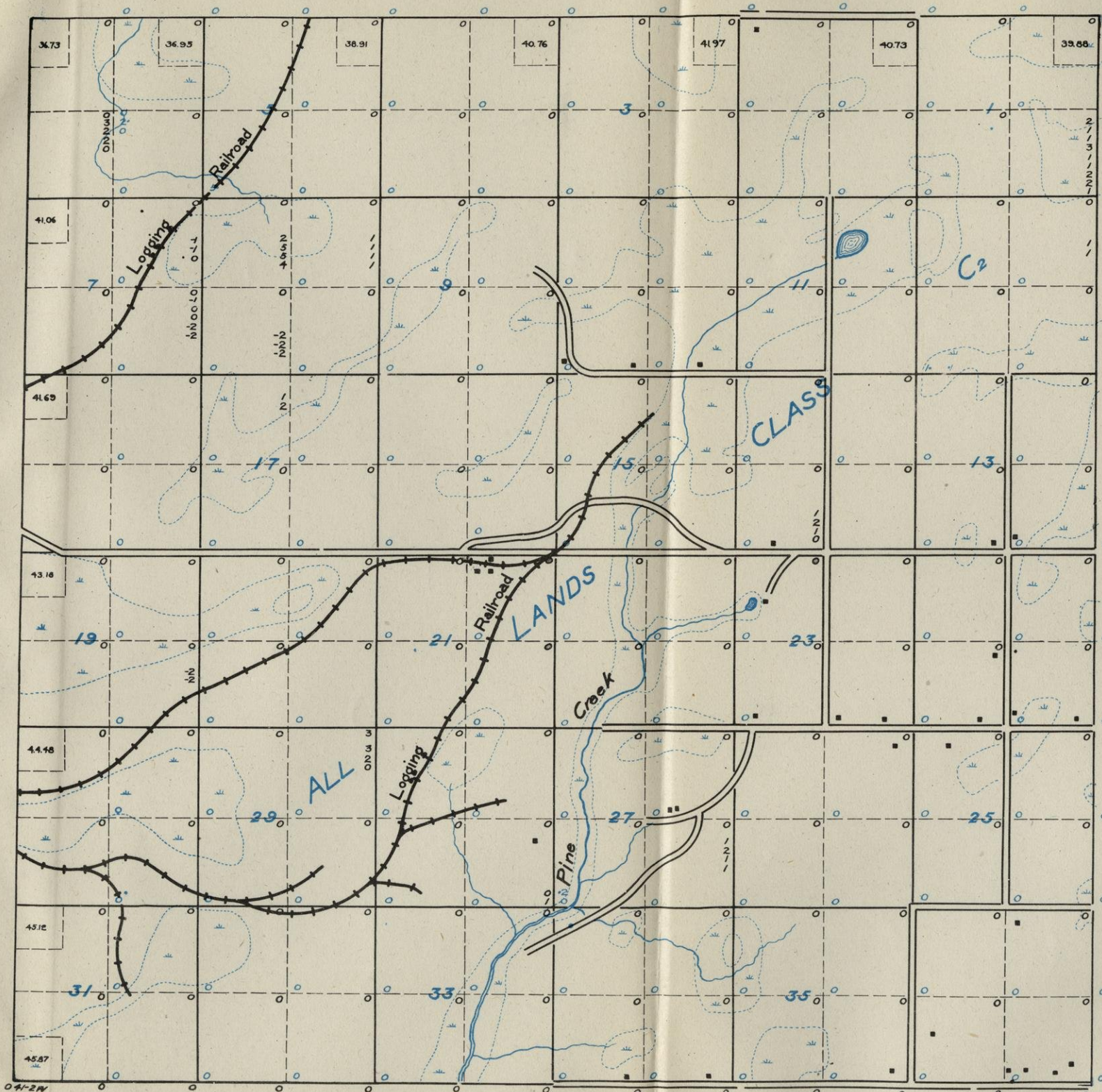

becomes non-magnetic along the strike and in the non-magnetic form is much more likely to produce ore. The abrupt break in the line does not favor this view, however, since in such cases the attraction usually dies out gradually. It is believed that granite underlies this township but the other possibility must be recognized.

*Magnetic Observations.*—A discussion of magnetic observations and their significance is given in Chapter IV. Only very irregular attraction was found which is not considered to indicate the presence of iron formation but rather confirms the view that granites are the underlying rock.

*Land Classification.*—The principles of land classification employed in this work are discussed in Chapter V. Because of lack of definite information, all lands in this township are placed in class C2. It is recognized that there is some possibility of the existence of iron formation, but there is nothing to indicate it and therefore no higher classification of the lands is possible. Neither is the presence of granite established so that it is not advisable to classify any as D lands.

*Exploration.*—Exploration in this township cannot be recommended unless work in the township to the east gives good reason for believing that the iron formation does not stop at the end of the magnetic line.

## TOWNSHIP 41 N., RANGE 6 W.

*Surface Features.*—Along the Chippewa River and for some distance back from it and in the northern third of the township the surface is rather rough. Slopes are steep and relief of 80 to 100 feet is common. The remainder has a more gently undulating surface, but it is also somewhat rough in places, as along the road just west of the center of the township. There are several swamps of considerable size and many small lakes filling the depressions in the drift. The Chippewa has eroded a deep narrow channel. The dam at the east side of section 14 has backed the water up to form a lake. The profiles on the map give a fair idea of the topography of the country. The roughness along the Chippewa River is well shown by profile B-C.

The roads are ungraded and in poor condition. The one near the north township line is the most used and is passable for automobiles during the summer season. Considerable quantities of hardwood and hemlock are left in nearly all parts of the township. Settlers are few because of great distance from the railroad and the poor condition of the roads.

*Glacial Drift.*—There is a strong terminal moraine trending across the northern part of the township in a belt from  $\frac{1}{2}$  to 2 miles wide. It is characterized by great ruggedness and the more sandy nature of the drift. A small area of terminal moraine also occurs west of the center of the township. With the exception of a few small areas of outwash along the river all the remainder of the township is ground moraine. The drift consists of sand, silt, gravel and boulders. The latter are not numerous as a rule.

There is no information as to the depth of the drift since there are no exposures of rock and only a few very shallow wells. It is assumed, however, that the thickness will exceed 100 feet in nearly all parts of the township except possibly along the river.

*General Geology.*—This township is located in an area where rock exposures are of very rare occurrence and information bearing on the character of the underlying rocks is very difficult to obtain. At the dam in section 14 a large number of boulders of igneous rocks suggest that the ledge is not deeply buried at this point, but information obtained from these cannot be taken as conclusive as to the character of the rock for very much of the township. The results of the magnetic work suggest that all except the southwestern part is underlain by Huronian rocks.

TOWN 41 N., R. 6W.

Survey Made in July, 1914

Under the Direction of  
W. O. HOTCHKISS, State Geologist

AND  
E. F. BEAN and O. W. WHEELWRIGHT,  
in charge of Field Parties

BY  
J. P. GOLDSBERRY, Chief of Party

C. W. HONESS, Asst. Geologist

T. M. LANGLEY, Asst. Geologist

SYMBOLS AND ABBREVIATIONS.

The symbols and abbreviations used on this map are explained in Chapter II.

TOWN AND RANGE LINES.

In constructing this map the south line of the township was laid off as a true east west line. The other boundary lines were then laid off with the lengths shown on the Land Survey plat. Some of the maps are therefore incorrect in shape but this is necessary because definite facts are lacking. The acreage of part of the lots in the north and west tier of sections is shown to give a check on the distances in these sections.

LOCATIONS.

All locations are based on pacing traverses from government land corners. In many cases these were not found and it was necessary to continue the traverse several miles without a check. Locations of certain features may therefore be somewhat wrong. In such cases the feature sought may best be located by its relation to a stream, swamp, lake, or other feature shown on the map.

PROFILES.

The locations of the profiles are shown on the map by dashed blue lines with black letters at the ends. Railroad profiles were furnished by the companies and show elevations of the ground rather than track in most cases; others are from road surveys by the State Highway Commission; most of them are hand level lines made by this Survey. Wherever possible the elevations above sea level are given. These elevations vary from 1050 to 1770 feet. A local datum plane was necessarily assumed in some cases. These cases are identifiable by the fact that the base line is always numbered 0.

LAND CLASSIFICATION.

This is shown on the map by the blue letters. It is explained in the following township description and at length in chapter V.

MAGNETIC DATA.

Dial compass readings are shown in blue figures. Eastward declinations are shown with a dot to the east and westward with a dot to west of the number. Dip needle readings are shown in black. All are positive except those preceded by the negative sign. All readings show deviation of needles from the normal reading of the instrument used. Normal readings are omitted from the map except at each quarter section corner. All abnormal readings are shown.

Traverses were made on lines indicated—usually the N-S section and quarter lines. Dip needle readings were taken each 50 paces, dial compass readings each 100 paces when sun permitted.

Magnetic lines are indicated by heavy black lines, solid where definite and dashed where doubtful.

CAUTION: Almost any kind of rock may be the cause of magnetic attraction. Do not fail to read the following description of this township and also chapter IV., in which the magnetic attractions are discussed.

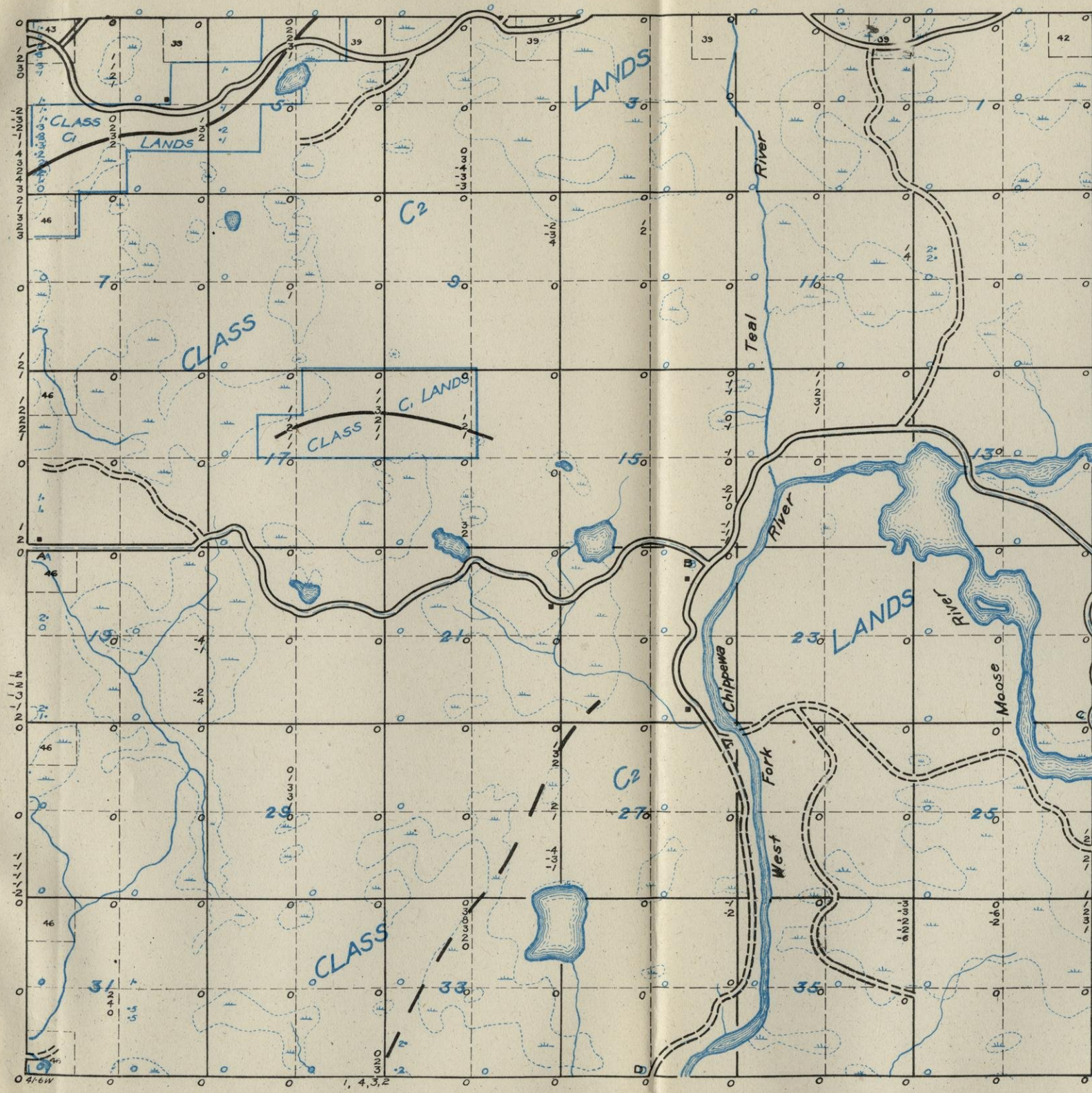

PROFILES

VERTICAL SCALE: 1 space = 20'  
HORIZONTAL SCALE: 5 bars = 500'

LOCAL DATUM

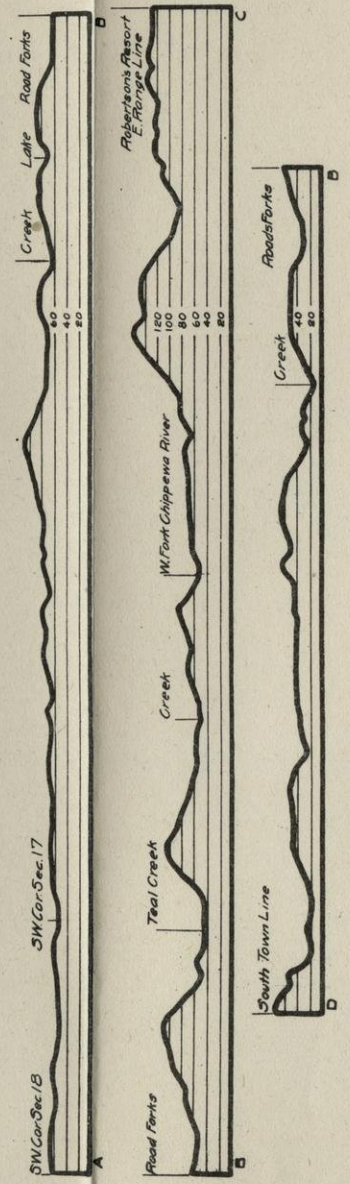

*Magnetic Observations.*—For a general discussion of magnetic observation and their significance, the reader is referred to Chapter IV. Mild positive and negative dip needle readings are obtained in scattered areas in many parts of the township. A fairly well defined line of positive attractions is found in sections 5 and 6 and continues in an indefinite way in the northeastern part of T. 41-7 W., where it connects with lines which are thought quite certainly to be due to iron formation. A short mild line is also shown in sections 16 and 17. There is a suggestion of a line striking about N. 30° E. in sections 28 and 33.

*Land Classification.*—The principles of land classification employed in this work are discussed in Chapter V. Those lands in sections 5 and 6 directly on the magnetic line are placed in class C1. The same classification is given lands on the short magnetic line in sections 16 and 17. All other lands in the township are placed in class C2, although the general location is such that they are considered rather more promising as mineral prospects than much of the land in this class.

*Exploration.*—The magnetic line in sections 5 and 6 is of such character and so located with reference to the lines in the township west that it offers some inducement to the explorer. The other lines are less attractive. Much of the work done in exploration for iron ore is wasted because of failure to make intelligent use of the geologic and magnetic data to be obtained by a careful preliminary survey, and because the geologic information given by the drill is not properly used as a guide for further work. The value of careful scientific methods of exploration therefore cannot be too strongly emphasized. If exploration is contemplated in this township the discussion of this subject in chapter VI should be carefully studied.

## TOWNSHIP 41 N., RANGE 7 W.

1:

*Surface Features.*—An area of rugged topography extends through the south central, central and northwestern parts of the township. The north fork of Chief River drains this area and Upper Twin, Lower Twin and Callahan lakes occupy basins formed by the blocking of its valley by glacial drift. In the southwestern part of the township is a sandy plain, quite level to the east but dissected by streams near Round Lake. Another sandy plain covers a large part of sections 3 and 4. Outside the areas above described, the topography is for the most part gently undulating. The important features shown by profile A-B are the flat area extending for a mile west of the  $\frac{1}{4}$  corner of sections 9 and 16, the valley of Spider Creek near the southwest corner of section 10 and the undulating topography to the east of Spider Creek valley.

The main traveled roads are quite good. The only hardwood of importance is in the central and west central parts of the township and in section 24. There is considerable cedar and tamarack in the swamps. The western part of the area is well settled and there are several very prosperous farms.

*Glacial Drift.*—The northwestern, central and south central parts of this township are included in a belt of terminal moraine. The southern part of this belt is extremely rough and is much higher than the northern part where it is characterized by low sand and gravel hills, with numerous lakes and swamps. In the southwest there is an area of pitted outwash. Near Round Lake this plain is dissected by streams flowing into the lake. In sections 3 and 4 is another outwash plain which is gently undulating. There are no lakes here but swamps occupy some of the depressions. East of the terminal moraine is ground moraine. The ground moraine area lying in the north central part of the township is comparatively level, and has swampy areas extending across it from north to south. The eastern part of the township is more roughly undulating. The glacial deposits are sand, gravel and bowlders in the terminal moraine; sand with some silt in the outwash; sand, silt, some gravel and numerous bowlders in the ground moraine.

There are no outcrops in the township and wells averaging 45 feet in depth do not reach ledge. Some careful magnetic work done by W. L. Dobie, according to the method outlined on page 81, indicates that the drift cover probably exceeds 200 feet in thickness over the strong magnetic line in section 17.

*General Geology.*—There are no exposures of rock in this township and none in those adjoining from which to obtain an idea of the character of the underlying rock. All geological inferences are drawn from the magnetic work and are discussed below.

*Magnetic Observations.*—Magnetic observations and their significance are discussed in Chapter IV. This should be studied before attempting to interpret the results of the work in this township. There is magnetic attraction of varying intensity over nearly all of this township. Much of the attraction is negative in character. In most cases it is mild and lines connecting the maximum readings are of doubtful value, but in others the lines are very well defined. In the north central part there is a very unusual condition, in that there is a well defined line showing negative readings as high as 70°. Six successive traverses  $\frac{1}{2}$  mile apart over this line show maximum readings greater than 30°. The line is very distinct for four miles and probably continues under Round Lake on the west. It will be noted that in crossing this line of attraction (which strikes northeast) the dial readings are also the reverse of the ordinary in that the north end of the needle points east while approaching it from the south, and west after crossing the line of maximum attraction. South of this negative belt and parallel to it is a line of positive attraction somewhat milder in character but still very definite. The two lines become rather indistinct in sections 11 and 14 and it appears that they may possibly come together as at the end of the fold. The evidence obtained from these lines suggest strongly the presence of magnetic iron formation, folded into a syncline and acting as a horseshoe magnet, with the north limb repelling the north end of the needle and the south limb attracting it. The less definite attractions found elsewhere in the township do not permit of ready explanation. Undoubtedly the drift contains many boulders and much magnetic sand from the formations which cause this strong attraction and there is no doubt but that some of these more irregular mild attractions are due to this, but since the attractions occur on all sides of the formation some of it must have a different cause. Igneous rocks or less magnetic formations similar to those causing the strong attraction may be the explanation.

*Land Classification.*—The general principles of land classification employed in this work are discussed in Chapter V. All lands underlain by the definite magnetic attractions above discussed are classed as B lands because the presence of an iron formation in this vicinity seems practically certain. All other lands in this township are



placed in class C2, because of lack of definite information, but future exploratory work may prove that some of them deserve a higher classification.

*Exploration.*—It is believed that exploration on the main line of attractions in this township offers good promise of profitable returns. While the formation is magnetic, the strength is so remarkable that it suggests the presence of magnetic ore such as that found in the Republic trough in Michigan. Such work should be preceded by more detailed magnetic surveys. Indications point to thick glacial drift in this vicinity and drilling will probably prove expensive. Much of the work done in exploration for iron ore is wasted because of failure to make intelligent use of the geologic and magnetic data to be obtained by a careful preliminary survey, and because the geologic information given by the drill is not properly used as a guide for further work. The value of careful scientific methods of exploration therefore cannot be too strongly emphasized. If exploration is contemplated in this township the discussion of this subject in Chapter VI should be carefully studied.

TOWN 41 N., R. 7W.

Survey Made in July, 1914

Under the Direction of  
W. O. HOTCHKISS, State Geologist  
AND

E. F. BEAN and O. W. WHEELWRIGHT,  
in charge of Field Parties

BY

L. J. YOUNGS, Chief of Party  
H. N. EIDEMILLER, Asst. Geologist  
F. R. PRETYMAN, Asst. Geologist

SYMBOLS AND ABBREVIATIONS.

The symbols and abbreviations used on this map are explained in Chapter II.

TOWN AND RANGE LINES.

In constructing this map the south line of the township was laid off as a true east west line. The other boundary lines were then laid off with the lengths shown on the Land Survey plat. Some of the maps are therefore incorrect in shape but this is necessary because definite facts are lacking. The acreage of part of the lots in the north and west tier of sections is shown to give a check on the distances in these sections.

LOCATIONS.

All locations are based on pacing traverses from government land corners. In many cases these were not found and it was necessary to continue the traverse several miles without a check. Locations of certain features may therefore be somewhat wrong. In such cases the feature sought may best be located by its relation to a stream, swamp, lake, or other feature shown on the map.

PROFILES.

The locations of the profiles are shown on the map by dashed blue lines with black letters at the ends. Railroad profiles were furnished by the companies and show elevations of the ground rather than track in most cases; others are from road surveys by the State Highway Commission; most of them are hand level lines made by this Survey. Wherever possible the elevations above sea level are given. These elevations vary from 1050 to 1770 feet. A local datum plane was necessarily assumed in some cases. These cases are identifiable by the fact that the base line is always numbered 0.

LAND CLASSIFICATION.

This is shown on the map by the blue letters. It is explained in the following township description and at length in chapter V.

MAGNETIC DATA.

Dial compass readings are shown in blue figures. Eastward declinations are shown with a dot to the east and westward with a dot to west of the number. Dip needle readings are shown in black. All are positive except those preceded by the negative sign. All readings show deviation of needles from the normal reading of the instrument used. Normal readings are omitted from the map except at each quarter section corner. All abnormal readings are shown.

Traverses were made on lines indicated—usually the N-S section and quarter lines. Dip needle readings were taken each 50 paces, dial compass readings each 100 paces when sun permitted.

Magnetic lines are indicated by heavy black lines, solid where definite and dashed where doubtful.

CAUTION: Almost any kind of rock may be the cause of magnetic attraction. Do not fail to read the following description of this township, and also chapter IV., in which the magnetic attractions are discussed.

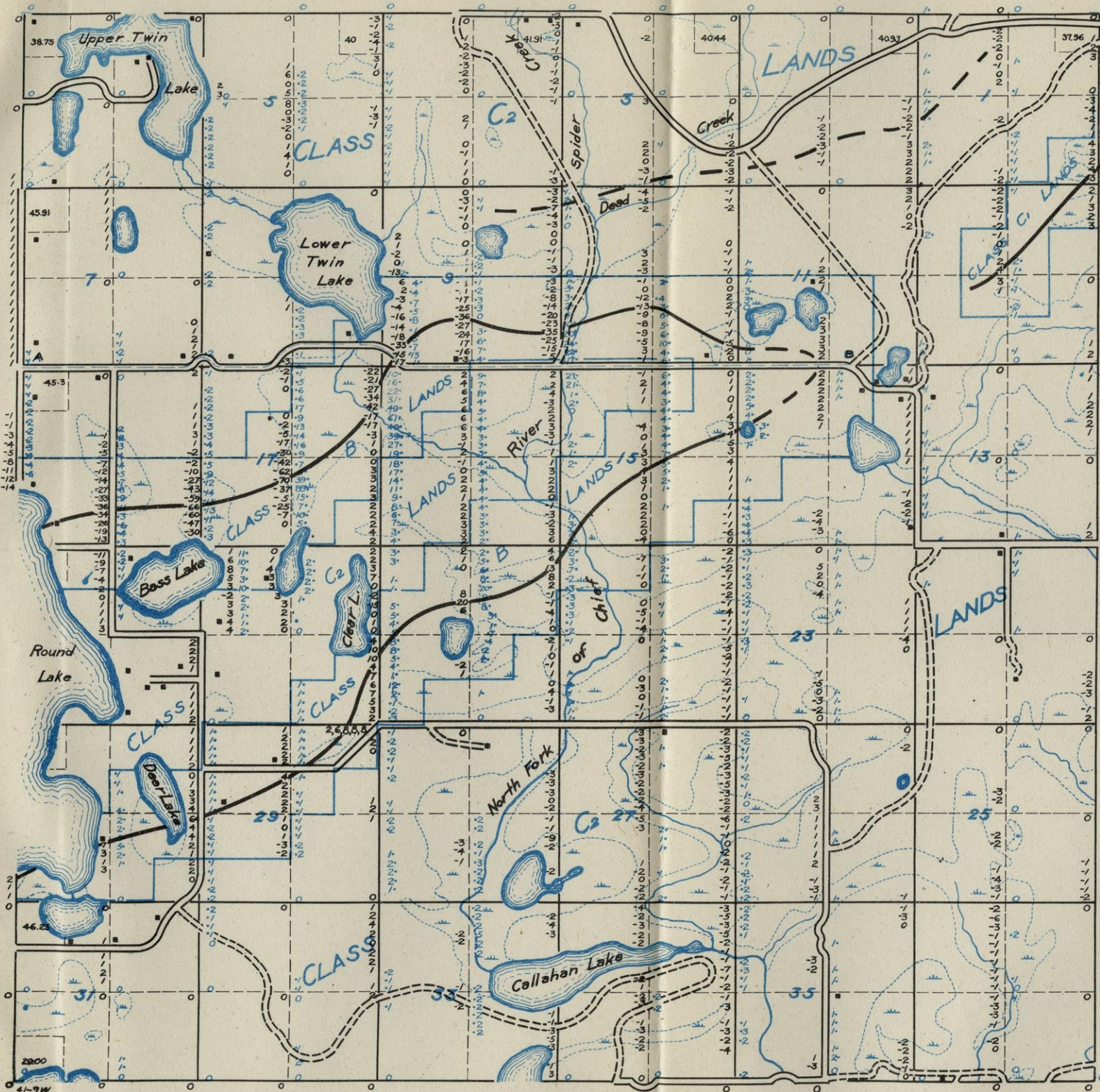

PROFILE  
VERTICAL SCALE: 1 space = 20'  
HORIZONTAL SCALE: same as map

LOCAL DATUM

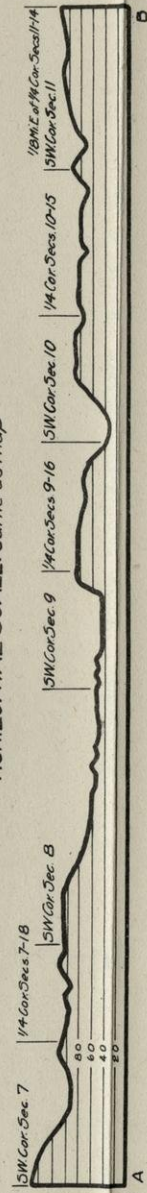

41-7W

## TOWNSHIP 41 N., RANGE 8 W.

*Surface Features.*—The northwest part of this township is a plain, southeast of which, in the western and northern parts, is rugged topography. An area of gently undulating topography lies west and north of Round Lake. There is also a large area of level to gently undulating topography in the south central part of the township. The relief in the northwest part, as shown on profile A-B, is very slight. Profile C-D shows that the eastern part of the township in section 12 is 140 feet higher than the southwestern part of section 19.

Most of the roads of the township are good. Practically no timber of value remains. The more level parts of the township are well settled.

*Glacial Drift.*—Two areas of outwash are found, one in the northwest and the other in the south central part of the township. Terminal moraine, rising in places to an elevation of 150 feet above the outwash to the northwest, covers the north part from the west line of section 1 to the middle of 5, extends south to the center of the township, then in a narrow belt through 18 and 19 to connect with a large area covering 30 and 31 and the west half of 29 and 32. Within this moraine the topography is very rugged, the relief being as much as 60 to 70 feet. West and north of Round Lake is gently undulating ground moraine.

The glacial deposits are much sand with a small percentage of silt in the outwash; sand, gravel and boulders with some silt in the terminal moraine; silt, some sand and boulders in the ground moraine.

The thickness of drift is not definitely known, as wells are shallow and none are known to reach ledge. From the relief within the terminal moraine and its elevation above the outwash plain, and from the thickness in the township east it is probable that 200 to 300 feet or more will be found in much of the township.

*General Geology.*—There are no exposures of rock and the only evidence bearing upon the geology is obtained from its general location and from the results of magnetic work. It is believed that the Keweenawan traps underlie sections 4, 5, 6, the west half of section 3, parts of the north half of sections 7, 8, 9, and the west half of section 18. Huronian rocks probably underlie the remainder of the township. There is good reason for believing that sandstone will be found over the older rocks in the western part.

*Magnetic Observations.*—For a general discussion of magnetic observations and their significance the reader is referred to chapter IV. The northwestern part of the township shows considerable attraction of irregular character which is believed to be caused by the Keweenaw traps. The dip needle readings are low and the limits of the area are indistinctly marked. In sections 25, 35, and 36 is a line of attraction which is continuous with the strong line in T. 41-7 W. On the north shore of Round Lake strong negative attractions were obtained on the township line so that it is believed that both limbs of the supposed syncline in T. 41-7 W. extend into this township. Attractions in these last two named localities are believed to be caused by iron formation.

*Land Classification.*—The principles of land classification employed in this work are discussed in Chapter V. Lands located on the well defined magnetic lines in the eastern part of the township are placed in class B. Those in the northwestern part which are supposed to be underlain by the Keweenaw traps are placed in class D, although it cannot be asserted positively that the trap rocks exist here. All other lands in the township are placed in class C2.

*Exploration.*—As stated above, the attractions in sections 13, 25, 35 and 36 are thought to be due to iron formation. The most favorable place for exploration would be in sections 35 and 36. It is also probable that the lands west of Round Lake on the strike of the strong negative line deserve some attention. The attraction dies out but it is not improbable that the iron formation continues into this township. Much of the work done in exploration for iron ore is wasted because of failure to make intelligent use of the geologic and magnetic data to be obtained by a careful preliminary survey, and because the geologic information given by the drill is not properly used as a guide for further work. The value of careful scientific methods of exploration therefore cannot be too strongly emphasized. If exploration is contemplated in this township the discussion of this subject in Chapter VI should be carefully studied.

**TOWN 41 N., R. 8W.**

Survey Made in August, 1914

Under the Direction of

W. O. HOTCHKISS, State Geologist

AND

E. F. BEAN and O. W. WHEELWRIGHT,  
in charge of Field Parties

BY

T. M. BRODERICK, Chief of Party

H. N. EIDEMILLER, Asst. Geologist

F. R. PRETYMAN, Asst. Geologist

**SYMBOLS AND ABBREVIATIONS.**

The symbols and abbreviations used on this map are explained in Chapter II.

**TOWN AND RANGE LINES.**

In constructing this map the south line of the township was laid off as a true east west line. The other boundary lines were then laid off with the lengths shown on the Land Survey plat. Some of the maps are therefore incorrect in shape but this is necessary because definite facts are lacking. The acreage of part of the lots in the north and west tier of sections is shown to give a check on the distances in these sections.

**LOCATIONS.**

All locations are based on pacing traverses from government land corners. In many cases these were not found and it was necessary to continue the traverse several miles without a check. Locations of certain features may therefore be somewhat wrong. In such cases the feature sought may best be located by its relation to a stream, swamp, lake, or other feature shown on the map.

**PROFILES.**

The locations of the profiles are shown on the map by dashed blue lines with black letters at the ends. Railroad profiles were furnished by the companies and show elevations of the ground rather than track in most cases; others are from road surveys by the State Highway Commission: most of them are hand level lines made by this Survey. Wherever possible the elevations above sea level are given. These elevations vary from 1050 to 1770 feet. A local datum plane was necessarily assumed in some cases. These cases are identifiable by the fact that the base line is always numbered 0.

**LAND CLASSIFICATION.**

This is shown on the map by the blue letters. It is explained in the following township description and at length in chapter V.

**MAGNETIC DATA.**

Dial compass readings are shown in blue figures. Eastward declinations are shown with a dot to the east and westward with a dot to west of the number. Dip needle readings are shown in black. All are positive except those preceded by the negative sign. All readings show deviation of needles from the normal reading of the instrument used. Normal readings are omitted from the map except at each quarter section corner. All abnormal readings are shown.

Traverses were made on lines indicated—usually the N-S section and quarter lines. Dip needle readings were taken each 50 paces, dial compass readings each 100 paces when sun permitted.

Magnetic lines are indicated by heavy black lines, solid where definite and dashed where doubtful.

**CAUTION:** Almost any kind of rock may be the cause of magnetic attraction. Do not fail to read the following description of this township, and also chapter IV., in which the magnetic attractions are discussed.

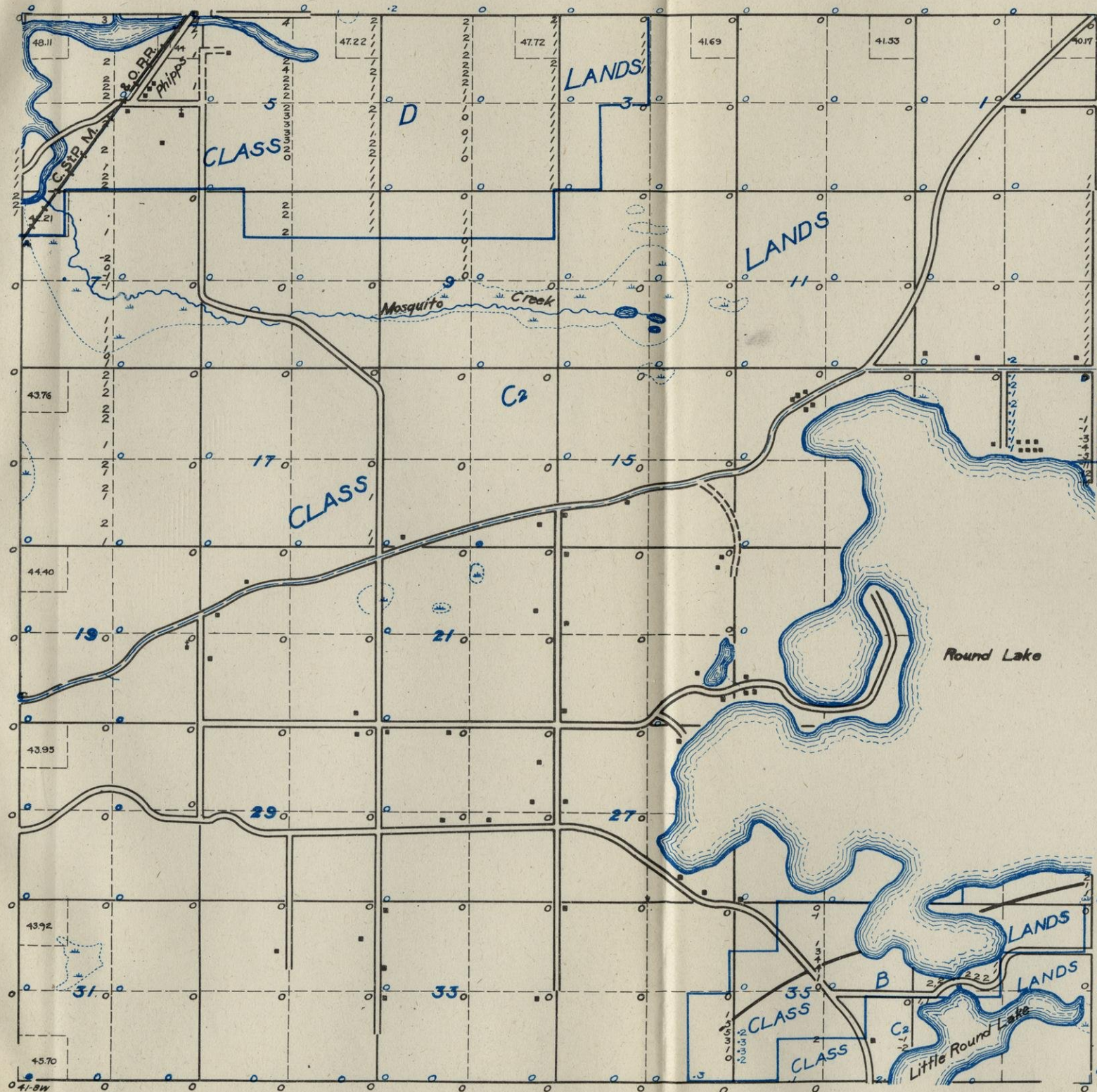

**PROFILES**  
VERTICAL SCALE 1 space = 20'.  
HORIZONTAL SCALE same as map.

SEA LEVEL DATUM  
vs. Range Line

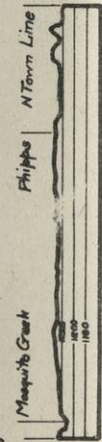

LOCAL DATUM

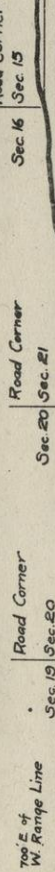

East Range Line



## TOWNSHIP 41 N., RANGE 9 W.

*Surface Features.*—Northwest of a line connecting the northeast and southwest corners of the township the topography is in general roughly undulating. In the extreme southeast is another area of roughly undulating topography. Between these areas and considerably below them is a sandy plain. Profile A-B shows the general level surface of the plain, which has a southwestward slope of 8 feet per mile. The hills in section 2 (profile G-H) rise nearly 120 feet above the plain to the west and in section 10 rise 80 feet above Smith Lake.

The roads in the sandy plain are not well graded but the drainage is so good that they are usually in good condition. In the rougher country the roads are rocky in places and have heavy grades. With the exception of the cedar and tamarack in the swamps, all the timber has been cut. The plain is well settled, but the topography of the highland makes cultivation more difficult and these areas are not so well settled.

*Glacial Drift.*—Gently undulating ground moraine occurs in section 3 and west of Smith Lake in sections 4 and 5. Outside the areas of ground moraine, the northwest half of the township is terminal moraine with knob and kettle topography. In the depressions are swamps and small lakes. Extending southwest across the southeast corner of the township is roughly undulating terminal moraine. Between the terminal moraines is an outwash plain averaging 3 miles in width, well drained except along its southeast edge where there are swamps.

Glacial deposits are chiefly sand and gravel with some silt and numerous boulders in the terminal moraine; sand, gravel, silt and boulders in the ground moraine; much sand and a small percentage of silt in the outwash.

A new well at Hayward reports ledge at a depth of 70 feet. No ledge is reported in other wells, although there are some in the northwest part of the township which have penetrated drift to depths of 120 to 152 feet. It seems probable that outside the outwash plain the drift is considerably over 100 feet in thickness.

*General Geology.*—There are no exposures of rock in this township. A well now being drilled in the city of Hayward struck sandstone at a depth of 70 feet and at the time of going to press had penetrated to a depth of 230 feet in this rock. From samples furnished by Mr. F. A. Dailey it appears that this is Cambrian sandstone.

The inferences as to the character of the older rocks are drawn from the results of magnetic work in this and in the adjoining townships. From these it appears that the trap rock may extend into the eastern half of section 1 but the absence of magnetics to the west indicates either that it takes a sharp turn toward the north, is faulted off in this vicinity, or is so deeply buried by the sandstone that it does not affect the magnetic needle. If the trap is present, as appears to be the case, Huronian rocks may occupy only the southeastern part of the township beneath the sandstone cover.

*Magnetic Observations.*—For a general discussion of magnetic observations and their significance the reader is referred to Chapter IV. This township, except on the east line of section I, is almost entirely free from magnetic attraction. A few small areas of very mild attraction are found in sections 5, 7 and 14. The presence of attraction in the northeast part and in the township to the east is thought to indicate the presence of Keweenawan traps. The absence of attraction over the rest of the township probably results from the deeper burial of these rocks.

*Land Classification.*—The principles of land classification employed in this work are explained in Chapter V. The east half of section I is placed in class D because there is here good evidence of the presence of trap rock. All other lands are placed in class C2 because the evidence is not of sufficiently definite character to warrant division into other classes.

*Exploration.*—Exploration for iron ore in this township is not recommended.

TOWN 41 N., R. 9 W.

Survey Made in June, 1914

Under the Direction of  
W. O. HOTCHKISS, State Geologist

AND  
E. F. BEAN and O. W. WHEELWRIGHT,  
in charge of Field Parties

BY  
T. M. BRODERICK, Chief of Party

H. D. WAKEFIELD, Asst. Geologist

R. S. TARR, Asst. Geologist

**SYMBOLS AND ABBREVIATIONS.**

The symbols and abbreviations used on this map are explained in Chapter II.

**TOWN AND RANGE LINES.**

In constructing this map the south line of the township was laid off as a true east west line. The other boundary lines were then laid off with the lengths shown on the Land Survey plat. Some of the maps are therefore incorrect in shape but this is necessary because definite facts are lacking. The acreage of part of the lots in the north and west tier of sections is shown to give a check on the distances in these sections.

**LOCATIONS.**

All locations are based on pacing traverses from government land corners. In many cases these were not found and it was necessary to continue the traverse several miles without a check. Locations of certain features may therefore be somewhat wrong. In such cases the feature sought may best be located by its relation to a stream, swamp, lake, or other feature shown on the map.

**PROFILES.**

The locations of the profiles are shown on the map by dashed blue lines with black letters at the ends. Railroad profiles were furnished by the companies and show elevations of the ground rather than track in most cases; others are from road surveys by the State Highway Commission; most of them are hand level lines made by this Survey. Wherever possible the elevations above sea level are given. These elevations vary from 1050 to 1770 feet. A local datum plane was necessarily assumed in some cases. These cases are identifiable by the fact that the base line is always numbered 0.

**LAND CLASSIFICATION.**

This is shown on the map by the blue letters. It is explained in the following township description and at length in chapter V.

**MAGNETIC DATA.**

Dial compass readings are shown in blue figures. Eastward declinations are shown with a dot to the east and westward with a dot to west of the number. Dip needle readings are shown in black. All are positive except those preceded by the negative sign. All readings show deviation of needles from the normal reading of the instrument used. Normal readings are omitted from the map except at each quarter section corner. All abnormal readings are shown.

Traverses were made on lines indicated—usually the N-S section and quarter lines. Dip needle readings were taken each 50 paces, dial compass readings each 100 paces when sun permitted.

Magnetic lines are indicated by heavy black lines, solid where definite and dashed where doubtful.

**CAUTION:** Almost any kind of rock may be the cause of magnetic attraction. Do not fail to read the following description of this township, and also chapter IV., in which the magnetic attractions are discussed.

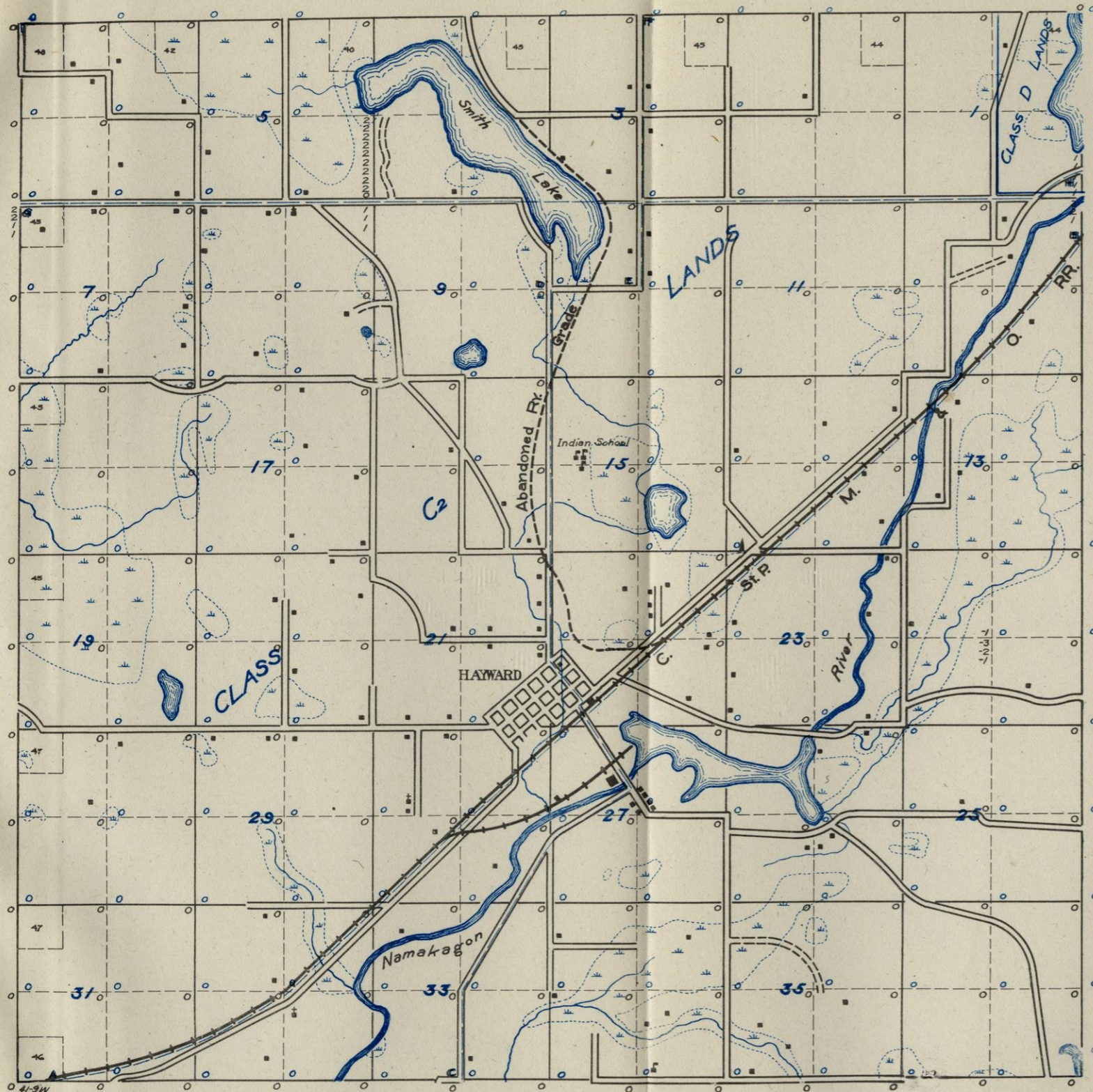

**PROFILES**  
VERTICAL SCALE: 1 space = 20'.  
HORIZONTAL SCALE: same as map.

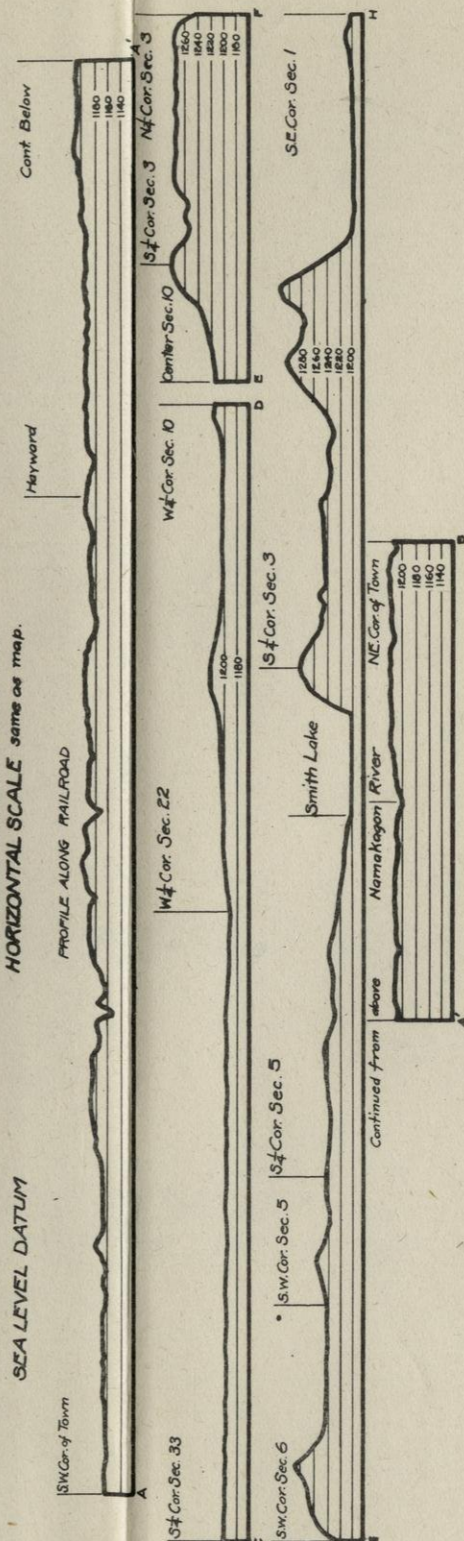



## TOWNSHIP 42 N., RANGE 2 W.

*Surface Features.*—Sand and gravel ridges trending S. 10° W. to S. 35° W. separated by gently undulating or flat areas constitute the principal topographic feature of this township. The Chippewa River enters the township in section 1, flows south and west to near the center of section 34, where it turns abruptly north for nearly 4 miles; then turns south and west, leaving the township near the southwest corner of section 31. A sandy plain borders the river throughout the area.

All the main travelled roads are very good. The Ashland county road is a splendid macadamized road. There is still some fairly good hardwood and hemlock in the northwest, central and southeast parts of the township. Except in the west part, this township is well settled and most of the farms are prosperous.

*Glacial Drift.*—For the greater part of its length in this township, the Chippewa River is bordered by an outwash plain. Belts of terminal moraine trending S. 10° W. to S. 35° W. constitute the most important topographic features of the township. In the southwestern part the terminal moraine is characterized by knobs and kettles. West of Glidden the ridges, which have a local relief of from 50 to 80 feet, are long and broad. The ridge extending through sections 14, 23 and 22 is narrower and rises 25 to 80 feet above the outwash plain to the west. Between the belts of terminal moraine are lower, level to gently undulating areas of ground moraine or outwash. In the northwestern part is a flat swampy area that was probably lake bottom at one time.

The glacial deposits are sand, with considerable silt, in the outwash; sand, gravel, boulders and some silt in the terminal moraine; sand, silt and boulders in the ground moraine.

There are no rock outcrops in the township and no wells are known to reach ledge. Since several wells penetrate drift to a depth of 85 feet, it seems probable that the depth of the drift averages 100 feet or more in thickness.

*General Geology.*—There are no exposures of rock and no information bearing directly on the character of the underlying formations. Because of the lack of magnetic attraction and because of conditions to the north and southeast it is thought likely that the township is underlain largely by granite. However, the evidence is inconclusive and the absence of Huronian sediments cannot be positively asserted. It is probable that both igneous and sedimentary

rocks of pre-Cambrian age underlie the township, and there is a slight possibility that iron formation may be present.

*Magnetic Observations.*—A general discussion of magnetic observations and their significance is given in Chapter IV. Some mild irregular attraction was found very locally but there are no well-defined lines of attraction of such a nature as to indicate the presence of sedimentary formations. Since this township is located in an area of great metamorphism where the iron formations are strongly magnetic the absence of such attraction is taken as a fairly conclusive evidence that no iron formation is present.

*Land Classification.*—The principles of land classification employed in this work are discussed in Chapter V. Even though believed to be underlain by granite, all lands in this township are placed in class C2 for lack of conclusive evidence.

*Exploration.*—Exploration for iron ore in this township is not recommended.

**TOWN 42 N., R. 2W.**

Survey Made in August, 1913

Under the Direction of  
**W. O. HOTCHKISS, State Geologist**  
AND  
**E. F. BEAN and O. W. WHEELWRIGHT,**  
in charge of Field Parties

BY  
H. H. BRADT, Chief of Party  
L. M. SCHINDLER, Asst. Geologist  
J. O. BRYANT, Asst. Geologist

**SYMBOLS AND ABBREVIATIONS.**  
The symbols and abbreviations used on this map are explained in Chapter II.

**TOWN AND RANGE LINES.**  
In constructing this map the south line of the township was laid off as a true east west line. The other boundary lines were then laid off with the lengths shown on the Land Survey plat. Some of the maps are therefore incorrect in shape but this is necessary because definite facts are lacking. The acreage of part of the lots in the north and west tier of sections is shown to give a check on the distances in these sections.

**LOCATIONS.**  
All locations are based on pacing traverses from government land corners. In many cases these were not found and it was necessary to continue the traverse several miles without a check. Locations of certain features may therefore be somewhat wrong. In such cases the feature sought may best be located by its relation to a stream, swamp, lake, or other feature shown on the map.

**PROFILES.**  
The locations of the profiles are shown on the map by dashed blue lines with black letters at the ends. Railroad profiles were furnished by the companies and show elevations of the ground rather than track in most cases; others are from road surveys by the State Highway Commission; most of them are hand level lines made by this Survey. Wherever possible the elevations above sea level are given. These elevations vary from 1050 to 1770 feet. A local datum plane was necessarily assumed in some cases. These cases are identifiable by the fact that the base line is always numbered 0.

**LAND CLASSIFICATION.**  
This is shown on the map by the blue letters. It is explained in the following township description and at length in chapter V.

**MAGNETIC DATA.**  
Dial compass readings are shown in blue figures. Eastward declinations are shown with a dot to the east and westward with a dot to west of the number. Dip needle readings are shown in black. All are positive except those preceded by the negative sign. All readings show deviation of needles from the normal reading of the instrument used. Normal readings are omitted from the map except at each quarter section corner. All abnormal readings are shown.

Traverses were made on lines indicated—usually the N-S section and quarter lines. Dip needle readings were taken each 50 paces, dial compass readings each 100 paces when sun permitted.

Magnetic lines are indicated by heavy black lines, solid where definite and dashed where doubtful.

**CAUTION:** Almost any kind of rock may be the cause of magnetic attraction. Do not fail to read the following description of this township, and also chapter IV., in which the magnetic attractions are discussed.

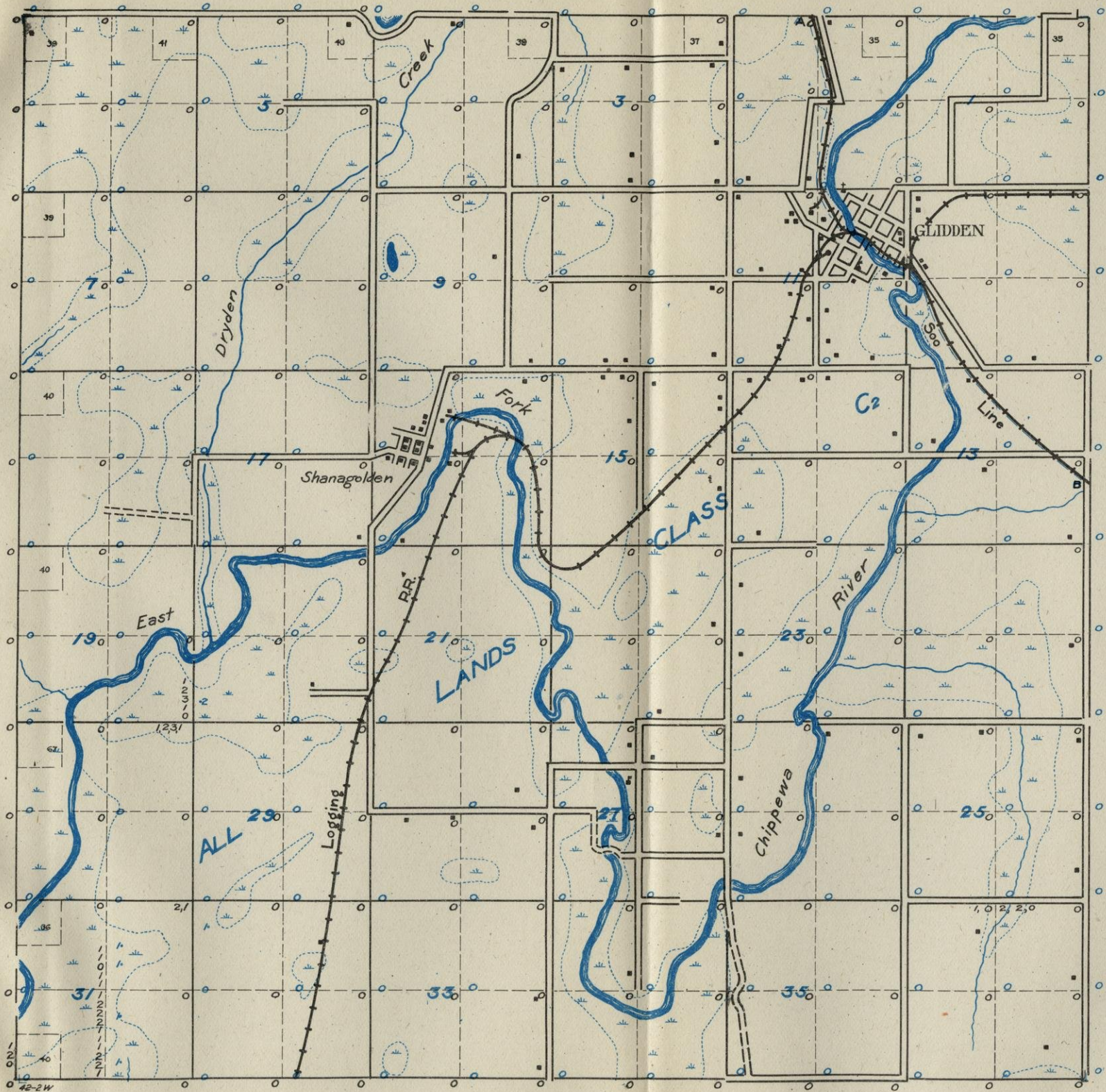

**PROFILE**  
VERTICAL SCALE: 1 space = 20'  
HORIZONTAL SCALE: same as map

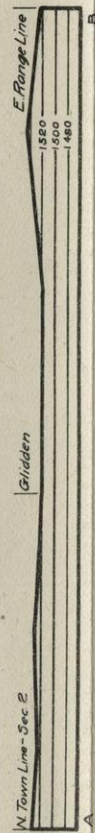

## TOWNSHIP 42 N., RANGE 5 W.

*Surface Features.*—Most of the township presents a rather uneven surface but has only moderate relief and no prominent topographic features. The West Fork of the Chippewa River, which crosses diagonally from northeast to southwest, widens out in a few places to form small lakes and there are a number of ponds and small lakes in the pitted surface of the drift. Large swamp areas exist in the northwestern and southeastern parts of the township where the surface is nearly flat.

There are no roads except old tote roads which are passable with difficulty at all times. Most of the original timber was pine, which has been entirely removed, but a very small amount of hardwood still remains in scattered places. There are no settlers in this township.

*Glacial Drift.*—Terminal moraine of moderately rugged character is found in the east central part and along the west and southwest borders of the township. Outwash is found in small areas in sections 8 and 17 and along the Chippewa River in section 1. The drift in these outwash areas consist almost entirely of sand. The remainder of the township is gently undulating ground moraine. The drift in the terminal and ground moraine areas consists of sand, gravel and boulders, with little silt.

The depth of the drift is uncertain because there are no wells. An exposure of rock in section 23 indicates shallow surface in that part of the township and the depth is thought not to be great at any point.

*General Geology.*—A group of small outcrops was found a short distance north of the S. E. corner of section 23. The exposure is about 200 paces long in an east and west direction and about 50 paces wide. It has no topographic expression and does not extend over 4 feet above its surroundings at any point. The rock varies from a dense hornblende schist on the north side to a granite gneiss on the south side and all gradations between the two are found. Gneissic structure is very well developed throughout. It strikes nearly east and west and dips very steeply to the north. Narrow dikes of granite of a later age cross the outcrops at various angles.

No other exposures were found and it is not possible to make a definite statement as to the character of the rock in the township generally. The general location with reference to other townships

is, however, such as to lead to the belief that Huronian rocks may exist here and if such is the case iron formation is a possibility.

*Magnetic Observations.*—For a general discussion of magnetic observations and their significance, the reader is referred to Chapter V. Much attraction of varying intensity was found in scattered areas over the entire township. It is strongest in the vicinity of Ghost Lake along the west lines of sections 30 and 31, but does not continue either west or southwest into the adjoining townships. For  $1\frac{1}{2}$  miles east milder attraction is found and questionable magnetic lines have been drawn connecting the maximum readings. More detailed work in this locality may indicate an entirely different situation. Several other short magnetic lines are drawn in the map, but in general the attraction is not of such a character as to greatly assist in drawing conclusions as to the geology of this township.

*Land Classification.*—The principles of land classification employed in this work are discussed in Chapter V. Lands in the immediate vicinity of the outcrop of granite gneiss in sections 23 and 24 are placed in class D. All other lands in the township are placed in class C2.

*Exploration.*—Exploration for iron ore cannot be recommended on the basis of present information.

# TOWN 42 N., R. 5W.

Survey Made in August, 1914

Under the Direction of

W. O. HOTCHKISS, State Geologist

AND

E. F. BEAN and O. W. WHEELWRIGHT,  
in charge of Field Parties

BY

J. P. GOLDSBERRY, Chief of Party

C. W. HONESS, Asst. Geologist

T. M. LANGLEY, Asst. Geologist

## SYMBOLS AND ABBREVIATIONS.

The symbols and abbreviations used on this map are explained in Chapter II.

## TOWN AND RANGE LINES.

In constructing this map the south line of the township was laid off as a true east west line. The other boundary lines were then laid off with the lengths shown on the Land Survey plat. Some of the maps are therefore incorrect in shape but this is necessary because definite facts are lacking. The acreage of part of the lots in the north and west tier of sections is shown to give a check on the distances in these sections.

## LOCATIONS.

All locations are based on pacing traverses from government land corners. In many cases these were not found and it was necessary to continue the traverse several miles without a check. Locations of certain features may therefore be somewhat wrong. In such cases the feature sought may best be located by its relation to a stream, swamp, lake, or other feature shown on the map.

## PROFILES.

The locations of the profiles are shown on the map by dashed blue lines with black letters at the ends. Railroad profiles were furnished by the companies and show elevations of the ground rather than track in most cases; others are from road surveys by the State Highway Commission: most of them are hand level lines made by this Survey. Wherever possible the elevations above sea level are given. These elevations vary from 1050 to 1770 feet. A local datum plane was necessarily assumed in some cases. These cases are identifiable by the fact that the base line is always numbered 0.

## LAND CLASSIFICATION.

This is shown on the map by the blue letters. It is explained in the following township description and at length in chapter V.

## MAGNETIC DATA.

Dial compass readings are shown in blue figures. Eastward declinations are shown with a dot to the east and westward with a dot to west of the number. Dip needle readings are shown in black. All are positive except those preceded by the negative sign. All readings show deviation of needles from the normal reading of the instrument used. Normal readings are omitted from the map except at each quarter section corner. All abnormal readings are shown.

Traverses were made on lines indicated—usually the N-S section and quarter lines. Dip needle readings were taken each 50 paces, dial compass readings each 100 paces when sun permitted.

Magnetic lines are indicated by heavy black lines, solid where definite and dashed where doubtful.

**CAUTION:** Almost any kind of rock may be the cause of magnetic attraction. Do not fail to read the following description of this township, and also chapter IV., in which the magnetic attractions are discussed.

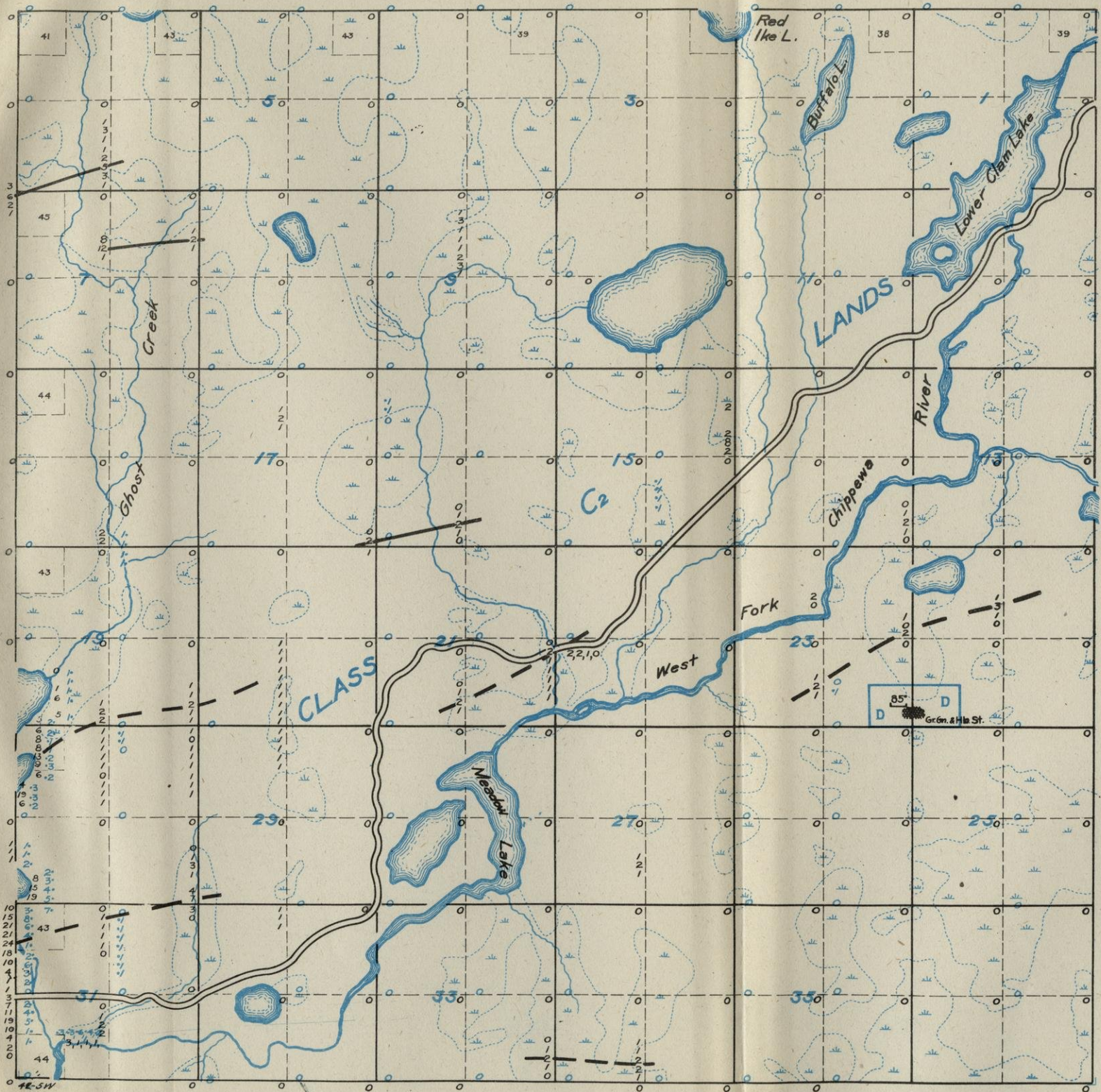

## TOWNSHIP 42 N., RANGE 6 W.

*Surface Features.*—The **entire** township is characterized by a rather roughly undulating **surface**. Most of the level ground is occupied by swamps. There is a large number of lakes, most of which are characterized by **extremely** irregular shore lines.

This township is practically **without** roads, but the summer resorts on Teal Lake are reached by a fair road from the township to the south. Mixed timber, principally hemlock, is found in sections 23, 24, 25, 26, 34, 35 and 36 and in small patches in sections 12 and 13. The remainder of the township was timbered largely by pine which has all been removed. With the exception of one farmer living in section 31, the only people in the township are the owners of summer resorts on the lakes.

*Glacial Drift.*—The glacial drift of the entire township is terminal moraine which varies from markedly rugged knob and kettle type to roughly undulating. The drift consists of sand, gravel and boulders, the surface being characteristically sandy. A well at Ghost Lake in the southeast corner of the township is reported to have encountered clay at a depth of 27 feet.

There is no information upon which to base an estimate of the thickness of the drift other than the general character of the deposits, but it is believed that the rocks are deeply buried.

There are no rock exposures in this township and none of the adjoining townships which give a definite idea of the character of the underlying rocks. The township is believed to be underlain by Huronian rocks because of its location between townships known more definitely to contain rocks of this age. Some igneous rocks are probably present, however.

*Magnetic Observations.*—For a general discussion of magnetic observations and their significance, the reader is referred to Chapter IV. While mild positive and negative dip needle readings were found in several localities, the information is not of such a nature as to be of great assistance in working out the geology of this township. Strong attractions are found in the extreme southeastern corner and continue in an indefinite way in T. 42—5 W. They are discussed in the report on that township. Negative readings such as found here are usually taken as an indication of igneous rocks but an exception is made in this instance because of the relation of these attractions to a strong negative belt in T. 41—7 W. believed to be caused by sedimentary rocks.

*Land Classification.*—The principles of land classification employed in this work are discussed in Chapter V. All lands are placed in class C2, for lack of information upon which to base a more detailed classification.

*Exploration.*—Exploration cannot be recommended on the information at present available unless an iron formation is developed in one of the adjoining townships and traced to this one.



TOWN 42 N., R. 6W.

Survey Made in October, 1914

Under the Direction of

W. O. HOTCHKISS, State Geologist

AND

E. F. BEAN and O. W. WHEELWRIGHT,  
in charge of Field Parties

BY

J. P. GOLDSBERRY, Chief of Party

O. W. POTTER, Asst. Geologist

HOWARD QUINLAN, Asst. Geologist

SYMBOLS AND ABBREVIATIONS.

The symbols and abbreviations used on this map are explained in Chapter II.

TOWN AND RANGE LINES.

In constructing this map the south line of the township was laid off as a true east west line. The other boundary lines were then laid off with the lengths shown on the Land Survey plat. Some of the maps are therefore incorrect in shape but this is necessary because definite facts are lacking. The acreage of part of the lots in the north and west tier of sections is shown to give a check on the distances in these sections.

LOCATIONS.

All locations are based on pacing traverses from government land corners. In many cases these were not found and it was necessary to continue the traverse several miles without a check. Locations of certain features may therefore be somewhat wrong. In such cases the feature sought may best be located by its relation to a stream, swamp, lake, or other feature shown on the map.

PROFILES.

The locations of the profiles are shown on the map by dashed blue lines with black letters at the ends. Railroad profiles were furnished by the companies and show elevations of the ground rather than track in most cases; others are from road surveys by the State Highway Commission; most of them are hand level lines made by this Survey. Wherever possible the elevations above sea level are given. These elevations vary from 1050 to 1770 feet. A local datum plane was necessarily assumed in some cases. These cases are identifiable by the fact that the base line is always numbered 0.

LAND CLASSIFICATION.

This is shown on the map by the blue letters. It is explained in the following township description and at length in chapter V.

MAGNETIC DATA.

Dial compass readings are shown in blue figures. Eastward declinations are shown with a dot to the east and westward with a dot to west of the number. Dip needle readings are shown in black. All are positive except those preceded by the negative sign. All readings show deviation of needles from the normal reading of the instrument used. Normal readings are omitted from the map except at each quarter section corner. All abnormal readings are shown.

Traverses were made on lines indicated—usually the N-S section and quarter lines. Dip needle readings were taken each 50 paces, dial compass readings each 100 paces when sun permitted.

Magnetic lines are indicated by heavy black lines, solid where definite and dashed where doubtful.

CAUTION: Almost any kind of rock may be the cause of magnetic attraction. Do not fail to read the following description of this township, and also chapter IV., in which the magnetic attractions are discussed.

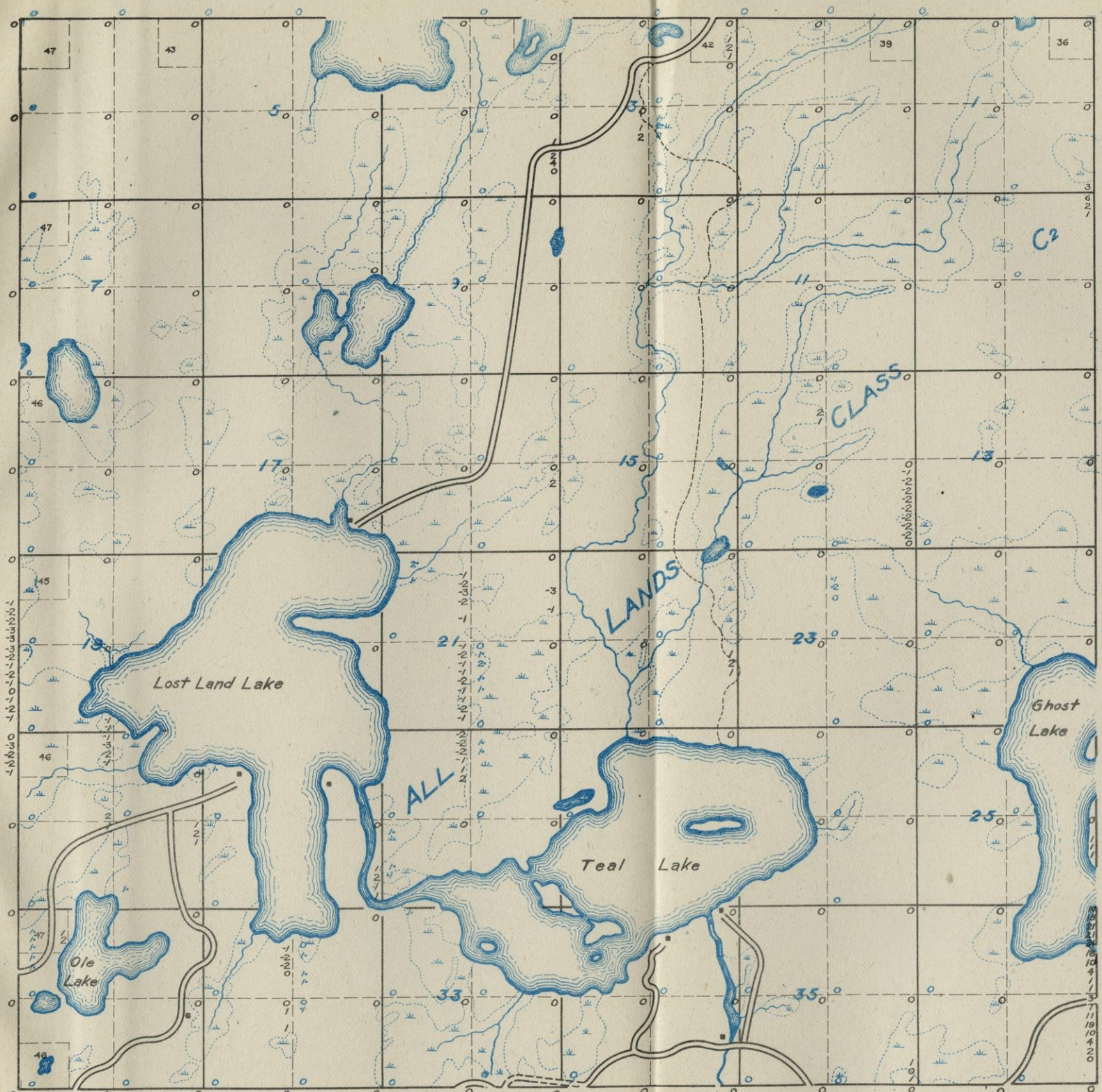

## TOWNSHIP 42 N., RANGE 7 W.

*Surface Features.*—North of a line drawn from the southwest corner of section 19, to the east quarter post of section 17, then to the southeast corner of the township, the country is rugged with a relief varying from 50 to over 200 feet. Numerous small lakes dot the surface but swamp areas are relatively few except in the east central part. South of this line the country is more level, although in sections 31 and 32 the surface is considerably pitted, giving it a rugged appearance. The higher ground is all about the same level. Swamps are not numerous or large here.

A large number of old tote roads follow winding courses through this township. They are passable because they are sandy. There are some farmers in the southwestern part, and some graded roads have been built in that section. Very little timber of consequence remains but scattered patches of hardwood and hemlock are found in many parts.

*Glacial Drift.*—The rugged northern area is terminal moraine of a very pronounced type except in the east central part, where the terminal characteristics are much less prominent. The drift consists of sand, gravel and boulders, with minor amounts of silt in some places. Boulders are frequently found in very large quantities. The remainder of the township is outwash, somewhat rough, and containing a few boulders along the edge of the terminal moraine, and very much pitted in sections 31 and 32. The drift consists of sand and gravel.

There is nothing to indicate the depth of the surface but it is believed to be great over the entire township.

*General Geology.*—There are no exposures in this township or in the adjacent townships to give information bearing on the character of the underlying rock. The only guides to the geology are magnetic data and general location, from which it is concluded that sections 5, 6, 7 and 18 are probably underlain by the Keweenaw traps and the remainder of the township by Huronian formations. It is extremely probable that igneous rocks will be found in some places in the area mapped as Huronian.

*Magnetic Observations.*—A general discussion of magnetic observations and their significance is given in Chapter IV. Mild abnormal dip needle readings are obtained on nearly all lines of traverse in the northwest part and it is thought that these indicate the presence of

Keweenawan traps. Scattered irregularly over the remainder of the township are mild attractions, usually negative in character. They are less readily explained than those in the northwestern part, but are thought possibly to be due to intrusives into the Huronian. On the maps some questionable magnetic lines have been drawn connecting positive maximum readings in this area.

*Land Classification.*—The principles of land classification employed in this work are discussed in Chapter V. Lands supposed to be underlain by Keweenawan traps are placed in class D. Because of the lack of exposures it is not absolutely certain that the trap rock underlies this area but the evidence is sufficiently strong to warrant using this classification. All other lands are placed in class C2.

*Exploration.*—Exploration for iron ore in this township cannot be recommended on the basis of present information.

**TOWN 42 N., R. 7W.**  
Survey Made in October, 1914

Under the Direction of  
**W. O. HOTCHKISS, State Geologist**  
AND  
**E. F. BEAN and O. W. WHEELWRIGHT,**  
in charge of Field Parties  
BY  
**J. P. GOLDSBERRY, Chief of Party**  
**G. S. NISHIHARA, Asst. Geologist**

**SYMBOLS AND ABBREVIATIONS.**  
The symbols and abbreviations used on this map are explained in Chapter II.

**TOWN AND RANGE LINES.**  
In constructing this map the south line of the township was laid off as a true east west line. The other boundary lines were then laid off with the lengths shown on the Land Survey plat. Some of the maps are therefore incorrect in shape but this is necessary because definite facts are lacking. The acreage of part of the lots in the north and west tier of sections is shown to give a check on the distances in these sections.

**LOCATIONS.**  
All locations are based on pacing traverses from government land corners. In many cases these were not found and it was necessary to continue the traverse several miles without a check. Locations of certain features may therefore be somewhat wrong. In such cases the feature sought may best be located by its relation to a stream, swamp, lake, or other feature shown on the map.

**PROFILES.**  
The locations of the profiles are shown on the map by dashed blue lines with black letters at the ends. Railroad profiles were furnished by the companies and show elevations of the ground rather than track in most cases; others are from road surveys by the State Highway Commission: most of them are hand level lines made by this Survey. Wherever possible the elevations above sea level are given. These elevations vary from 1050 to 1770 feet. A local datum plane was necessarily assumed in some cases. These cases are identifiable by the fact that the base line is always numbered 0.

**LAND CLASSIFICATION.**  
This is shown on the map by the blue letters. It is explained in the following township description and at length in chapter V.

**MAGNETIC DATA.**  
Dial compass readings are shown in blue figures. Eastward declinations are shown with a dot to the east and westward with a dot to west of the number. Dip needle readings are shown in black. All are positive except those preceded by the negative sign. All readings show deviation of needles from the normal reading of the instrument used. Normal readings are omitted from the map except at each quarter section corner. All abnormal readings are shown.

Traverses were made on lines indicated—usually the N-S section and quarter lines. Dip needle readings were taken each 50 paces, dial compass readings each 100 paces when sun permitted.

Magnetic lines are indicated by heavy black lines, solid where definite and dashed where doubtful.

**CAUTION:** Almost any kind of rock may be the cause of magnetic attraction. Do not fail to read the following description of this township, and also chapter IV., in which the magnetic attractions are discussed.

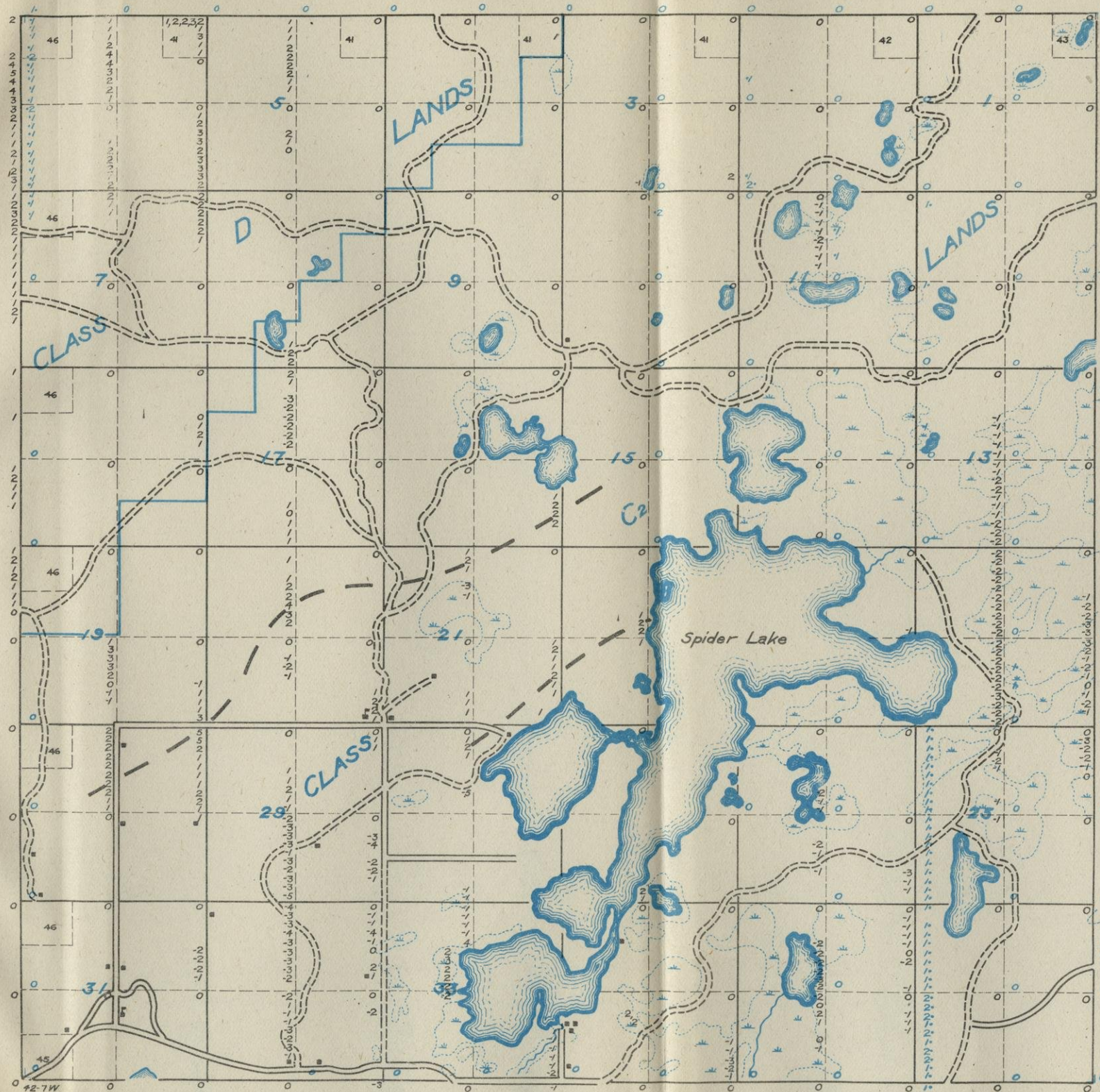

## TOWNSHIP 42 N., RANGE 8 W.

*Surface Features.*—East of a line extending from the northwest corner of section 1 to the southwest corner of section 33 the topography is very roughly undulating. To the west of this is a sandy plain, averaging about 2 miles in width, through which the Namakagon River flows. West of this plain is a belt of rough topography averaging less than a mile in width. The northwestern part of the township is level to gently undulating.

Profiles A-B and C-D are typical of the plain which slopes gently southward. The minor irregularities are pits or stream channels. Most of the settlement is in the plain or gently undulating country. Here the roads are good. There is but little timber left in the township.

*Glacial Drift.*—The central plain is outwash. In places on either side of the river and about  $\frac{1}{4}$  of a mile distant there are terrace fronts which were the banks of the Namakagon River in glacial times. The road in the northwest part of section 16 follows the foot of one of these terrace fronts. Terminal moraine covers all of the township east of the outwash plain. There is an abrupt rise of from 80 to 125 feet from the plain to the tops of the hills. In this moraine there are numerous deep kettles with very steep sides. West of the outwash plain is another belt of rough terminal moraine averaging little less than a mile in width, and northwest of this terminal is an area of gently undulating ground moraine with swamps in the depressions. The west front of the eastern terminal moraine is so steep as to suggest that rock influences the topography, and that the Namakagon River flows in an outwash-filled pre-glacial valley.

The glacial deposits are sand, with a small percentage of silt, in the outwash; sand, gravel, silt and boulders in the terminal moraine; sand, silt and boulders in the ground moraine.

The thickness of drift is not definitely known. If the Namakagon occupies a pre-glacial valley, and the highlands to the east and west are rock cored, the drift is thick in the outwash area and relatively thin in the highlands. However, as the local relief in the eastern highland is as much as 80 feet in some places and there are no known exposures of ledge, it seems likely that the drift cover is quite heavy. The relief is not so great in the upland west of the Namakagon plain, and it may be assumed that the drift cover is somewhat thinner.

*General Geology.*—There are no exposures of rock in this township and the geology is mapped entirely from information obtained from magnetic work in this and the adjoining townships. It is believed that the Keweenawan traps underlie all of the township except a few sections in the southeast corner. The approximate boundary is indicated on the map by the land classification line. The underlying rock in this southeastern corner may be either Huronian sediments or granites.

*Magnetic Observations.*—A general discussion of magnetic observations and their significance is given in Chapter IV. Very mild attraction was found over most of the township, as shown on the map. Where readings are the same across a forty acre tract this fact is indicated by readings at each of the corners to avoid crowding on the map. This attraction is believed to be caused by the Keweenawan trap rocks.

*Land Classification.*—A general discussion of the principles of land classification employed in this work is given in Chapter V. All lands in the area of trap rocks are placed in class D. Others are placed in class C2 because iron formation is considered a possibility, although there are no indications of its presence.

*Exploration.*—Exploration for iron ore in this township is not recommended.

TOWN 42 N., R. 8W.

Survey Made in September, 1914

Under the Direction of

W. O. HOTCHKISS, State Geologist

AND

E. F. BEAN and O. W. WHEELWRIGHT,  
in charge of Field Parties

BY

T. M. BRODERICK, Chief of Party

H. N. EIDEMILLER, Asst. Geologist

F. R. PRETYMAN, Asst. Geologist

SYMBOLS AND ABBREVIATIONS.

The symbols and abbreviations used on this map are explained in Chapter II.

TOWN AND RANGE LINES.

In constructing this map the south line of the township was laid off as a true east west line. The other boundary lines were then laid off with the lengths shown on the Land Survey plat. Some of the maps are therefore incorrect in shape but this is necessary because definite facts are lacking. The acreage of part of the lots in the north and west tier of sections is shown to give a check on the distances in these sections.

LOCATIONS.

All locations are based on pacing traverses from government land corners. In many cases these were not found and it was necessary to continue the traverse several miles without a check. Locations of certain features may therefore be somewhat wrong. In such cases the feature sought may best be located by its relation to a stream, swamp, lake, or other feature shown on the map.

PROFILES.

The locations of the profiles are shown on the map by dashed blue lines with black letters at the ends. Railroad profiles were furnished by the companies and show elevations of the ground rather than track in most cases; others are from road surveys by the State Highway Commission: most of them are hand level lines made by this Survey. Wherever possible the elevations above sea level are given. These elevations vary from 1050 to 1770 feet. A local datum plane was necessarily assumed in some cases. These cases are identifiable by the fact that the base line is always numbered 0.

LAND CLASSIFICATION.

This is shown on the map by the blue letters. It is explained in the following township description and at length in chapter V.

MAGNETIC DATA.

Dial compass readings are shown in blue figures. Eastward declinations are shown with a dot to the east and westward with a dot to west of the number. Dip needle readings are shown in black. All are positive except those preceded by the negative sign. All readings show deviation of needles from the normal reading of the instrument used. Normal readings are omitted from the map except at each quarter section corner. All abnormal readings are shown.

Traverses were made on lines indicated—usually the N-S section and quarter lines. Dip needle readings were taken each 50 paces, dial compass readings each 100 paces when sun permitted.

Magnetic lines are indicated by heavy black lines, solid where definite and dashed where doubtful.

CAUTION: Almost any kind of rock may be the cause of magnetic attraction. Do not fail to read the following description of this township, and also chapter IV., in which the magnetic attractions are discussed.

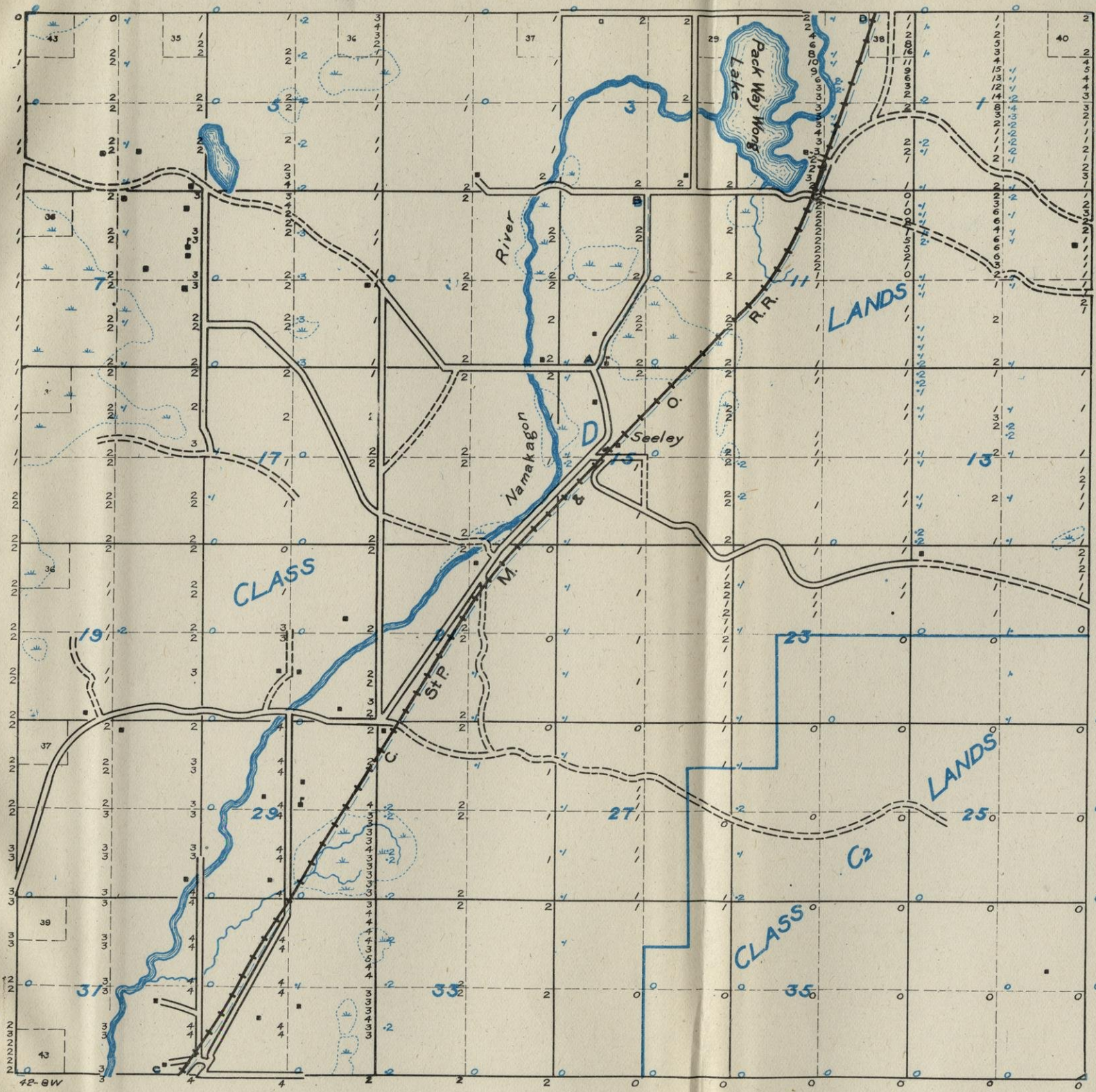

PROFILES

VERTICAL SCALE: 1 space = 20'  
HORIZONTAL SCALE: same as map.

LOCAL DATUM  
1/4 M. W. of 1/4 Cor. Secs. 3-10  
1/4 M. E. of 1/4 Cor. Secs. 10-15

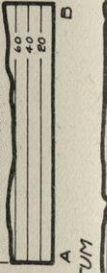

SEA LEVEL DATUM

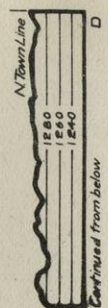

Seeley

Coon Creek

Town Line

Continued above

## TOWNSHIP 43 N., RANGE 2 W.

*Surface Features.*—This township drains into two great river systems. Part of its drainage goes southward through the Chippewa River to the Mississippi, and part goes northward through the Bad River to Lake Superior. There is no distinct topographic feature marking the divide, but merely a broad area of poor drainage. The western and northern parts of the township are high and the topography is in general gently undulating. The numerous rock outcrops in the north seem to indicate that rock dominates the topography. The remainder of the township is a level to gently undulating plain out of which rise numerous sand and gravel ridges.

Profile C-D is characteristic of the plain in the central part of the township and shows the character of the topography in the divide area. In profile D-E is shown the northern highland rising about 1,540 feet above sea level, with valleys cut 50 to 80 feet below this level. Profile C-F shows the highland in section 30 rising to a height of 1,645 feet above sea level and nearly 100 feet above the broad swampy plain to the east. In profile N-P is shown typical moraine ridges in parts of sections 2, 11, 1 and 12. Profile L-M shows the swampy valley followed by the railroad with terminal ridges to the east and west.

Except in the northwestern part most of the roads are very good. There are areas of good hardwood timber in the northwest, north central, west central and southeastern parts of the township. Farming is well developed in the south central part.

*Glacial Drift.*—The northern and eastern parts are ground moraine in which the topography is determined in large measure by granite which outcrops in many places. Outside of this area of rock dominated topography is a sandy outwash plain with terminal moraine ridges rising above it. A large part of the outwash is covered by swamp.

The glacial deposits are sand, silt and boulders in the ground moraine; sand, gravel and boulders in the terminal moraine; sand, and gravel with a small amount of silt, in the outwash.

The drift cover in the northern part of the township is certainly thin as outcrops are numerous. In the southern part most of the wells are shallow and none are known which penetrate the ledge. The average thickness of drift in the southern part of the township is probably not over 75 feet.



*General Geology.*—Over the northern third of this township are numerous outcrops of granite gneiss with occasional dikes of diorite, diabase, and pegmatites. The color of the granite varies from gray to pink and the texture from very fine grained to rather coarse porphyritic granite with feldspar crystals about an inch in length. The pegmatites are still coarser. Biotite is very largely developed in most of the places where the rocks are exposed. One rather isolated outcrop of this granite occurs in section 14. There is nothing to definitely indicate the character of the underlying rock in the southern half of the township but it is believed that granites will also be found here.

*Magnetic Observations.*—A general discussion of magnetic observations and their significance is given in Chapter IV. One very mild irregular local attraction is found in this township and its character is such as to lead to the belief that it is not caused by iron formation.

*Land Classification.*—The principles of land classification employed in this work are discussed in Chapter V. That part of the township in which the granite outcrops are of common occurrence are placed in class D, of no probable value as mineral land. In this classification is also indicated the S. W.  $\frac{1}{4}$  of section 14. Possibly all the township should be included in the D lands, but lack of outcrops in the southern two-thirds makes it advisable to place the lands in this part in class C2.

*Exploration.*—Exploration in this township is not recommended.



## TOWNSHIP 43 N., RANGE 4 W.

*Surface Features.*—Nearly all of this township has an undulating surface although some flat areas of small extent are found. Along the west line it is especially rough. The surface is covered with numerous swamps many of which are of large size and small lakes are of frequent occurrence. The central part of the township serves as a divide between the drainage of the Mississippi River and that of Lake Superior.

The township is very poorly supplied with roads and such as exist are old tote roads fit for travel only because of the fact that they cross sandy country. Considerable quantities of timber still remain uncut. It is principally hemlock with some hardwood and is found in all parts of the township except the southwestern quarter. There are no settlers.

*Glacial Drift.*—The glacial drift consists of sand, gravel and boulders with but very minor amounts of silt. The surface is characteristically sandy and the boulders are very numerous in many places.

*General Geology.*—There are no rock exposures in this township and the geological formations can be mapped only on the evidence obtained from magnetic work and from the general location with reference to other areas where information is available. It is believed that the township is in an area of Huronian rocks and the chances for finding an iron formation are good.

*Magnetic Observations.*—A general discussion of magnetic observations and their significance is given in Chapter IV. Magnetic attraction was found in the northern two-thirds of the township on every traverse, varying from strongly negative to strongly positive abnormal readings. As a rule the attractions are irregular in character and definite magnetic lines cannot be drawn. In sections 14 and 15 there is a suggestion of an anticlinal fold pitching westward, the formation following a course about as indicated by the dashed line. Much more detailed work would, however, be necessary to make certain of this and it is possible that a different conclusion might be reached when closer spaced traverses are made.

*Land Classification.*—A general discussion of the principles of land classification employed in this work is given in Chapter V. Lands in the general area of stronger attraction in the east central part of the township are placed in class C1. All others are placed in

class C2 but it is very probable that when explorers enter this township some of these will be found to be worthy of higher classification.

*Exploration.*—The first step in exploring this township should be a careful magnetic survey with runs at much closer intervals than are shown on the map. The formation should be followed by crossing and re-crossing the maximum line and traced as far as possible by means of the dip needle and dial compass. The results of such a detailed magnetic survey should determine whether the more expensive methods of exploring are advisable. Much of the work done in exploration for iron ore is wasted because of failure to make intelligent use of the geologic and magnetic data to be obtained by a careful preliminary survey, and because the geologic information given by the drill is not properly used as a guide for further work. The value of careful scientific methods of exploration therefore cannot be too strongly emphasized. If exploration is contemplated in this township the discussion of this subject in Chapter VI should be carefully studied.

# TOWN 43 N., R. 4W.

Survey Made in September, 1914.

Under the Direction of  
W. O. HOTCHKISS, State Geologist  
AND  
E. F. BEAN and O. W. WHEELWRIGHT,  
in charge of Field Parties  
BY

J. P. GOLDSBERRY, Chief of Party  
C. W. HONESS, Asst. Geologist  
T. M. LANGLEY, Asst. Geologist

**SYMBOLS AND ABBREVIATIONS.**  
The symbols and abbreviations used on this map are explained in Chapter II.

**TOWN AND RANGE LINES.**  
In constructing this map the south line of the township was laid off as a true east west line. The other boundary lines were then laid off with the lengths shown on the Land Survey plat. Some of the maps are therefore incorrect in shape but this is necessary because definite facts are lacking. The acreage of part of the lots in the north and west tier of sections is shown to give a check on the distances in these sections.

**LOCATIONS.**  
All locations are based on pacing traverses from government land corners. In many cases these were not found and it was necessary to continue the traverse several miles without a check. Locations of certain features may therefore be somewhat wrong. In such cases the feature sought may best be located by its relation to a stream, swamp, lake, or other feature shown on the map.

**PROFILES.**  
The locations of the profiles are shown on the map by dashed blue lines with black letters at the ends. Railroad profiles were furnished by the companies and show elevations of the ground rather than track in most cases; others are from road surveys by the State Highway Commission; most of them are hand level lines made by this Survey. Wherever possible the elevations above sea level are given. These elevations vary from 1050 to 1770 feet. A local datum plane was necessarily assumed in some cases. These cases are identifiable by the fact that the base line is always numbered 0.

**LAND CLASSIFICATION.**  
This is shown on the map by the blue letters. It is explained in the following township description and at length in chapter V.

**MAGNETIC DATA.**  
Dial compass readings are shown in blue figures. Eastward declinations are shown with a dot to the east and westward with a dot to west of the number. Dip needle readings are shown in black. All are positive except those preceded by the negative sign. All readings show deviation of needles from the normal reading of the instrument used. Normal readings are omitted from the map except at each quarter section corner. All abnormal readings are shown.

Traverses were made on lines indicated—usually the N-S section and quarter lines. Dip needle readings were taken each 50 paces, dial compass readings each 100 paces when sun permitted.

Magnetic lines are indicated by heavy black lines, solid where definite and dashed where doubtful.

**CAUTION:** Almost any kind of rock may be the cause of magnetic attraction. Do not fail to read the following description of this township, and also chapter IV., in which the magnetic attractions are discussed.

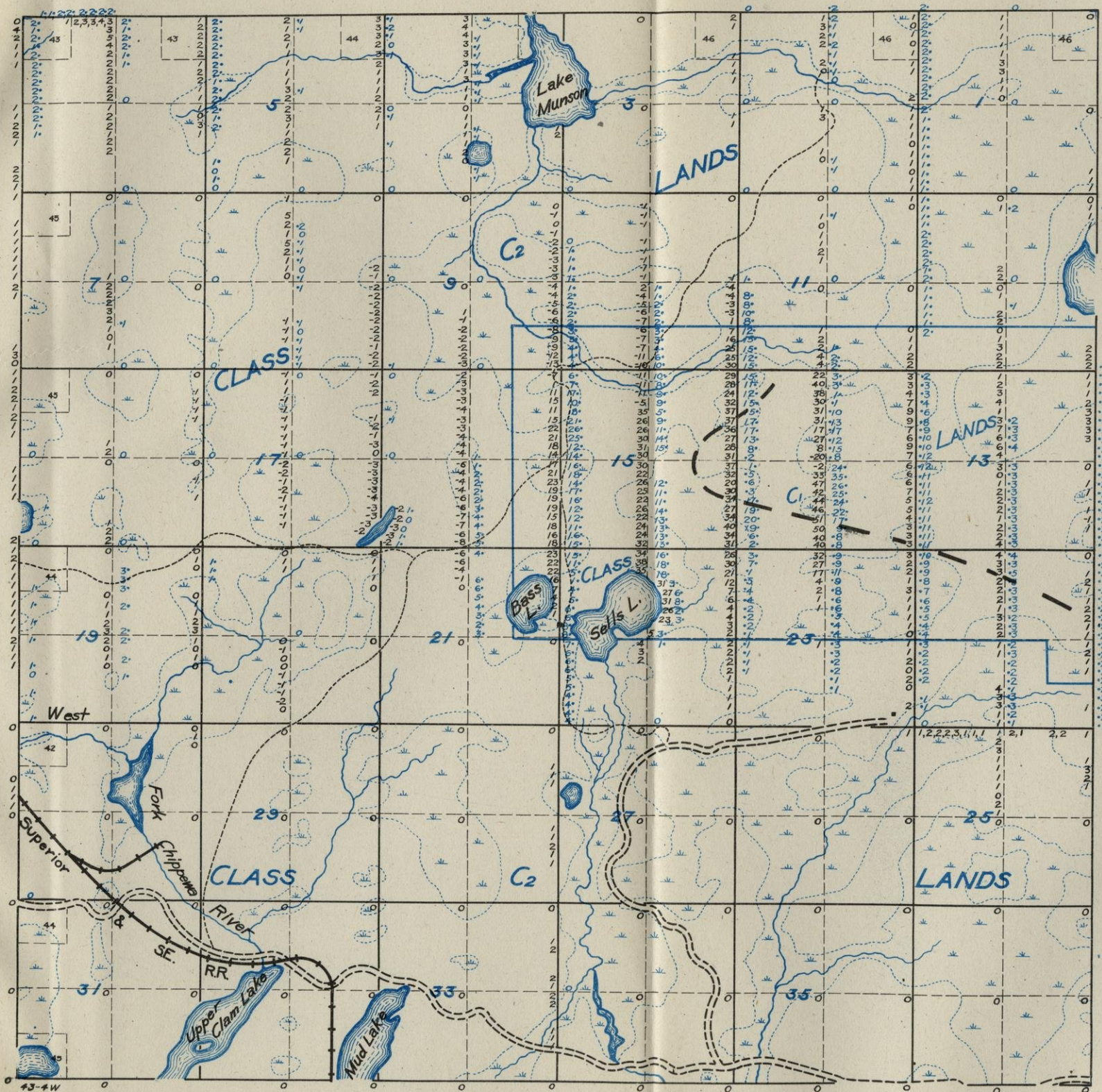

## TOWNSHIP 43 N., RANGE 5 W.

*Surface Features.*—All of the south half of the township has a rough surface and very pronounced relief except an area of about 4 sections in the southwest corner. Numerous small lakes and swamps fill the depressions in the drift. A narrow belt of hilly country extends across the northern half of sections 9, 10 and 11 and through the center of section 2. In the remainder of the township the surface is more gently undulating, lakes are less common and swamps are much larger.

The only roads which exist are old tote roads which are very little used and in poor condition. Large quantities of timber still remain, especially in those parts of the township along the logging railroads. In it is principally hemlock with some mixed hardwood. There are no settlers.

*Glacial Drift.*—A broad terminal moraine occupies most of the southern half of the township. The moraine is partly of the knob and kettle type and partly the roughly undulating type, but the terminal characteristics are not pronounced except at a few places. Another narrow strip of terminal moraine varying in width from  $\frac{1}{4}$  to  $\frac{1}{2}$  mile extends east from the center of section 9 to the northwest corner of section 11 where there is a bend to the north across section 2. The remainder of the township is ground moraine covered to some extent by outwash. It has a gently undulating surface. Outwash was identified in the west side of section 23, the west side of section 29, and over a rather more extensive area in sections 5, 6, 7 and 8. The drift in the terminal moraines consists of sand, gravel and boulders. Many of the latter attain a size of from 6 to 8 feet in diameter. The outwash is sand and gravel with but very few boulders. The ground moraine is somewhat less sandy and contains boulders in large numbers.

There are no wells in the township and but one rock exposure, so that information bearing on the depth of drift is very meager. The drift is probably only of moderate thickness in the ground moraine and the outwash areas, but is thought to exceed 100 feet in all the terminal moraine.

*General Geology.*—An outcrop of granite occurs at the northwest corner of section 1, but no other exposures were found. The rock is a very fine-grained granite gneiss composed essentially of feldspar, both orthoclase and plagioclase, quartz, and biotite. Crystals are seldom more than a small fraction of an inch in diameter. This granite is

probably Archean in age. The geology of the township as a whole must be mapped from magnetic evidence and its relations to the adjoining townships. Very coarse basic igneous rocks occur in the northeastern part of the township west and magnetic attractions indicate that they may extend over into sections 5, 6 and 7. It is impossible to state what rocks underlie the remainder of the township but the occurrence of Huronian formations is thought probable.

*Magnetic Observations.*—A general discussion of magnetic observations and their significance is given in Chapter IV. Scattered areas of attraction were found over the entire northern two-thirds of the township. That in sections 5, 6 and 7 is probably caused by the basic igneous intrusives which outcrop a mile to the west. A somewhat doubtful line extends across sections 17 and 18 but it is in an area of irregular attractions which may also be due to igneous rocks. However, there is a chance that it may be caused by iron formation.

*Land Classification.*—A general discussion of the principles of land classification employed in this work is given in Chapter V. The two forty-acre tracts upon which granite occurs are also placed in class D. All other lands are placed in class C2, because they are considered as worthy of further examination. The presence of igneous intrusives in the northwestern part is not sufficiently certain to warrant using the D classification.

*Exploration.*—Exploration in this township, independent of work to the northeast and southwest, is not advised at present. The history of iron mining shows that practically all ranges are developed at some points showing positive indications and later extended to areas which in themselves show nothing to indicate the presence of ore. This township lies between two areas showing these positive indications. The reader should study the reports on the townships to the northeast and southwest, and Chapter VI which gives a general discussion of exploration methods.

# TOWN 43 N., R. 5W.

Survey Made in September, 1914

Under the Direction of

W. O. HOTCHKISS, State Geologist

AND  
E. F. BEAN and O. W. WHEELWRIGHT,  
in charge of Field Parties

BY

J. P. GOLDSBERRY, Chief of Party

T. M. LANGLEY, Asst. Geologist

G. S. NISHIHARA, Asst. Geologist

W. H. HERBERT, Asst. Geologist

## SYMBOLS AND ABBREVIATIONS.

The symbols and abbreviations used on this map are explained in Chapter II.

## TOWN AND RANGE LINES.

In constructing this map the south line of the township was laid off as a true east west line. The other boundary lines were then laid off with the lengths shown on the Land Survey plat. Some of the maps are therefore incorrect in shape but this is necessary because definite facts are lacking. The acreage of part of the lots in the north and west tier of sections is shown to give a check on the distances in these sections.

## LOCATIONS.

All locations are based on pacing traverses from government land corners. In many cases these were not found and it was necessary to continue the traverse several miles without a check. Locations of certain features may therefore be somewhat wrong. In such cases the feature sought may best be located by its relation to a stream, swamp, lake, or other feature shown on the map.

## PROFILES.

The locations of the profiles are shown on the map by dashed blue lines with black letters at the ends. Railroad profiles were furnished by the companies and show elevations of the ground rather than track in most cases; others are from road surveys by the State Highway Commission: most of them are hand level lines made by this Survey. Wherever possible the elevations above sea level are given. These elevations vary from 1050 to 1770 feet. A local datum plane was necessarily assumed in some cases. These cases are identifiable by the fact that the base line is always numbered 0.

## LAND CLASSIFICATION.

This is shown on the map by the blue letters. It is explained in the following township description and at length in chapter V.

## MAGNETIC DATA.

Dial compass readings are shown in blue figures. Eastward declinations are shown with a dot to the east and westward with a dot to west of the number. Dip needle readings are shown in black. All are positive except those preceded by the negative sign. All readings show deviation of needles from the normal reading of the instrument used. Normal readings are omitted from the map except at each quarter section corner. All abnormal readings are shown.

Traverses were made on lines indicated—usually the N-S section and quarter lines. Dip needle readings were taken each 50 paces, dial compass readings each 100 paces when sun permitted.

Magnetic lines are indicated by heavy black lines, solid where definite and dashed where doubtful.

**CAUTION:** Almost any kind of rock may be the cause of magnetic attraction. Do not fail to read the following description of this township, and also chapter IV., in which the magnetic attractions are discussed.

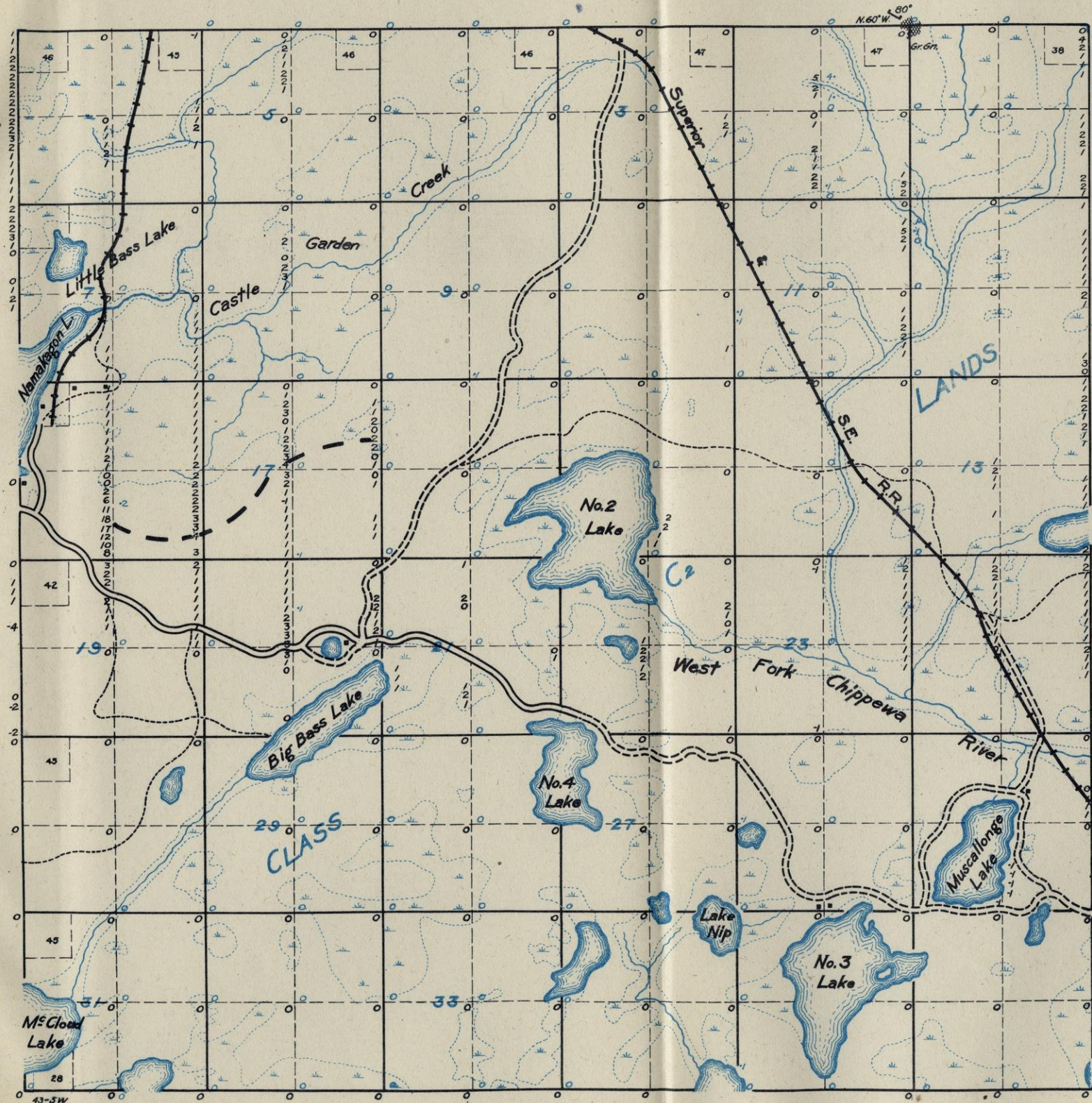



## TOWNSHIP 43 N., RANGE 6 W.

*Surface Features.*—An area of moderately rough topography extends across the south half of the township, varying in width from 1 mile to over 2 miles. It is characterized by steep slopes, knob-like hills, and numerous rounded depressions. The relief sometimes reaches as much as 150 feet. The remainder of the township is characterized by relatively flat surface which is, however, somewhat pitted in places. There are many small lakes and one large one, Lake Namakagon, which winds around in the lower places of the level northern half of the township. The northern half also contains a number of swamps of considerable size.

The old tote roads built in the logging days are the only roads in the township, but owing to the sandy nature of the country they are in fairly good shape for travel. Most of the township was originally covered with pine, all of which has been removed. A small amount of hemlock and hardwood still remain in the northeastern quarter. There are a few settlers around Lake Namakagon.

*Glacial Drift.*—The rough area crossing the south half of the township is very typical terminal moraine and is part of a moraine extending east and west across several townships. The remainder of the township is ground moraine and outwash, which are not readily differentiated. Most of it is fairly free from bowlders. Ground moraine surrounds Lake Namakagon but most of the remainder of the flat area is outwash. The drift is sand, gravel and bowlders in the ground and terminal moraine and sand and gravel in the outwash.

Outcrops in the northwest and northeastern corners suggest comparatively shallow surface for the ground moraine and outwash areas. In the terminal moraine the depth of the drift is probably more than 100 feet.

*General Geology.*—Exposures of rock occur in two localities in this township; in the northern part of sections 1 and 2, and in sections 5, 6 and 7 principally along the west line of section 6. The outcrops are all rather low and inconspicuous but, especially in section 1, are readily seen in traversing the country. In the northeastern area the exposures show a coarse grained basic rock composed almost entirely of pyroxene. This is apparently Keweenawan in age and judging from the results of the work done by early geological surveys<sup>1</sup> in this vicinity is intrusive into rocks of Huronian age. In

<sup>1</sup>Geology of Wisconsin, Vol. III.

the northwestern part of the township the rock varies from a fine-grained basalt to a medium grained diabase. In places the basalts are amygdaloidal. This is a very characteristic occurrence of the Keweenaw traps. Between these two groups of igneous rocks it is possible that there may be found sediments of Huronian age since these are known but a few miles to the north in T. 44-6 W. They are, however, all highly metamorphosed and not considered likely to produce iron ore. Nothing is known of the character of the rocks in the southern part of the township but it is probable that both igneous rocks and Huronian sediments occur here.

*Magnetic Observations.*—A general discussion of magnetic observations and their significance is given in Chapter IV. Strong irregular attractions are found in the northwestern part of the township where the trap rocks are exposed, and irregular attraction of a somewhat milder character is found generally over the northern half. Because of the presence of Namakagon Lake the magnetic traverses are very incomplete and the results obtained are not conclusive. That some of the attraction is caused by traps is certain but it is also possible that there may be some magnetic lines indicating the presence of sedimentary rocks. The south half is almost entirely free from attraction.

*Land Classification.*—A general discussion of the principles of land classification employed in this work is given in Chapter V. Lands in the trap area in the northwestern part of the township are classed as D, since there is no prospect for finding iron ore in these rocks. The area upon which gabbro outcrops are found in the northeastern part is also classed as D lands. The presence of the intrusive rocks in sections 1 and 2 and the highly metamorphosed character of the Huronian sediments in T. 44-6 W. makes it appear that the D classification might be applied to nearly the entire northern half of the township, but since there is some doubt the C2 classification is employed. All of the southern half is placed in this class.

*Exploration.*—Exploration is not recommended at present. However, future work in the general area may give information which will make the prospects for the occurrence of ore look more encouraging.

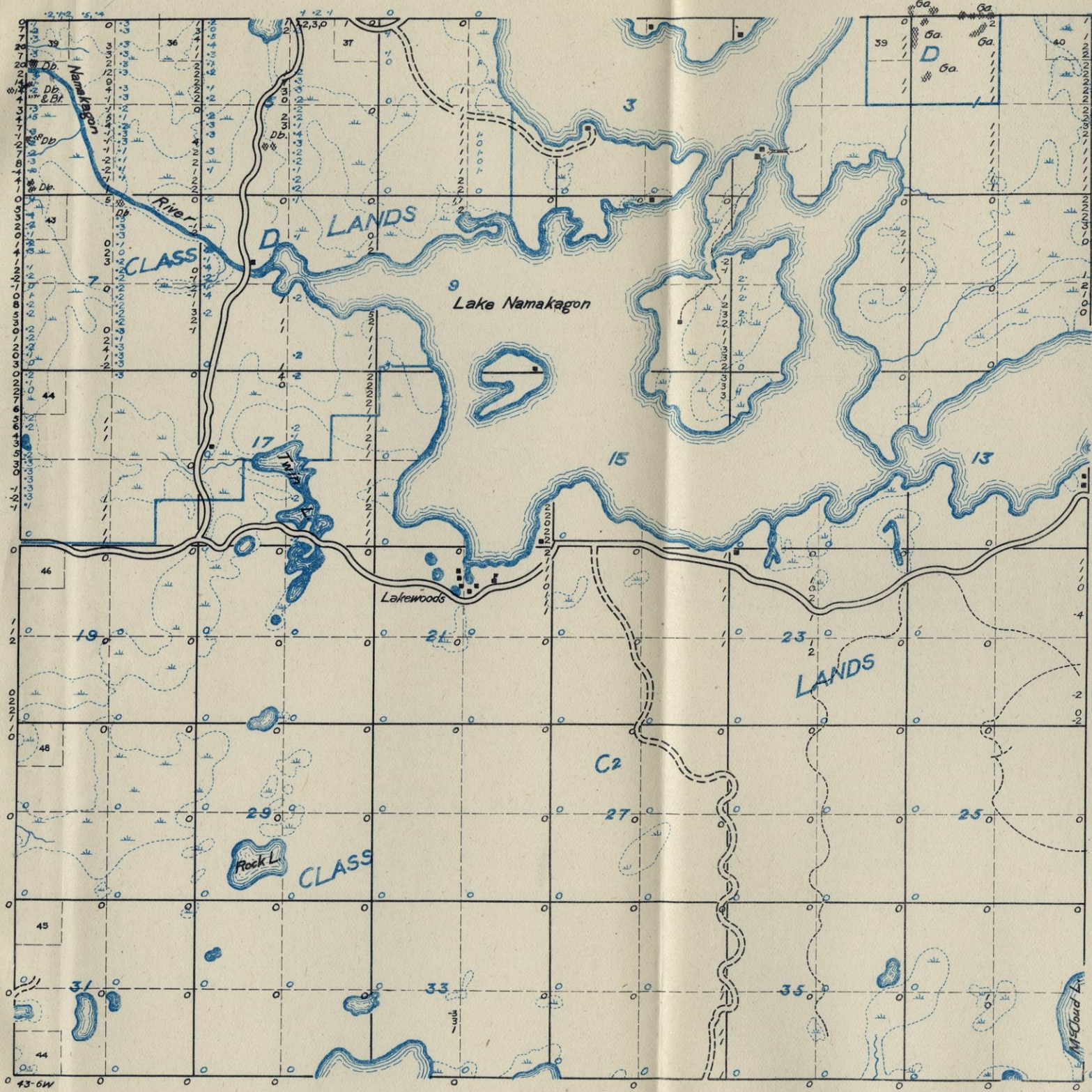

WISCONSIN  
 GEOLOGICAL AND NATURAL HISTORY SURVEY  
 E. A. BIRGE, DIRECTOR

**TOWN 43 N., R. 6W.**

Survey Made in September, 1914

Under the Direction of  
**W. O. HOTCHKISS**, State Geologist  
 AND  
**E. F. BEAN** and **O. W. WHEELWRIGHT**,  
 in charge of Field Parties  
 BY

**J. P. GOLDSBERRY**, Chief of Party  
**G. S. NISHIHARA**, Asst. Geologist

**SYMBOLS AND ABBREVIATIONS.**  
 The symbols and abbreviations used on this map are explained in Chapter II.

**TOWN AND RANGE LINES.**  
 In constructing this map the south line of the township was laid off as a true east west line. The other boundary lines were then laid off with the lengths shown on the Land Survey plat. Some of the maps are therefore incorrect in shape but this is necessary because definite facts are lacking. The acreage of part of the lots in the north and west tier of sections is shown to give a check on the distances in these sections.

**LOCATIONS.**  
 All locations are based on pacing traverses from government land corners. In many cases these were not found and it was necessary to continue the traverse several miles without a check. Locations of certain features may therefore be somewhat wrong. In such cases the feature sought may best be located by its relation to a stream, swamp, lake, or other feature shown on the map.

**PROFILES.**  
 The locations of the profiles are shown on the map by dashed blue lines with black letters at the ends. Railroad profiles were furnished by the companies and show elevations of the ground rather than track in most cases; others are from road surveys by the State Highway Commission: most of them are hand level lines made by this Survey. Wherever possible the elevations above sea level are given. These elevations vary from 1050 to 1770 feet. A local datum plane was necessarily assumed in some cases. These cases are identifiable by the fact that the base line is always numbered 0.

**LAND CLASSIFICATION.**  
 This is shown on the map by the blue letters. It is explained in the following township description and at length in chapter V.

**MAGNETIC DATA.**  
 Dial compass readings are shown in blue figures. Eastward declinations are shown with a dot to the east and westward with a dot to west of the number. Dip needle readings are shown in black. All are positive except those preceded by the negative sign. All readings show deviation of needles from the normal reading of the instrument used. Normal readings are omitted from the map except at each quarter section corner. All abnormal readings are shown.

Traverses were made on lines indicated usually the N-S section and quarter lines. Dip needle readings were taken each 50 paces, dial compass readings each 100 paces when sun permitted.

Magnetic lines are indicated by heavy black lines, solid where definite and dashed where doubtful.

**CAUTION:** Almost any kind of rock may be the cause of magnetic attraction. Do not fail to read the following description of this township, and also chapter IV., in which the magnetic attractions are discussed.

## TOWNSHIP 43 N., RANGE 7 W.

*Surface Features.*—The southern third of this township is very rugged, with elevations as great as 200 feet above the plain to the north. This rugged part is characterized by the presence of very large boulders. In section 21 is a very prominent hill. A distinct ridge extends from the  $\frac{1}{4}$  corner of sections 21 and 22 to the  $\frac{1}{4}$  corner of sections 26 and 25. In the northwestern part of the township is an area of much less rugged topography. The topography of the north central, east central, and northeastern parts of the township is in general level to gently undulating. Near the Namakagon River there is extensive stream dissection. A sandy plain covers the remainder of the township. In sections 5, 6 and 17 this plain is very much pitted and dissected by streams.

Profile A-B shows the plain around Cable, the north-south valley east of Cable, the high level plain to the east of the center of section 17, the steep descent from this plain to the plain bordering the Namakagon river, and the generally level plain in the eastern part of the township.

Most of the roads in this area are good. Nearly all the settlement is confined to the sandy plain. Practically all of the valuable timber has been cut.

*Glacial Drift.*—The southern third of this township is extremely rugged terminal moraine which rises very abruptly from the plain to the north. In the northwest is an area of less rugged terminal moraine. Ground moraine is found in the north central, east central and northeastern parts of the township. Along the Namakagon River and in the western part of this ground moraine area there is a great deal of stream dissection. In the eastern part the ground moraine is very swampy. Pitted outwash veneers the remainder of the township. In sections 5, 8 and 17 and along the Namakagon River this plain is very much dissected. In some places there are well defined terraces along the river.

The glacial deposits are much sand, some silt and numerous boulders in the terminal moraine; sand, silt and boulders in the ground moraine and sand in the outwash.

Rock outcrops occur at several places along the river and in the northeastern part of the township. The elevation of the southern terminal moraine area may be in part due to rock. Local relief indicates, however, that the drift cover averages at least 75 feet in thickness. In the areas of outwash and ground moraine the thickness is probably not great.

*General Geology.*—Rocks of the Keweenawan trap series are exposed at a number of places in the north half of section 1 and along the east line of this section. The rock is mainly a diabase varying in color from reddish brown to nearly black. Some basalt also occurs which is amygdaloidal in places. Of rather common occurrence also is an epidotic rock containing some pyrite. Another group of outcrops of trap rock occurs in the north half of section 21. As in the other localities where the traps are exposed, there is a considerable variety in texture and composition. In the N. E.  $\frac{1}{4}$  of the N. E.  $\frac{1}{4}$  of section 20 the rock varies from a fine dense aphanitic amygdaloidal basalt to a medium coarse gabbro. Six hundred paces down the river the exposure shows a fine basalt and a porphyritic amygdaloidal basalt, as well as a rather fine grained diabase.

T. C. Chamberlin<sup>1</sup> mapped other outcrops in this township which were not visited by the party. The following descriptions are abstracted from his report. "In the northwest of that section (21) on the south side of Namakagon River about 200 feet from its banks an outcrop of granite is observed consisting of flesh-colored feldspar, quartz, and a little biotite. In some portions the granite passes into a gneiss. The bearing of the banded structure is S. 40° E. which crosses at a large angle the trend of the Keweenawan range. About 150 feet west is another exposure of gneiss in which the banded structure is very distinct and often much contorted. Farther down the river is a low ledge of red granite and gneiss. About 1,000 feet below this at the S. E.  $\frac{1}{4}$  of section 16 the river crosses a ledge belonging to the copper-bearing series.

"Near the northwest corner of section 26 the summit of a hill exhibits boulders some of which are of such enormous size as to give the impression that the rock is in place."

He also describes in the S. W.  $\frac{1}{4}$  of the N. E.  $\frac{1}{4}$  of section 26 a small outcrop of gneiss composed of "flesh-colored feldspar, quartz and a large ingredient of biotite with which there is associated some hornblende. The characteristics of these granite masses as well as their position favor the view that they belong to the Laurentian series."

The results of the magnetic work in this township indicates that the Keweenawan traps extend about 1 mile southeast of this granite described in section 21, from which it appears that there is a possibility that the granite is younger than and intrusive into the traps.

<sup>1</sup>T. C. Chamberline, *Geology of Wisconsin*, Vol. 3, pp. 400-401.

Or, if the granite is Laurentian as stated by Chamberlin, it may represent a knob which projected above the general level of the pre-Keweenawan rocks and has been exposed by cutting through the traps at this point. At any rate on the basis of magnetic evidence the trap boundary is placed at the point determined by the magnetic survey. The small area in the southeastern part of the township outside the trap area, as shown approximately by the land classification line, may be underlain by granite or may contain Keweenawan sediments.

*Magnetic Observations.*—A general discussion of magnetic observations and their significance is given in Chapter IV. Irregular attraction is found in all of the township except a few sections in the extreme southeastern part. Its character and the fact that the traps in nearly all areas where exposed are magnetic, justify using this evidence as a basis for drawing the trap boundary.

*Land Classification.*—A general discussion of the principles of land classification employed in this work is given in Chapter V. All lands in the trap area are placed in class D, although the boundary may be somewhat inaccurate. All other lands are placed in class C2.

*Exploration.*—Exploration in this township is not recommended.



# TOWN 43 N., R. 7W.

Survey Made in August, 1914

Under the Direction of

W. O. HOTCHKISS, State Geologist

AND  
E. F. BEAN and O. W. WHEELWRIGHT,  
in charge of Field Parties

BY  
H. D. WAKEFIELD, Chief of Party  
R. S. TARR, Asst. Geologist  
H. N. EIDEMILLER, Asst. Geologist  
J. S. CRANDALL, Asst. Geologist

**SYMBOLS AND ABBREVIATIONS.**  
The symbols and abbreviations used on this map are explained in Chapter II.

**TOWN AND RANGE LINES.**  
In constructing this map the south line of the township was laid off as a true east west line. The other boundary lines were then laid off with the lengths shown on the Land Survey plat. Some of the maps are therefore incorrect in shape but this is necessary because definite facts are lacking. The acreage of part of the lots in the north and west tier of sections is shown to give a check on the distances in these sections.

**LOCATIONS.**  
All locations are based on pacing traverses from government land corners. In many cases these were not found and it was necessary to continue the traverse several miles without a check. Locations of certain features may therefore be somewhat wrong. In such cases the feature sought may best be located by its relation to a stream, swamp, lake, or other feature shown on the map.

**PROFILES.**  
The locations of the profiles are shown on the map by dashed blue lines with black letters at the ends. Railroad profiles were furnished by the companies and show elevations of the ground rather than track in most cases; others are from road surveys by the State Highway Commission: most of them are hand level lines made by this Survey. Wherever possible the elevations above sea level are given. These elevations vary from 1050 to 1770 feet. A local datum plane was necessarily assumed in some cases. These cases are identifiable by the fact that the base line is always numbered 0.

**LAND CLASSIFICATION.**  
This is shown on the map by the blue letters. It is explained in the following township description and at length in chapter V.

**MAGNETIC DATA.**  
Dial compass readings are shown in blue figures. Eastward declinations are shown with a dot to the east and westward with a dot to west of the number. Dip needle readings are shown in black. All are positive except those preceded by the negative sign. All readings show deviation of needles from the normal reading of the instrument used. Normal readings are omitted from the map except at each quarter section corner. All abnormal readings are shown.

Traverses were made on lines indicated—usually the N-S section and quarter lines. Dip needle readings were taken each 50 paces, dial compass readings each 100 paces when sun permitted.

Magnetic lines are indicated by heavy black lines, solid where definite and dashed where doubtful.

**CAUTION:** Almost any kind of rock may be the cause of magnetic attraction. Do not fail to read the following description of this township, and also chapter IV., in which the magnetic attractions are discussed.

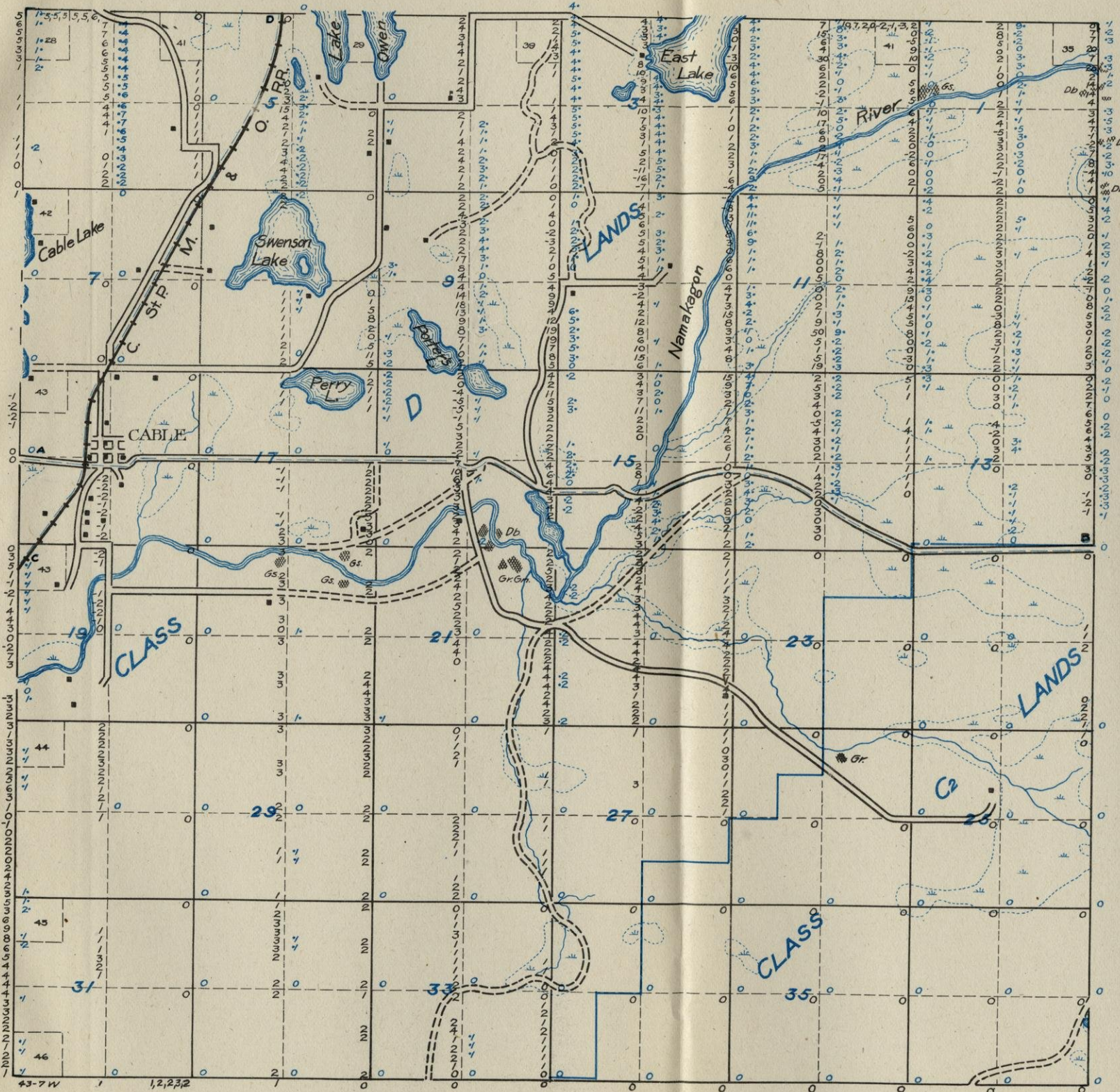

## PROFILES

VERTICAL SCALE: 1 space = 20'  
HORIZONTAL SCALE: same as map

SEA LEVEL DATUM

36 Cor. Sec. 13

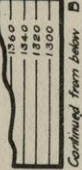

Continued from lobby B

Namakagon River

Namakagon River

W 1/4 Cor. Sec. 10 maha RR Crossing

Continued above

N. Town Line

Keokuk

W. Range Line

A



# INDEX

- Abbreviations, list of, 18.  
Accuracy of dial readings, 97.  
Ackley, Wade, acknowledgments, 8.  
Acknowledgments, 7.  
Adams, work in Cuyuna, 3.  
Age of drift, 24.  
Agglomerate, volcanic, in T. 38, 5 E, 239.  
Agricultural value of land, 138.  
Agriculture, in northern Wis., 137.  
value of glacial drift to, 29.  
Allen, R. C., exploration in Vilas County, 49.  
Alteration of geologic formations, 30.  
American Immigration Co., acknowledgments, 8.  
Amphibole-magnetite rock, and iron formation, 56.  
and magnetic attraction, 56.  
Amphibolite in T. 40, 1 E, 307.  
Analysis of drift, mechanical, 23.  
Angle holes, value of, 158.  
Apparent time, defined, 87.  
Area covered by report, 6, 28.  
drainage of, 58.  
lakes of, 61  
of exposed rocks, 28.  
rivers of, 60.  
surveyed, location of, 2.  
topography of, 58.  
Arpin Hardwood Lumber Co., acknowledgments, 8.  
Atlanta, sandstone at, 33.  
Attraction, see under Magnetic Attraction, 85.  
Authorization of survey, 1.
- Barren areas, elimination of, 145.  
Basalt in T. 43-6 W., 362.  
in T. 43-7 W., 364.  
Barron quartzite, age of, 44.  
areal extent of, 35.  
bedding of, 38.  
cementation of, 40.  
character of, 37.  
color of, 38.  
conditions of folding, 40.
- conglomerate in T. 39-11 W., 37  
41, 300.  
description of, 35.  
dikes in, 44.  
elevation of base of, 42.  
faulting of, 39.  
folding of, 39.  
jointing of, 39.  
metamorphism of, 39.  
outcrops of, 36.  
in T. 34-9 W., 180.  
in T. 34-10 W., 41, 182.  
in T. 35-8 W., 188, 189.  
in T. 35-9 W., 191.  
in T. 35-10 W., 193.  
in T. 36-7 W., 209.  
in T. 36-8 W., 211.  
in T. 36-9 W., 214.  
in T. 36, 10 W., 215.  
in T. 37-8 W., 228, 229.  
in T. 37-9 W., 231.  
in T. 37-11 W., 236.  
in T. 38-8 W., 259.  
in T. 38-9 W., 262.  
in T. 39-6 W., 289.  
in T. 39-7 W., 292.  
in T. 39-8 W., 294.  
in T. 39-9 W., 296.  
in T. 39-11 W., 41, 300.  
in T. 39-12 W., 42, 302.  
in T. 39-13 W., 305.  
in T. 40-6 W., 321.  
in T. 40-7 W., 322.  
in T. 40-8 W., 324.  
pebbles in, T. 40-6 W., 320.  
pipestone phase of, 37.  
relation to Cambrian sandstone, 43.  
relation to drainage, 36.  
relation to formations to east, 44.  
relation to Huronian slates, 50.  
relation to Keweenaw traps, 44.  
relation to other formations, 43.  
structure of, 42.  
thickness of, 43.  
three main phases of, 38.  
topography of, 36.
- Bean, E. F., cost of survey, 7.  
field work, 11.

- Bedding of Barron quartzite, 38.  
 Beverly pre-glacial gorge, 259.  
 Black slate south of Brantwood, 202.  
 Blazing at corners, 26.  
 Brantwood, black slate near, 202.  
 Bronsky, John, acknowledgments, 8.  
 Brooks, T. B., invention of dial compass, 86.  
     on iron ore and magnetic attraction, 84.  
 Bruce, iron formation, west of, 178.  
     iron ore near, 175.  
     pyritic chert, west of, 177.  
     topography south of, 174.  
 Burling, L. D., work of, 2.
- Cambrian, character of, 29.  
 Cambrian sandstone, age of, 35.  
     areal extent of, 32.  
     at Atlanta, 33.  
     boundaries of, 32.  
     character of, 33.  
     description of, 32.  
     distribution of, 32.  
     elevation of base, 34.  
     in Hayward well, 33.  
     outcrops of, 32.  
     in T. 33-8 W., 172.  
     in T. 34-7 W., 175.  
     in T. 34-8 W., 178.  
     in T. 34-9 W., 180.  
     in T. 34-10 W., 182, 183.  
     in T. 35-7 W., 186.  
     in T. 35-8 W., 189.  
     in T. 36-10 W., 215.  
     in T. 37-10 W., 233.  
     in T. 37-11 W., 236.  
     in T. 39-13 W., 305.  
     in T. 40-8 W., 324.  
     in T. 41-9 W., 343.  
     relation to Barron quartzite, 43.  
     relation to other formations, 35.  
     structure of, 34.  
     topography of 32.  
 Carbonate, iron, recognition of, 150.  
 Care of equipment, 19.  
 Catlinite phase of Barron quartzite, 37.  
 Causes of magnetic attraction, 75.  
 Cementation, of Barron quartzite, 40.  
 Character of Cambrian sandstone, 29.  
     of Huronian, 29.  
     of Keweenawan, 29.  
     of Laurentian, 29.  
     of rocks, information from magnetics, 110.  
 Chaurette, George, acknowledgments, 8.  
 Chief of party, directions to, 18.  
     work of, 11, 18.  
 Chloritic schist in T. 40-1 W., 310.  
 Class A, B, C, and D lands, basis for classification, 142, 143, 144.
- Classification, land, see under Land Classification.  
     plan, outline of, 140.  
 Coast and Geodetic Survey, U. S., determinations of magnetic fields, 80.  
 Color of Barron quartzite, 138.  
 Compass, correction table, 94.  
 Compass, dial, see under Dial Compass.  
 Compassman, work of, 9.  
 Component, horizontal, of magnetic field, 125.  
 Components of magnetic force, 108.  
     method of using, 80.  
 Concentration of iron formation, 146.  
 Conglomerate in Barron quartzite, 37, 41, 300.  
     in Flambeau quartzite, 51, 164.  
 Copper in T. 33-6 W., 167, 168.  
 Corners, blazing at, 26.  
 Correction table, compass, 94.  
 Correlation table, 31.  
 Cost of work, 6.  
 Counterweight, effect of upon dip needle, 100.  
     weight of, 101.  
 Crossbedding of Flambeau quartzite, 51.  
 Culture, symbols for, 13.  
 Curves, showing effect of different counterweights, 101.  
 Cuyuna district, description of, 154.  
 Cuyuna, work of Adams in 2.
- Daily variations in declination, 82.  
 Daily variations, table showing maximum and minimum, 82.  
 Declination, daily variations in, 82.  
     definition of, 76.  
     normal, 80.  
     setting of, 25.  
     table of daily variations, 83.  
     U. S. Coast and Geodetic Survey determinations, 80.  
     variations of, and magnetic storm, 83.  
     yearly average of daily variation in, 82.  
 Depth of burial of magnetic formation, determination of, 75.  
 Descriptions of townships, see under township descriptions.  
 Detailed examination before drilling, 156.  
 Detailed magnetic survey, plan of, 156.  
 Determination of direction and intensity of magnetic field, 125.  
 Determinations, dip, sources of error in, 129.  
 Diabase in T. 43-2 W., 356.  
     in T. 43-6 W., 361.  
     in T. 43-7 W., 364.

- Dial compass, description of, 86.  
 needle of, direction assumed by, 125.  
 principles of, 86.  
 sources of error in observations, 90.
- Dial readings, accuracy of, 97.
- Dikes in Barron quartzite, 44, 194, 259.
- Diorite in T. 35-6 W., 184.  
 in T. 36-12 E., 196.  
 in T. 36-10 E., 200.  
 in T. 38-5 E., 239.  
 in T. 38-6 W., 252.  
 in T. 43-2 W., 356.
- Dip circle, description of, 128.  
 standardization of, 131.
- Dip, determination of, from magnetic observations, 75.
- Dip determinations, sources of error in, 129.
- Dip needle, difficulty of keeping in order, 98.  
 effect of counterweight, 100.  
 equilibrium equation, 135.  
 general description, 97.  
 method of holding, 25.  
 method of stopping, 99.  
 method of using, 107.  
 more sensitive than dial, 97.  
 mounting of, 98.  
 new method of holding, 107.  
 positions in crossing magnetic formation, 103.  
 principles of, 98.  
 two forms of, 97.  
 usual method of holding, 107.
- Dip needles, repair of, 106.
- Dip needle observations, sources of error in, 105.
- Dip of rocks, information from magnetics, 112.
- Direction assumed by needle of dial compass, 125.
- Direction of magnetic field, 77.
- Direction of magnetic field, determination of, 125.
- Directions for geological and topographic observations, 22.
- Directions for taking specimens, 22.
- Directions to chief of party, 18.
- District, Cuyuna, description of, 154.
- District, Iron River, description of, 153.
- District, Marquette, description of, 153.
- Dobie, W. L., acknowledgments, 8.
- Drag folds, iron ore in, 149.
- Drainage, effect of glaciation upon, 59.  
 of area, 58.
- Drift, see also glacial drift.  
 iron formation in, 58.  
 mechanical analysis of, 23.  
 observations on age, 24, 25.  
 observations of composition, 23.  
 observations of structure of, 23.  
 observations of weathering, 23.
- Drill cores, necessity for preservation of, 160.
- Drill holes, location of, 159.
- Drilling, detailed examination before, 156.  
 must be at private expense, 145.  
 suggestions for, 159.
- Drill records, interpretation of, 149.
- Drumlins, observations of, 15.
- Dunkle's farm, magnetic field determinations, 133, 134, 135.
- Eidemiller, H. N., acknowledgments, 8.
- Electrification of compass glass, 90.
- Elevation, highest, in area, 59.  
 lowest, in area, 59.
- Elimination of barren areas, 145.
- Equation of time, 26.  
 definition of, 87.  
 method of applying, 88.
- Equilibrium equation for dip needle, 135.
- Equipment, care of, 19.
- Erosion, post-glacial, 48.
- Erratics, notes on, 24.
- Errors in locations, 9.
- Error, sources in the dial compass, 89.  
 sources of in dip determinations, 129.  
 sources of in dip needle observations, 105.
- Eskers observations of, 15.  
 in T. 39-1 E., 274.
- Examination, detailed, before drilling, 156.
- Experiments, laboratory, in magnetics, 112.  
 magnetic, conclusions from, 124.  
 magnetic, generalizations from, 122.
- Exploration and magnetic attraction, 57.
- Exploration, basic principles same in various ranges, 149.
- Exploration, by state, necessity for, 138.
- Exploration for iron ore, definition, 145.  
 geological survey essential to, 146.
- Explorations for iron ore in T. 35-8 W., 190.  
 in T. 35-10 W., 194.  
 in T. 36-9 W., 214.  
 in T. 38-9 W., 262.  
 in T. 41-1 E., 332.  
 in T. 41-1 W., 333.  
 magnetic, on Cuyuna range, 155.  
 percentage of chance of finding ore, 147.  
 profit in, 148.  
 reasons for lack of, 2.  
 study of glacial drift in, 158.  
 underground, methods of, 159.
- Exposures of rock or glacial drift, 22.

- Faulting of Barron quartzite, 39.  
 Field, magnetic, determination of directions and intensity of, 125.  
   magnetic, of the earth, variations in, 81.  
   uniform, definition of, 78.  
   uniform, effect of magnetic formation upon, 78.  
 Field map, directions for, 13.  
 Field observations, 12.  
 Field parties, instructions for, 11.  
 Field work, methods of doing, 9.  
   organization of, 11:  
 Fire arms, 27.  
 Fires, forest, 26.  
 Flambeau quartzite, age of, 52.  
   bedding of, 51.  
   character of, 51.  
   color of, 51.  
   conglomeratic phase of, 51.  
   crossbedding of, 51.  
   jointing in, 51.  
   outcrops of, 50, 164.  
   pebbles in, 164.  
   red slate fragments in, 165.  
   relation to other formations, 52.  
   ripple marks in, 51.  
   structure of, 52, 165.  
   thickness of, 52, 165.  
   topography of, 50.  
 Flambeau Ridge, described, 163, 164.  
   topography north of, 169.  
 Flambeau River, elevation of mouth, 169.  
 Flint, Wm., work of, 2.  
 Florence, magnetic field determinations, 133, 134, 135  
 Folding of Barron quartzite, 39.  
 Forest Fires, 26.  
  
 Gabbro in T. 36-10 E., 200.  
   in T. 43-7 W., 364.  
 Game laws, 27.  
 Garnets in granite gneiss, 275.  
 Garnets in mica schist, 307.  
 General geology, 28.  
 General instructions, 11.  
 General introduction, 1.  
 Geologic formations, 29.  
   alteration of, 30.  
 Geologic information, necessity for in exploration, 149.  
 Geological observations, directions for, 22.  
 Geological survey, essential to exploration, 146.  
 Geologist, work of in magnetic survey, 9.  
 Geologist, work of, in exploration, 149.  
  
 Geology, general, 28.  
   notes on, 13.  
   value of in exploration, 147.  
 Gillis, Fred W., acknowledgments, 8.  
 Glacial deposits, observations of, 14.  
 Glacial drift, analysis of, 62.  
   and character of bed rock, 62.  
   covering ledge, 29.  
   exposures, observations on, 22, 23.  
   notes on, 22.  
   study of, in exploration, 158.  
   tables of analyses, 63-74.  
   value to agriculture, 29.  
 Glacial geology, observations of, 14.  
 Glaciation, effect of, upon drainage, 59.  
   effect upon topography, 47.  
 Gneiss in T. 43-7 W., 364.  
 Gogebic range, description of, 151.  
 Gorge, Beverly pre-glacial, 259.  
 Gorge of Sucker Creek, 230.  
 Granite and syenite in T. 36-11 E., 198.  
 Granite, age of, 54.  
 Granite in T. 33-6 W., 167.  
   in T. 36-6 W., 206.  
   in T. 36-7 W., 209.  
   in T. 37-7 W., 225, 226.  
   in T. 38-4 E., 242.  
   in T. 38-3 E., 244.  
   in T. 38-2 E., 245, 246.  
   in T. 38-5 W., 250.  
   in T. 38-6 W., 253.  
   in T. 38-7 W., 256.  
   in T. 39-3 E., 270.  
   in T. 39-2 E., 272.  
   in T. 39-1 W., 277.  
   in T. 39-2 W., 280.  
   in T. 39-3 W., 282.  
   in T. 39-5 W., 286.  
   in T. 39-6 W., 288.  
   in T. 39-7 W., 292.  
   in T. 40-1 E., 307.  
   in T. 40-1 W., 310.  
   in T. 41-1 W., 332.  
   in T. 41-2 W., 335.  
   in T. 42-2 W., 345.  
   in T. 42-5 W., 347.  
   in T. 42-8 W., 354.  
   in T. 43-2 W., 356.  
   in T. 43-5 W., 359.  
   in T. 43-7 W., 364.  
 Granite gneiss in T. 36-12 E., 196.  
   in T. 37-7 W., 226.  
   in T. 37-8 W., 229.  
   in T. 38-5 W., 250.  
   in T. 38-6 W., 253.  
   in T. 38-7 W., 256.  
   in T. 38-8 W., 259.  
   in T. 39-2 E., 272.  
   in T. 39-1 E., 275.  
   in T. 42-5 W., 347.  
   in T. 43-2 W., 356.  
 Green schist in T. 36-10 E., 200.

- Greenstone in T. 35-8 W., 189.  
 in T. 36-11 E., 198.  
 in T. 36-8 W., 211.  
 in T. 38-6 E., 237.  
 in T. 38-2 E., 246.  
 in T. 39-6 E., 268.
- Ground moraine, observations of, 14.
- Grünerite schist, 54.
- Hand level lines, 25.
- Hayward well, sandstone in, 33, 343.
- Hematite and magnetic attraction, 85.
- Highest elevation, in area, 59.
- Highest elevation in Barron quartzite, 228.
- Hines Lumber Co., acknowledgments, 8.
- Holcombe, schists at, 165.
- Holding dip needle, new method of, 107
- Horizontal component of magnetic field, 125.
- Hornblende schist in T. 36-12 E., 196.  
 in T. 36-11 E., 198.  
 in T. 39-2 E., 272.  
 in T. 39-1 E., 275.  
 in T. 39-5 W., 286.  
 in T. 39-6 W., 288.  
 in T. 40-4 W., 316.  
 in T. 42-5 W., 347.
- Huronian areas, pre-glacial topography of, 46.
- Huronian formations, age of, 50.
- Huronian formations, distribution of, 45.
- Huronian, character of, 29.
- Huronian sediments, character of, 49.  
 evidence of presence, 48.  
 in T. 32-7 W., 164, 165.  
 in T. 33-6 W., 167.  
 in T. 33-7 W., 170.  
 in T. 33-8 W., 172.  
 in T. 34-7 W., 175.  
 in T. 34-8 W., 178.  
 in T. 34-9 W., 181.  
 in T. 35-6 W., 184.  
 in T. 35-7 W., 186.  
 in T. 35-8 W., 189.  
 in T. 35-9 W., 192.  
 in T. 35-10 W., 194.  
 in T. 36-11 E., 198.  
 in T. 36-10 E., 200.  
 in T. 36-3 E., 202.  
 in T. 36-2 E., 204.  
 in T. 36-6 W., 206.  
 in T. 36-7 W., 209.  
 in T. 36-9 W., 214.  
 in T. 37-4 E., 217.  
 in T. 37-3 E., 219.  
 in T. 37-2 E., 222.  
 in T. 37-6 W., 223.  
 in T. 37-7 W., 226.  
 in T. 38-6 E., 237.
- in T. 38-5 E., 240.  
 in T. 38-4 E., 242.  
 in T. 38-3 E., 244.  
 in T. 38-2 E., 246.  
 in T. 38-6 W., 253.  
 in T. 38-7 W., 256.  
 in T. 39-6 E., 268.  
 in T. 39-1 W., 278.  
 in T. 39-2 W., 280.  
 in T. 39-3 W., 282.  
 in T. 39-4 W., 285.  
 in T. 39-5 W., 286.  
 in T. 39-6 W., 289.  
 in T. 39-7 W., 292.  
 in T. 40-1 W., 310.  
 in T. 40-2 W., 312.  
 in T. 40-3 W., 314.  
 in T. 40-4 W., 316.  
 in T. 40-5 W., 318.  
 in T. 40-7 W., 323.  
 in T. 40-8 W., 325.  
 in T. 40-9 W., 326.  
 in T. 41-1 W., 332.  
 in T. 41-6 W., 336.  
 in T. 41-7 W., 339.  
 in T. 41-8 W., 341.  
 in T. 41-9 W., 344.  
 in T. 42-2 W., 345.  
 in T. 42-5 W., 348.  
 in T. 42-6 W., 349.  
 in T. 42-7 W., 351.  
 in T. 42-8 W., 354.  
 in T. 43-4 W., 357.  
 in T. 43-6 W., 362.
- magnetic evidence of, 48.  
 outcrops of, 49.  
 relation to other formations, 49.  
 structure of, 49.
- Huronian slates, relation to Barron quartzite, 50.
- Igneous and metamorphic rocks, 53.  
 distribution of, 53.  
 observations on, 15.  
 relation to Huronian sediments, 54.  
 topography of, 53.
- Inclination, definition of, 76.  
 effect on dip needle of changes in, 102.
- U. S. Coast and geodetic Survey determinations, 80.
- Indian pipestone quarry, in T. 35-10 W., 193.
- Indian quarry, of pipestone, 37.
- Inertia, moment of, magnetometer, 130.
- Instructions for field parties, 11.
- Instructions, general, 11.
- Instruments, magnetic, and their uses, 85.

- Intensity, definition of magnetic, 77.  
 discussion of, 112.  
 effect on dip needle of changes in, 102.  
 field use of in Florence County, 112.  
 variation of, 83.
- Intensity of attraction, measuring, 110.
- Intensity of magnetic field, determination of, 125.
- Introduction, general, 1.
- Iron content of iron formation, 54.
- Iron formations, alteration of, 150.
- Iron formation and amphibole-magnetite rock, 56.
- Iron formation, concentration of, 146.  
 definition of, 55.  
 facts which indicate the presence of, 54.  
 gradation of, 55.  
 importance of oxidized, 150.  
 in drift, 58.  
 indications of, 57.  
 magnetism as evidence of, 28.  
 metamorphism of, 56.  
 occurrence of, 55.  
 original character of, 150.
- Iron formation possibilities in T. 32-7 W., 166.  
 in T. 33-7 W., 170.  
 in T. 33-8 W., 173.  
 in T. 34-7 W., 175.  
 in T. 34-9 W., 181.  
 in T. 35-6 W., 185.  
 in T. 35-7 W., 187.  
 in T. 35-8 W., 190.  
 in T. 36-7 W., 210.  
 in T. 36-8 W., 212.  
 in T. 37-4 E., 217.  
 in T. 37-3 E., 220.  
 in T. 37-2 E., 222.  
 in T. 37-6 W., 223.  
 in T. 38-3 E., 244.  
 in T. 38-2 E., 246.  
 in T. 38-4 W., 249.  
 in T. 38-9 W., 262.  
 in T. 39-1 W., 278.  
 in T. 39-2 W., 281.  
 in T. 39-3 W., 282.  
 in T. 39-4 W., 285.  
 in T. 39-5 W., 287.  
 in T. 39-6 W., 289.  
 in T. 40-1 E., 307.  
 in T. 40-1 W., 310, 311.  
 in T. 40-2 W., 312, 313.  
 in T. 40-3 W., 315.  
 in T. 40-4 W., 317.  
 in T. 40-5 W., 318.  
 in T. 40-6 W., 321.  
 in T. 40-9 W., 326.  
 in T. 41-1 W., 332.  
 in T. 41-2 W., 334.  
 in T. 41-6 W., 337.
- in T. 41-7 W., 339.  
 in T. 41-8 W., 342.  
 in T. 43-4 W., 357.
- Iron formation total area in Lake Superior region, 146.  
 west of Bruce, 178.  
 in T. 34-7 W., 178.
- Iron mining, relation to state welfare, 137.
- Iron ore, chances for finding on magnetic lines, 84.  
 exploration for, definition, 145.  
 explorations for, in T. 35-8 W., 190.  
 explorations for, in T. 35-10 W., 194.  
 explorations for, in T. 36-9 W., 214.  
 near Bruce, 175.  
 occurrence of, as related to geologic structure, 148.  
 per cent of area of iron formation, 147.
- Iron producing formations; extent of, 140.  
 location of, 140.
- Iron River district, description of, 153.
- Irving, R. D., invention of dial compass, 86.  
 work of, 1.
- Island Lake, topography near, 172.
- Jasper, 54.
- Johnson, Henry, acknowledgments, 8.
- Jointing in Barron quartzite, 39.
- Jointing in Flambeau quartzite, 51.
- Kames, observations of, 15.
- Kew-Magnetic Observatory, 83.
- Keweenawan, character of, 29.
- Keweenawan trap, relations to Barron quartzite, 44.
- Keweenawan trap in T. 39-12 W., 302.  
 in T. 39-13 W., 305.  
 in T. 41-8 W., 341.  
 in T. 41-9 W., 344.  
 in T. 42-7 W., 351.  
 in T. 42-8 W., 354.  
 in T. 43-6 W., 362.  
 in T. 43-7 W., 364.
- King, F. H., work of, 61.  
 work of, 2.
- Kneeland-McClurg Lumber Co., acknowledgments, 8.
- Laboratory experiments in magnetics, 112.
- Ladysmith, longitude of, 87.
- Lake deposits, observation of, 15.
- Lakes, description of, 60.  
 table of data on, 61.

- Land classification, 137.  
 Land classification a public function, 137.  
 Land classification, principles of iron, 140.  
   purposes of, 138, 139.  
   outline of, 12.  
 Land classification plan, outline of, 140.  
 Lands to explore in this area, 161.  
 Laurentian, character of, 29.  
 Laws, game, 27.  
 Ledge, depth to, 25.  
   glacial drift covering, 29.  
 Leith, C. K., on exploration, 146.  
 Level bubbles in dip needles, 107.  
 Level lines, 25  
 Loam, definition of, 16.  
 Local standard time defined, 87.  
 Localization of ores, 146.  
 Location of area surveyed, 2.  
 Locations, errors in, 9.  
 Loess, observations of, 15.
- McGilvary, L. P., acknowledgments, 8.  
 Magnetic attraction and hematite, 85.  
 Magnetic attraction and magnetite, 85.  
 Magnetic attraction, and exploration, 57.  
   causes of, 57, 75.  
   characteristics of, 108.  
   local, significance of arrangement of, 84.  
   maximum local, relation to ore, 85.  
   measuring intensity of, 110.  
   method of observation, 14.  
   value of strong, 146.  
 Magnetic attraction as evidence of iron formation, 28.  
 Magnetic attraction in amphibole-magnetite rock, 56.  
 Magnetic attraction in granite, 206.  
 Magnetic attraction in granite in T. 38-7 W., 256.  
   in greenstone, 57, 198.  
   in greenstone, in T. 38-6 E., 237.  
   in T. 38-4 E., 242.  
 Magnetic attraction in hornblende schist, 246.  
   in hornblende schist, in T. 39-2 E., 273.  
   in T. 39-1 E., 275.  
   in T. 40-4 W., 316.  
 Magnetic attraction in Keweenaw trap in T. 39-12 W., 302.  
 Magnetic attraction in metamorphic rocks in T. 40-1 E., 307.  
 Magnetic attraction in other districts, 141.  
 Magnetic attraction in pegmatite, 226.  
 Magnetic attraction in thick and thin formations, 56.
- Magnetic attraction, local, 75.**  
   **locating iron ranges with, 85.**  
   **slight, 85.**  
**Magnetic experiments, conclusions from, 124.**  
   **generalizations from 122.**  
   **laboratory, 112.**  
**Magnetic exploration, on Cuyuna range, 155.**  
**Magnetic field constants, near Florence, 133, 134, 135.**  
**Magnetic field, determination of direction and intensity of, 125.**  
   horizontal component of, 125.  
**Magnetic fields, general discussion of, 75.**  
**Magnetic field of the earth, variations in, 81.**  
**Magnetic formation, position of needle in crossing, 103.**  
**Magnetic indications, most favorable, 57.**  
**Magnetic instruments and their uses, 85.**  
**Magnetic line, meaning of bends in, 157.**  
   relation to ore bodies on Cuyuna range, 156.  
**Magnetic line of good characteristics, 84.**  
**Magnetic moment, 100, 104, 105.**  
**Magnetic needles, determination of relative strengths, 105.**  
**Magnetic observations, determination of depth of burial from, 75.**  
   determination of dip and strike from, 75.  
   general principles of, 75.  
   information obtained from, 110.  
   significance of, 107.  
   special cautions for, 25.  
   value in geological work, 75.  
**Magnetic Observatory, Kew, 83.**  
**Magnetic storms, 83.**  
**Magnetic survey, detailed, plan of, 156.**  
**Magnetite and magnetic attraction, 85.**  
**Magnetometer, description of, use, 126.**  
   standardization of, 129.  
**Main object of survey, 5.**  
**Manner of holding dip, 25.**  
**Map, field, directions for, 13.**  
**Marquette district, description of, 153.**  
**Mean solar time, definition of, 86.**  
**Mechanical analysis of drift, 23.**  
**Meridian, establishing a, 90.**  
**Mesabi range, description of, 150.**  
**Metamorphic rocks, 53.**  
**Metamorphism, of Barron quartzite, 39.**  
   effect on magnetic attraction, 56.  
   of iron formation, 56.  
**Method of applying equation of time, 88.**  
**Methods of doing field work, 9.**  
**Methods of underground exploration, 159.**  
**Mica schist in T. 39-1 W., 277.**  
   in T. 40-1 E., 307.  
   in T. 40-1 W., 310.

- Mineral value, recognition of, 139.  
 Moment, magnetic, 100, 104, 105.  
     turning, of counterweight, 97.  
 Mounting of dip needle, 98.  
 Mud flakes, description of, 38.  
 Needle of dial compass, direction as-  
     sumed by, 125.  
 Needle, dip, principles of, 98.  
 Negative dip needle readings, cause of,  
     103.  
 Nelson, Dr., acknowledgments, 8.  
 Neutral point, definition of, 80.  
     effect upon dip needle, 80.  
 Nishihara, G. S., acknowledgments, 8.  
 North-south line, methods of estab-  
     lishing, 91, 92, 93, 94.  
 Note book, use of, 13.  
 Notes on geology, 13.  
 Nutter, B. J., acknowledgments, 8.  
 Object of survey, 5.  
 Observations, field, 12.  
     magnetic, 75.  
     method of taking, 132.  
 Observation of Polaris, 90.  
 Observations on topography, 24.  
 Olson, Oliver L., acknowledgments, 8.  
 Ore bodies, origin of, 150.  
     size on various ranges, 150-155.  
 Ore, iron, exploration for, definition,  
     145.  
 Ores, localization of, 146.  
 Organization of field work, 11.  
 Outcrops, evidence supplementary to,  
     28.  
     facts sought in detailed examina-  
     tion of rock, 156.  
 Outcrops of Flambeau quartzite, 50.  
 Outline of land classification, 12.  
 Outline of report, ix.  
 Outline for township report, 20.  
 Outwash deposits, observations of, 15.  
 Outwash and lake deposits, observa-  
     tions of, 15.  
 Owen, John, acknowledgments, 8.  
 Oxidized iron formation, importance of,  
     150.  
 Pebbles in Barron quartzite, 37.  
 Pebbles in Barron quartzite in T. 39-  
     11 W., 41.  
 Pebbles in Flambeau quartzite, 51.  
 Pegmatite in T. 36-6 W., 206.  
     in T. 36-7 W., 209.  
     in T. 37-7 W., 226.  
     in T. 38-6 W., 253.  
     in T. 38-7 W., 256.  
     in T. 39-3 E., 270.  
     in T. 39-1 W., 277.  
     in T. 40-1 E., 307.  
     in T. 40-1 W., 310.  
     in T. 43-2 W., 356.  
 Petrology, observations on, 15.  
 Photographs, 26.  
 Pipestone in T. 35-9 W., 191.  
 Pipestone, Indian quarry, in T. 35-  
     10 W., 193.  
 Pipestone phase of Barron quartzite, 37.  
 Pitching troughs, iron ore in, 148.  
 Plan of work, 1913, 7.  
     1914, 7.  
 Planning of work, 19.  
 Polaris, observation of, 90.  
 Porphyry in T. 33-6 W., 167.  
     in T. 34-8 W., 178.  
     in T. 36-7 W., 209.  
 Post-glacial erosion, 48.  
 Pre-Cambrian formations, character of,  
     30.  
 Pre-Cambrian surface, general slope of,  
     34.  
 Pre-glacial topography of area, 46.  
 Previous geologic work, 1.  
 Primary purpose of survey, 12.  
 Profit in exploration, 148.  
 Public, relations to the, 11.  
 Purpose of work, 4.  
 Pyritic chert, west of Bruce, 177.  
 Quartzite, Barron, description of, 35.  
 Quartzite breccia in T. 34-10 W., 183.  
 Quartzite, Flambeau, 50.  
 Quartzite in T. 33-6 W., 167.  
 Quartzite in T. 33-7 W., 170.  
 Quarry, Indian, of pipestone, 37.  
 Range, Gogebic, description of, 151.  
     Marquette, description of, 153.  
     Menominee, description of, 152.  
     Mesabi, description of, 150.  
     Vermilion, description of, 152.  
 Reasons for lack of exploration, 2.  
 Relations to the public, 11.  
 Repair of dip needles, 106.  
 Report, area covered by, 28.  
     outline of, ix.  
 Report, township, 20.  
     weekly, 20.  
 Rice Lake Lumber Co., acknowledg-  
     ments, 8.  
 Rights, mineral, 138.  
 Ripple marks in Flambeau quartzite, 51.  
     in Barron quartzite, 38.  
 River courses, general direction of, 60.  
 Rock exposures, notes on, 22.  
 Rock outcrops, facts sought in detailed  
     examination of, 156.  
 Rocks, area of exposed, 28.  
     igneous, 53.  
     magnetic attraction in, 75.  
     metamorphic, 53.



- Schists, age of, 54.  
 Sedimentary rocks, observations on, 15.  
 Sediments, Huronian, evidence of magnetism regarding, 48.  
 Sherley, Representative, 138.  
 Silica, slump due to leaching of, 150.  
 Slate, black, near Brantwood, 202.  
 Slates, Huronian, relation to Barron quartzite, 50.  
 Slate, tuffaceous, in T. 38-5 E., 239.  
 Slump, due to leaching of silica, 150.  
     as a guide to exploration, 150.  
 Smyth, H. L., on magnetic attraction, 107, 108.  
 Soil, classification of, 16.  
 Soil, clay, definition of, 16.  
 Soil, observations of, 16.  
 Soil, sand, definition of, 16.  
 Sources of error in dip needle observations, 105.  
 Special directions, 18.  
 Specimens, direction for taking, 22.  
 Stain-banded quartzite in T. 37-9 W., 231.  
 Standard time defined, 87.  
 Standardization of dip circle, 131.  
 Standardization of magnetometer, 129.  
 State Highway Commission, acknowledgments, 8.  
 Strike, determination of, from magnetic observations, 75.  
 Strike of rocks, information from magnetism, 110.  
 Structure, of Barron quartzite, 42.  
 Structural geology, necessity for study in exploration, 148.  
 Stupart, R. F., data furnished by, 82.  
 Sucker Creek gorge, 230.  
 Summer resorts, 62.  
 Survey, authorization of, 1.  
     main object of, 5.  
     primary purpose of, 12.  
 Sweet, E. T., thickness of Flambeau quartzite, 52.  
     work of, 1.  
 Swenhardt, J. H., Jr., acknowledgment, 59.  
 Syenite in T. 38-5 E., 240.  
     in T 40-4 W., 316.  
 Symbols for culture, 13.  
 Symbols for topography, 13.  
 Symbols, list of, 17.  
  
 Table, compass correction, 94.  
 Tables of analyses of glacial drift, 63-74.  
 Terminal or recessional moraine, observations of, 15.  
 Terry, Prof. E. M., work by, 125.  
 Thickness, of Barron quartzite, 43.  
 Timber, notes on, 16.  
  
 Time, apparent, defined, 87.  
     correction of, 89.  
     discussion of, 86.  
     equation of, 26.  
     equation of, definition, 87.  
     equation of, method of applying, 88.  
     mean solar, definition of, 86.  
     necessity for accurate, 26.  
     standard, defined, 87.  
 Time correction, 86.  
 Topographic observations, directions for, 22.  
 Topography, of area, 58.  
     effect of glaciation upon, 47.  
     of Flambeau quartzite, 50.  
     observations on, 24.  
     preglacial, of Huronian areas, 46.  
     symbols for, 13.  
 Township descriptions:  
     Township 32- 7 W., 163.  
     33- 6 W., 167.  
     33- 7 W., 169.  
     33- 8 W., 172.  
     34- 7 W., 174.  
     34- 8 W., 177.  
     34- 9 W., 180.  
     34-10 W., 182.  
     35- 6 W., 184.  
     35- 7 W., 186.  
     35- 8 W., 188.  
     35- 9 W., 191.  
     35-10 W., 193.  
     36-12 E., 195.  
     36-11 E., 197.  
     36-10 E., 199.  
     36- 3 E., 202.  
     36- 2 E., 204.  
     36- 6 W., 206.  
     36- 7 W., 208.  
     36- 8 W., 211.  
     36- 9 W., 213.  
     36-10 W., 215.  
     37- 4 E., 217.  
     37- 3 E., 219.  
     37- 2 E., 221.  
     37- 6 W., 223.  
     37- 7 W., 225.  
     37- 8 W., 228.  
     37- 9 W., 230.  
     37-10 W., 233.  
     37-11 W., 235.  
     38- 6 E., 237.  
     38- 5 E., 239.  
     38- 4 E., 241.  
     38- 3 E., 243.  
     38- 2 E., 245.  
     38- 4 W., 248.  
     38- 5 W., 250.  
     38- 6 W., 252.  
     38- 7 W., 255.  
     38- 8 W., 258.

## Township description—con.

- Township 38- 9 W., 261.  
 38-10 W., 264.  
 38-11 W., 266.  
 39- 6 E., 268.  
 39- 3 E., 270.  
 39- 2 E., 272.  
 39- 1 E., 274.  
 39- 1 W., 277.  
 39- 2 W., 280.  
 39- 3 W., 282.  
 39- 4 W., 284.  
 39- 5 W., 286.  
 39- 6 W., 288.  
 39- 7 W., 291.  
 39- 8 W., 293.  
 39- 9 W., 295.  
 39-10 W., 297.  
 39-11 W., 299.  
 39-12 W., 301.  
 39-13 W., 304.  
 40- 1 E., 306.  
 40- 1 W., 309.  
 40- 2 W., 312.  
 40- 3 W., 314.  
 40- 4 W., 316.  
 40- 5 W., 318.  
 40- 6 W., 320.  
 40- 7 W., 322.  
 40- 8 W., 324.  
 40- 9 W., 326.  
 40-10 W., 328.  
 40-11 W., 329.  
 41- 1 W., 331.  
 41- 2 W., 334.  
 41- 6 W., 336.  
 41- 7 W., 338.  
 41- 8 W., 341.  
 41- 9 W., 343.  
 42- 2 W., 345.  
 42- 5 W., 347.  
 42- 6 W., 349.  
 42- 7 W., 351.  
 42- 8 W., 353.  
 43- 2 W., 355.  
 43- 4 W., 357.  
 43- 5 W., 359.  
 43- 6 W., 361.  
 43- 7 W., 363.
- Township report, outline for, 20.  
 True solar day, defined, 87.  
 Turning moment, of counterweight, 97.  
 Ulrich, E. O., fossils referred to, 33.  
 Underground exploration, methods of, 159.  
 Uniform conditions, precautions to secure, 25.  
 Uniform field, definition of, 78.  
 Use of notebook, 13.
- Value, agricultural, of land, 138.  
 mineral, 139.  
 timber, 138.  
 water power, 139.
- Van Hise, C. R., work of, 1.
- Variation, of declination, annual, 83.  
 secular change of declination, 83.  
 daily of declination, table of, 83.
- Variations, daily, in declination table showing maximum and minimum, 82.
- Variations in Magnetic field of the earth, 81.
- Variation, of declination and magnetic storms, 83.
- Vermilion range, description of, 152.
- Watch, method of setting, 89.  
 necessity for accurate, 89.
- Water power possibilities, 138.  
 Water power values, 139.
- Weathering of drift, 23.
- Weekly reports, 20.
- Weidman, Samuel, 44.
- Well data, 25.
- Well records, 13.
- Wheelwright, O. W., cost of survey, 7.  
 fieldwork, 11.
- Work, cost of, 6.  
 plan of, 1913, 7.  
 plan of, 1914, 7.  
 planning of for party, 19.  
 previous geologic, 1.  
 purpose of, 4.
- Work of chief of party, 11, 18.





